

Control Modes

- Torque, velocity

Command Interface

- MACRO
- $\pm 10V$ analog

Communications

- MACRO
- RS-232

Feedback

Incremental

- Digital quad A/B encoder
- Analog sin/cos encoder
- Panasonic Incremental A
- Digital Halls
- Aux. encoder / encoder out

Absolute

- SSI
- EnDat
- Absolute A
- Tamagawa Absolute A
- Panasonic Absolute A Format
- BiSS (B&C)

I/O

- Digital inputs: 10 high speed, 1 motor temp
- Digital outputs: 3 MOSFET, 1 High-speed CMOS

Dimensions: mm [in]

- 196 x 99 x 31 [7.7 x 3.9 x 1.2]

MACRO



Model	I _p	I _c	V _{dc}
AMP-055-18	18	6	20~55
AMP-090-09	9	3	20~90
AMP-090-18	18	6	20~90
AMP-090-36	36	12	20~90
AMP-180-09	9	3	20~180
AMP-180-18	18	6	20~180

DESCRIPTION

Accelnet MACRO is a high-performance, DC powered drive for torque and velocity control of brushless and brush motors via MACRO (Motion And Control Ring Optical). MACRO is a high bandwidth, non-proprietary fiber optic or wired field bus protocol for machine control networks which is based upon 100BASEFX (FDDI) and 100BASETX (Ethernet) hardware technologies. Connections to a MACRO ring are via SC-type fiber optic connectors. MACRO address selection is via two rotary switches for Master and Node addresses.

Drive commissioning is fast and simple using CME 2™ software operating under Windows® and communicating with *Accelnet MACRO* via RS-232.

Feedback from both incremental and absolute encoders is supported. A multi-mode encoder port functions as an input or output depending on the amplifier's basic setup. As an input it takes feedback from a secondary encoder to create a dual-loop position control system or as a master encoder for driving a cam table. As an output, it buffers the digital encoder signals from the motor's digital encoder and eliminate split cables that would be needed to send the signals to both amplifier and control system.

There are 10 high speed digital inputs and 1 digital input for a motor over-temperature switch. Input [IN1] is dedicated to the drive enable function while [IN2~10] are programmable.

Inputs [IN1~10] have 1 μs RC filters for high speed operation and accept inputs from +5~24 Vdc. Each of these inputs has a 10 k Ω resistor that is independently programmable to pull up to +5 Vdc, or to pull down to ground. The Motemp input [IN11] has a fixed 4.99 k Ω pull up resistor to +5 Vdc for compatibility with PTC sensing resistors.

Digital outputs [OUT1~3] are open-collector MOSFET types with 1 k Ω pull up resistors to +5 Vdc. An isolating diode in each enables operation with current-sourcing opto-isolated inputs of PLC's by eliminating leakage currents back into the drive's +5 Vdc supply when the outputs are off. [OUT4] is a high-speed CMOS output.

Drive power is transformer-isolated DC from regulated or unregulated power supplies. An HV_AUX input is provided for "keep-alive" operation permitting the drive power stage to be completely powered down without losing position information, or communications with the control system.

In addition to the MACRO interface, torque and velocity control is also supported via an analog input with a ± 10 Vdc range.

GENERAL SPECIFICATIONS

Test conditions: Load = Wye connected load: 2 mH + 2 Ω line-line. Ambient temperature = 25°C, +HV = HV_{max}

MODEL	AMP-055-18	AMP-090-09	AMP-090-18	AMP-090-36	AMP-180-09	AMP-180-18	
OUTPUT POWER							
Peak Current	18 (12.7)	9 (6.9)	18 (12.7)	36 (26.5)	9 (6.4)	18 (12.7)	Adc (Arms, sinusoidal), ±5%
Peak time	1	1	1	1	1	1	Sec
Continuous current	6 (4.2)	3 (2.1)	6 (4.2)	12 (8.5)	3 (2.1)	6 (4.2)	Adc (Arms, sinusoidal)
Output resistance	0.075	0.075	0.075	0.075	0.075	0.075	Rout (Ω)
Maximum Output Voltage	Vout = HV*0.97 - Rout*Iout						
INPUT POWER							
HVmin~HVmax	20 - 55	20 - 90	20 - 90	20 - 90	20 - 180	20 - 180	+Vdc, Transformer-isolated
Ipeak	20	10	20	40	10	20	Adc (1 sec) peak
Icont	5.47	2.74	5.47	10.64	2.74	5.47	Adc continuous
HVAUX	+20 to +HV Vdc @ 500 mAdc maximum, 2.5 W						
PWM OUTPUTS							
Type	3-phase MOSFET inverter, 15 kHz center-weighted PWM, space-vector modulation						
PWM ripple frequency	30 kHz						
COMMAND INPUTS							
Torque, velocity control	MACRO digital interface ±10 Vdc analog input Duplex SC optical fiber receptacle						
Connectors	62.5 micron Multi-Mode Glass Fiber per ISO/IEC 9314-3 & ANSI X3.166-1990						
Fiber medium	Commonly referred to as "62.5/125 multi-mode" glass fiber cable						
Wavelength	1300 nm						
Data Format	MACRO						
Address Selection	Dual 16-position rotary switches for Master and Node addresses						
Address range	0x0 to 0xF hex (0~15 decimal) for Master & Node						
Analog	±10 Vdc, 12 bit resolution, differential, 5 kΩ input impedance, non-isolated						
DIGITAL CONTROL							
Current Control Loop	100% digital loop control						
Sampling rate (time)	15 kHz (66.7 μs) for current loop, 3 kHz (333 μs) for velocity loop						
Commutation	Sinusoidal, field-oriented control for brushless motors						
Modulation	Center-weighted PWM with space-vector modulation						
Bandwidths	Current loop: 2.5 kHz typical, bandwidth will vary with tuning & load inductance						
HV Compensation	Changes in bus voltage do not affect bandwidth						
Minimum load inductance	200 μH line-line						
DIGITAL INPUTS							
Number	10 HS (High-Speed), 1 GP (Motemp), non-isolated						
[IN1~10]	HS: 1 μs RC filtered, CMOS, +5~24 Vdc, programmable pull up/down (+5V/0V) on each input V _{I+} = 3.15 Vdc max, V _{I-} = 1.13 Vdc min, V _I = 0.6~1.40 Vdc						
[IN11]	GP: Motor over-temperature switch, 33 μs RC filter, 4.99 kΩ fixed pull up to +5 Vdc Active level of all inputs is programmable						
DIGITAL OUTPUTS							
Number	3 GP (General Purpose), 1 HS (High-Speed), non-isolated						
[OUT1]	GP: N-channel MOSFET, 1 Adc, +30 Vdc, with 1 kΩ pull-up resistor to +5 Vdc						
[OUT2,3]	GP: N-channel MOSFET, 100 mAdc, +30 Vdc, with 1 kΩ pull-up resistor to +5 Vdc						
[OUT1,2,3]	Diode in series with pull up resistor prevents current flow into +5 Vdc supply when outputs are off and pulled up to voltages >5 Vdc						
[OUT4]	HS: CMOS UHS buffer, ±20 mA source/sink, +5 Vdc max						
MULTI-MODE ENCODER PORT							
As Secondary Encoder Input	Digital quadrature encoder (A, /A, B, /B, X, /X) 20M counts/sec, post-quadrature (5M lines/sec), MAX3096 line receiver						
As Buffered Encoder Output	Buffered signals from digital quad A/B/X primary encoder. 20M counts/sec, post-quadrature (5M lines/sec) A, /A, B, /B, X, /X, signals from MAX3042 differential line driver						
Secondary encoder power	+5 Vdc ±2% @ 400 mAdc max, current limited to 750 mAdc @ +1 Vdc if output overloaded (J4-22)						
FEEDBACK							
<i>Incremental:</i>							
Digital Incremental Encoder	Quadrature signals, (A, /A, B, /B, X, /X), differential (X, /X Index signals not required) 5 MHz maximum line frequency (20 M counts/sec) 26LS32 differential line receiver with 121 Ω terminating resistor between complementary inputs						
Analog Incremental Encoder	Sin/cos format (sin+, sin-, cos+, cos-), differential, 1 Vpeak-peak, ServoTube motor compatible						
<i>Absolute:</i>							
SSI	Clock (X, /X), Data (S, /S) signals, 4-wire, clock output from AEP, data returned from encoder						
EnDAT	Clock (X, /X), Data (S, /S), sin/cos (sin+, sin-, cos+, cos-) signals						
Absolute A, Tamagawa Absolute A	Panasonic Absolute A Format SD+, SD- (S, /S) signals, 2.5 or 4 MHz, 2-wire half-duplex communication position feedback: 13-bit resolution per rev, 16 bit revolution counter (29 bit absolute position data) status data for encoder operating conditions and errors						
BiSS (B&C)	MA+, MA- (X, /X), SL+, SL- (S, /S) signals, 4-wire, clock output from AEP, data returned from encoder						
Encoder power	+5 Vdc ±2% @ 400 mAdc max, current limited to 750 mAdc @ +1 Vdc if output overloaded (J3-3)						

RS-232 PORT

Signals	RxD, TxD, Gnd in 6-position, 4-contact RJ-11 style modular connector.
Mode	Full-duplex, DTE serial port for drive setup and control, 9,600 to 115,200 Baud
Protocol	ASCII or binary format

MOTOR CONNECTIONS

Phase U, V, W	PWM outputs to 3-phase ungrounded Wye or delta connected brushless motors, or DC brush motors
Hall U, V, W	Digital Hall signals, single-ended
Digital Incremental Encoder	Quadrature signals, (A, /A, B, /B, X, /X), differential (X, /X Index signals not required) 5 MHz maximum line frequency (20 M counts/sec) 26LS32 differential line receiver with 121 Ω terminating resistor between complementary inputs
Analog Incremental Encoder	Sin/cos format (sin+, sin-, cos+, cos-), differential, 1 V _{peak-peak} X or S input may be firmware configured to latch position or time
SSI	Serial data and clock signals (DATA, /DATA, CLK, /CLK), differential
EnDat 2.1, 2.2	Serial data and clock signals (DATA, /DATA, CLK, /CLK), differential; optionally sin/cos signals
EnDat 2.1,2.2	Serial data and clock signals (DATA, /DATA, CLK, /CLK), differential
Absolute A, Tamagawa Absolute A, Panasonic Absolute A Format	SD+, SD- (S, /S) signals MA+, MA-, SL+, SL-
BiSS (B&C)	+5 Vdc $\pm 2\%$ @ 400 mAdc max, current limited to 750 mAdc @ +1 Vdc if output overloaded
Hall & encoder power (J3-3)	Motor overtemperature switch input. Active level programmable, 4.99 k Ω pull-up to +5 Vdc
Motemp [IN11]	Programmable to disable amplifier when motor over-temperature condition occurs
Brake	[OUT1] programmable for motor brake function

STATUS INDICATORS

Amp Status	Bicolor LED, drive status indicated by color, and blinking or non-blinking condition
MACRO Status	Bicolor LED, status of MACRO bus indicated by color and blink codes to MACRO Indicator Specification V0.91

PROTECTIONS

HV Overvoltage	+HV > HV _{max}	Drive outputs turn off until +HV < HV _{max} (See Input Power for HV _{max})
HV Undervoltage	+HV < +20 Vdc	Drive outputs turn off until +HV > +20 Vdc
Drive over temperature	Heat plate > 70°C.	Drive outputs turn off
Short circuits	Output to output, output to ground, internal PWM bridge faults	
I ² T Current limiting	Programmable: continuous current, peak current, peak time	
Motor over temperature	Digital inputs programmable to detect motor temperature switch	
Feedback Loss	Inadequate analog encoder amplitude or missing incremental encoder signals	

MECHANICAL &

Size	7.73 in (196.3 mm) X 3.90 in (99.1 mm) X 1.17 in (29.7 mm)
Weight	1.0 lb (0.45 kg)
Ambient temperature	0 to +45°C operating, -40 to +85°C storage
Humidity	0 to 95%, non-condensing
Vibration	2 g peak, 10~500 Hz (sine), IEC60068-2-6
Shock	10 g, 10 ms, half-sine pulse, IEC60068-2-27
Contaminants	Pollution degree 2
Environment	IEC68-2: 1990
Cooling	Heat sink and/or forced air cooling required for continuous power output

AGENCY STANDARDS CONFORMANCE

EN 55011 : 1998	CISPR 11 (1997) Edition 2/Amendment 2: Limits and Methods of Measurement of Radio Disturbance Characteristics of Industrial, Scientific, and Medical (ISM) Radio Frequency Equipment
EN 61000-6-1 : 2001	Electromagnetic Compatibility Generic Immunity Requirements Following the provisions of EC Directive 89/336/EEC:
EN 61010-1 2 nd Ed.: 2001	Safety Requirements for Electrical Equipment for Measurement, Control, and Laboratory use Following the provisions of EC Directive 2006/95/EC
UL 508C 3 rd Ed.: 2002	UL Standard for Safety for Power Conversion Equipment

MACRO COMMUNICATIONS

MACRO (Motion And Control Ring Optical) is a non-proprietary communications network that uses optical fibre or copper cabling and supports bit-rates up to 125 Mb/sec. The Accelnet MACRO (AMP) uses the optical fibre interface and operates typically as a torque drive. Velocity drive mode is also supported.

More information on MACRO can be found on the organization web-site: <http://www.macro.org/index.html>

MACRO CONNECTIONS

Dual SC sockets accept standard optical fiber. The IN port connects to a master, or to the OUT port of a device that is 'upstream', between the Accelnet and the master. The OUT port connects to 'downstream' nodes. If Accelnet is the last node on a network, only the IN port is used. No terminator is required on the OUT port.

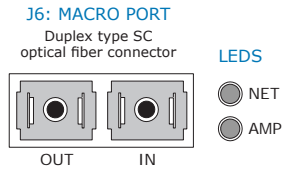

MACRO STATUS LED (NET)

A bi-color LED gives the state of the MACRO interface by changing color, and either blinking or remaining solid. The possible color and blink combinations are:

- Off* = MACRO network has not been detected
- Green/Blinking* = MACRO network detected and has disabled drive
- Green* = MACRO network detected and is trying to enable drive
This condition can occur while the AMP LED shows any of its' possible color combinations.
This LED must be green in order for the AMP LED to become green
- Red/Solid* = MACRO network errors have been detected

DRIVE STATUS LED (AMP)

A bi-color LED gives the state of the Accelnet drive. Colors do not alternate, and can be solid ON or blinking:

- Green/Slow-Blinking* = Drive OK but NOT-enabled. Will run when enabled.
If drive is hardware-enabled but disabled by MACRO then both NET and AMP LED's will be blinking
- Green/Fast-Blinking* = Positive or Negative limit switch active.
Drive will only move in direction not inhibited by limit switch.
NET LED can be Green in this state
- Green* = Drive OK, hardware-enabled, and MACRO-enabled.
Will drive motor in response to command inputs or MACRO commands.
- Red/Solid* = Transient fault condition. Drive will resume operation when fault is removed.
- Red/Blinking* = Latching fault. Operation will not resume until drive is Reset.

MACRO ADDRESS

A PMAC card can hold up to four MACRO IC's numbered 0,1,2,3 each of which is a master on a MACRO ring. Switch S1 is set to select the master IC to which the Accelnet will be linked. As a MACRO station or node the Accelnet has eight available addresses as a motion control device. These are 0,1,4,5,8,9,12, & 13. Addresses 2,3,6,7,10, & 11 are for I/O stations and addresses 14 & 15 are reserved. The table shows the available selections for S1 & S2. Boxes greyed-out are invalid selections and have no function. The switch positions are numbered in hexadecimal. The chart shows these positions with the master and slave addresses shown in decimal.

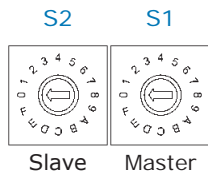

MACRO Address Switches

Switch	S2	S1
Address	SLAVE	MASTER
HEX	DEC	
0	0	0
1	1	1
2		2
3		3
4	4	
5	5	
6		
7		
8	8	
9	9	
A		
B		
C	10	
D	11	
E		
F		

CME 2™ SOFTWARE

Amplifier setup is fast and easy using CME 2™ software. All of the operations needed to configure the amplifier are accessible through this powerful and intuitive program. Auto-phasing of brushless motor Hall sensors and phase wires eliminates “wire and try”. Connections are made once and CME 2™ does the rest thereafter. Encoder wire swapping to establish the direction of positive motion is eliminated. Motor data can be saved as .CCM files. Amplifier data is saved as .CCX files that contain all amplifier settings plus motor data. This eases system management as files can be cross-referenced to amplifiers. Once an amplifier configuration has been completed systems can be replicated easily with the same setup and performance.

RS-232 COMMUNICATIONS

Accelnet EtherCAT is configured via a three-wire, full-duplex DTE RS-232 port that operates from 9600 to 115,200 Baud. CME 2™ provides a graphic user interface (GUI) to set up all of Accelnet EtherCAT features via a computer serial port. Connections to the Accelnet EtherCAT RS-232 port are through J6, an RJ-11 style connector. Signal format is full-duplex, 3-wire, DTE using RxD, TxD, and Gnd. The Accelnet EtherCAT Serial Cable Kit (SER-CK) contains a modular cable, and an adapter that connects to a 9-pin, Sub-D serial port connector (COM1, COM2, etc.) on PC’s and compatibles.

J5: RS-232 PORT

RJ-11 receptacle, 6 position, 4 contact

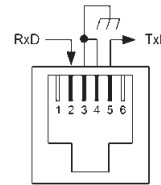

PIN	SIGNAL
2	RxD
3,4	Gnd
5	TxD

CME2 -> Tools -> Communications Wizard



ANALOG INPUT

The differential configuration of the analog input has a ±10 Vdc range and is useful for reading sensors or other voltage sources while rejecting noise on the signal ground that can occur due to power supply currents flowing in the wires to the drive. Shielded, twisted-pair wires are the best choice for connecting the input to the voltage source. One of the input terminals connects to the voltage source and the other should connect to signal ground at the voltage source. The effective range of the input can be scaled via a digital input, too. When the input is asserted the value of the commanded current or velocity command is divided by 8.

ANALOG INPUT [AI+/-]

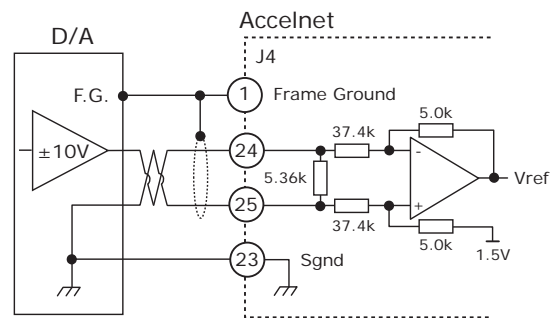

CME2 -> Basic Setup -> Operating Mode Options



DIGITAL INPUTS

These are high-speed (HS) non-isolated types with pull-up resistors to +5 Vdc and 1 μ s RC filters when driven by active sources. The active level is programmable on each input. Input [IN1] is dedicated to the drive enable function. The remaining inputs [IN2~IN10] have programmable functions. Input [IN11] is set up for the motor overtemperature function and connects to the feedback connector J3. If not used as the Motemp input it can be programmed for other functions. All of the inputs can operate from +5 to +24 Vdc sources.

HS Inputs [IN1~10]

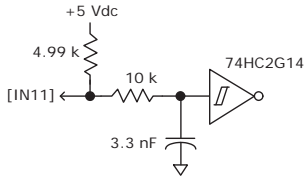

MOTEMP [IN11]

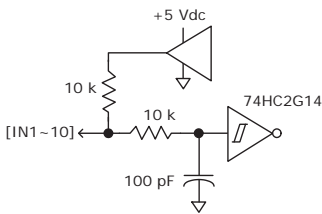

CME2 -> Input / Output

Input	Configuration	Debounce time
[IN1]	Pull up +5V / Pull down [IN1] Amp Enable-LO Enables With Clear Faults	0 ms
[IN2]	Pull up +5V / Pull down [IN2] Not Configured	0 ms
[IN3]	Pull up +5V / Pull down [IN3] Not Configured	0 ms
[IN4]	Pull up +5V / Pull down [IN4] Not Configured	0 ms
[IN5]	Pull up +5V / Pull down [IN5] Not Configured	0 ms
[IN6]	Pull up +5V / Pull down [IN6] Not Configured	0 ms
[IN7]	Pull up +5V / Pull down [IN7] Not Configured	0 ms
[IN8]	Pull up +5V / Pull down [IN8] Not Configured	0 ms
[IN9]	Pull up +5V / Pull down [IN9] Not Configured	0 ms
[IN10]	Pull up +5V / Pull down [IN10] Not Configured	0 ms
[IN11]	Pull up +5V / Pull down [IN11] Not Configured	0 ms

DIGITAL OUTPUTS

The table below shows the features of the four digital outputs. Programmable functions include:

- Drive fault indicator
- Motor brake
- PWM sync
- Program control
- Custom event

If inductive loads (brake, relays) are used, external snubber diodes are required to limit the flyback voltage to 30 Vdc.

GP [OUT1~3]

100 mAdc, 30 Vdc max

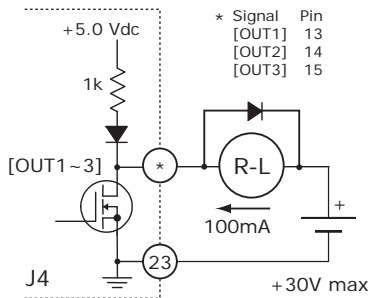

HS [OUT4]

± 20 mAdc 5 Vdc max

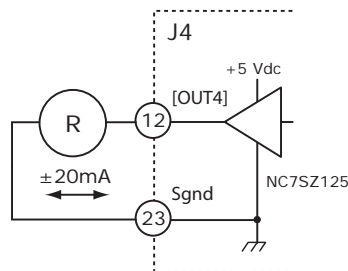

CME2 -> Input / Output

Output	Configuration
[OUT 1]	Brake-Active High
[OUT 2]	Custom Event
[OUT 3]	Not Configured
[OUT 4]	Not Configured

MOTOR CONNECTIONS

Motor connections consist of: phases, Halls, encoder, and thermal sensor. The phase connections carry the drive output currents that drive the motor to produce motion. The Hall signals are three digital signals that give absolute position feedback within an electrical commutation cycle. The encoder signals give incremental position feedback and are used for sinusoidal commutation. A thermal sensor that indicates motor overtemperature is used to shut down the drive to protect the motor.

QUAD A/B ENCODER WITH FAULT PROTECTION

Encoders with differential line-driver outputs provide incremental position feedback via the A/B signals and the optional index signal (X) gives a once per revolution position mark. The MAX3097 receiver has differential inputs with fault protections for the following conditions:

Short-circuits line-line: This produces a near-zero voltage between A & /A which is below the differential fault threshold.

Open-circuit condition: The 121Ω terminator resistor will pull the inputs together if either side (or both) is open. This will produce the same fault condition as a short-circuit across the inputs.

Low differential voltage detection: This is possible with very long cable runs and a fault will occur if the differential input voltage is < 200mV.

±15kV ESD protection: The 3097E has protection against high-voltage discharges using the Human Body Model.

Extended common-mode range: A fault occurs if the input common-mode voltage is outside of the range of -10V to +13.2V

If encoder fault detection is selected (CME2 main page, Configure Faults block, Feedback Error) and an encoder with no index is used, then the X and /X inputs must be wired as shown below to prevent the unused index input from generating an error for *low differential voltage detection*.

A/B/X CONNECTIONS

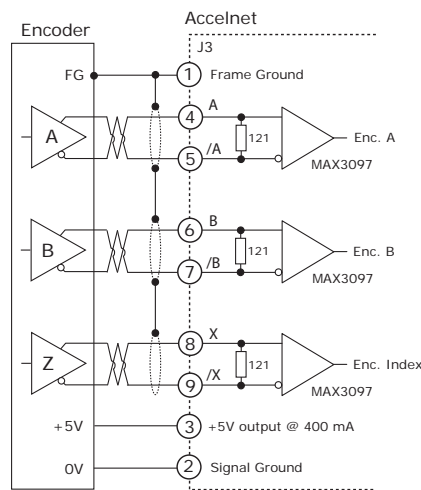

A/B CONNECTIONS (NO INDEX)

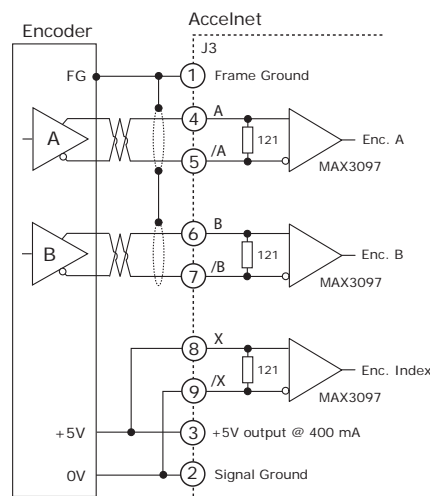

CME2 -> Motor/Feedback -> Feedback

Motor Encoder:

ANALOG SIN/COS INCREMENTAL ENCODER

The sin/cos inputs are differential with 121 Ω terminating resistors and accept 1 Vp-p signals in the format used by incremental encoders with analog outputs, or with [ServoTube](#) motors.

CME2 -> Motor/Feedback -> Feedback

Motor Encoder:

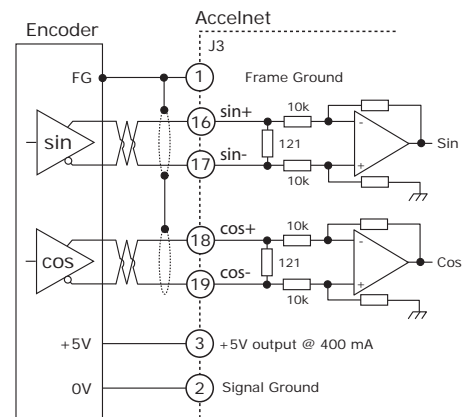

MOTOR CONNECTIONS (CONTINUED)

MULTI-MODE ENCODER PORT

This port consists of three differential input/output channels with functions programmable.

For dual-loop position-mode operation that employs a primary encoder on the motor, and a secondary encoder on the load, the port works as an input receiving the secondary encoder's quad A/B/X signals.

For stand-alone operation with an external motion controller, the signals from the digital encoder on the motor are buffered and made available at the control signal connector for transmission to the controller. This eliminates split-wired motor cables with dual connectors that take the encoder signals to both amplifier and controller.

INPUT FROM A SECONDARY ENCODER

A quad A/B/X digital encoder on the load provides feedback on the load position for a dual position loop configuration.

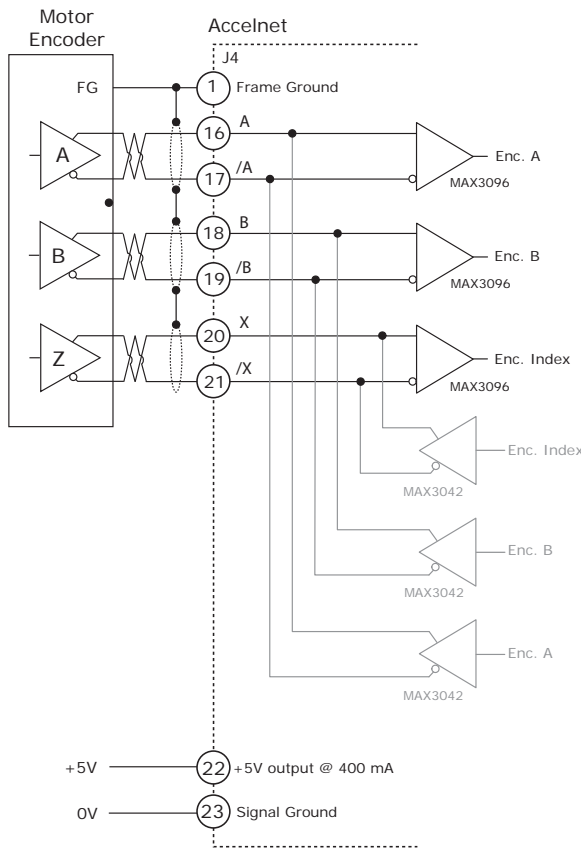

BUFFERED OUTPUTS FROM THE MOTOR ENCODER

Signals from a quad A/B/X digital encoder on the motor are buffered for transmission to an external motion controller.

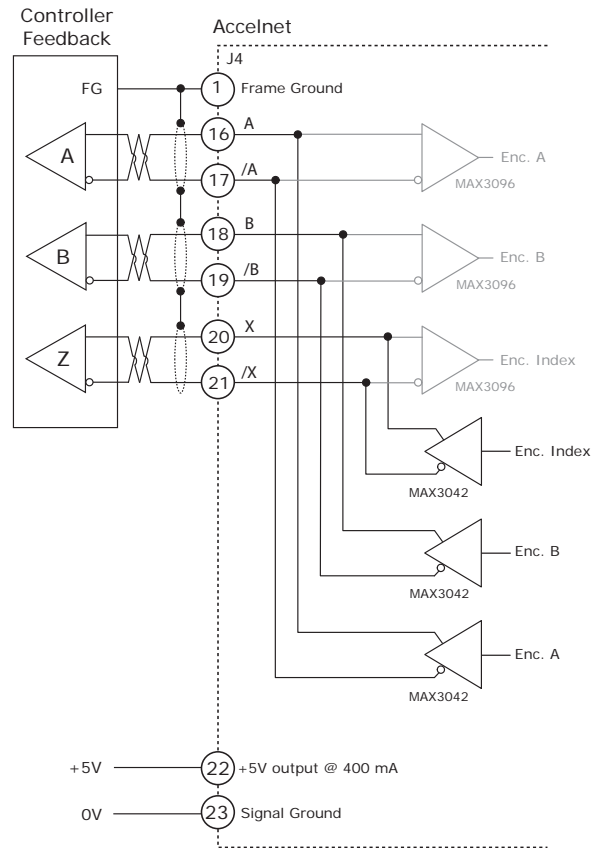

EMULATED QUAD A/B OUTPUTS FROM THE MOTOR ENCODER

When using sin/cos analog incremental encoders, the number of bits of interpolation per electrical cycle will determine the resolution of the emulated outputs.

For absolute encoders, the quad A/B resolution will depend on the number of bits in the absolute encoder.

CME2 -> Basic setup -> Feedback Options

Position Encoder:

CME2 -> Basic setup -> Miscellaneous Options

Multi-mode Port:

MOTOR CONNECTIONS (CONTINUED)

SSI ABSOLUTE ENCODER

The SSI (Synchronous Serial Interface) is an interface used to connect an absolute position encoder to a motion controller or control system. The Accelnet drive provides a train of clock signals in differential format (Clk, /Clk) to the encoder which initiates the transmission of the position data on the subsequent clock pulses. The polling of the encoder data occurs at the current loop frequency (15 kHz). The number of encoder data bits and counts per motor revolution are programmable. Data from the encoder in differential format (Dat, /Dat) MSB first. When the LSB goes high and a dwell time has elapsed, data is ready to be read again.

CME2 -> Motor/Feedback -> Feedback

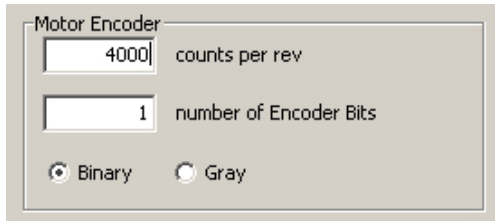

ENDAT ABSOLUTE ENCODER

The EnDat interface is a Heidenhain interface that is similar to SSI in the use of clock and data signals for synchronous digital, bidirectional data transfer. It also supports analog sin/cos channels from the same encoder. The number of position data bits is programmable. Use of sin/cos incremental signals is optional in the EnDat specification.

CME2 -> Motor/Feedback -> Feedback

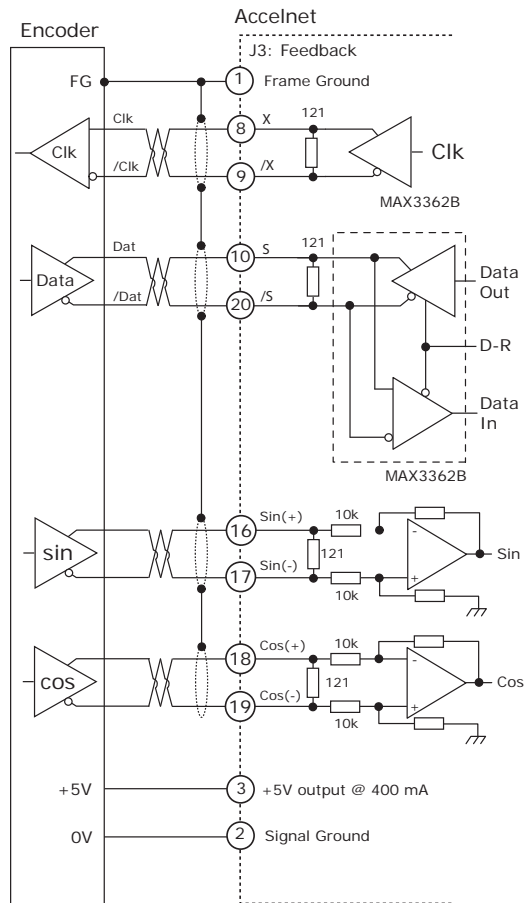
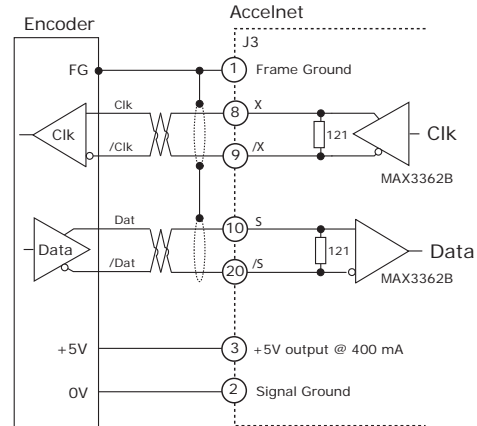
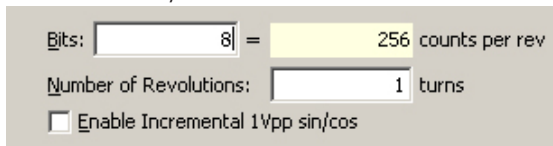

MOTOR CONNECTIONS (CONTINUED)

**ABSOLUTE-A
TAMAGAWA ABSOLUTE A
PANASONIC ABSOLUTE A FORMAT
ENCODERS**

The Absolute A interface uses 2-wire, half-duplex communication. Encoders of this type are used on motors manufactured by Tamagawa-Seki, Panasonic, and Sanyo Denki.

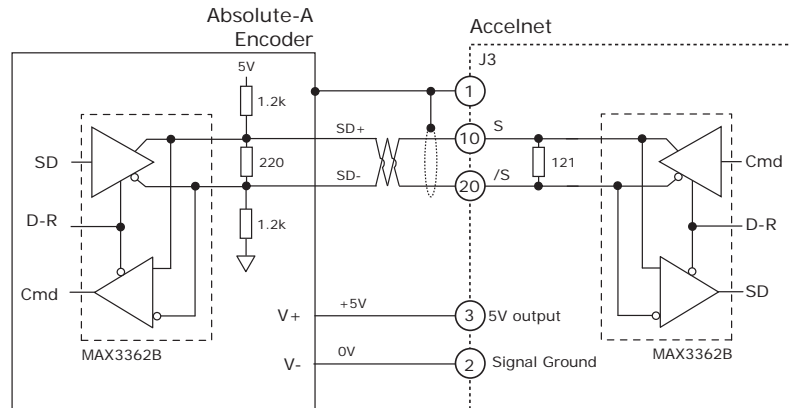

CME2 -> Motor/Feedback -> Feedback

Bits: = counts per rev

Number of Revolutions: turns

Number of Counts Per Rev Bits to Ignore:

Bit Rate:

2.5 MB/s 4 MB/s

BiSS ABSOLUTE ENCODER

BiSS is an - Open Source - digital interface for sensors and actuators. BiSS refers to principles of well known industrial standards for Serial Synchronous Interfaces like SSI, AS-Interface® and Interbus® with additional options. The Accelnet supports the BiSS C (unidirectional) protocol.

- Serial Synchronous Data Communication
- Cyclic at high speed
- 2 unidirectional lines Clock and Data
- Line delay compensation for high speed data transfer
- Request for data generation at slaves
- Safety capable: CRC, Errors, Warnings
- Bus capability for multiple slaves & devices in a chain.

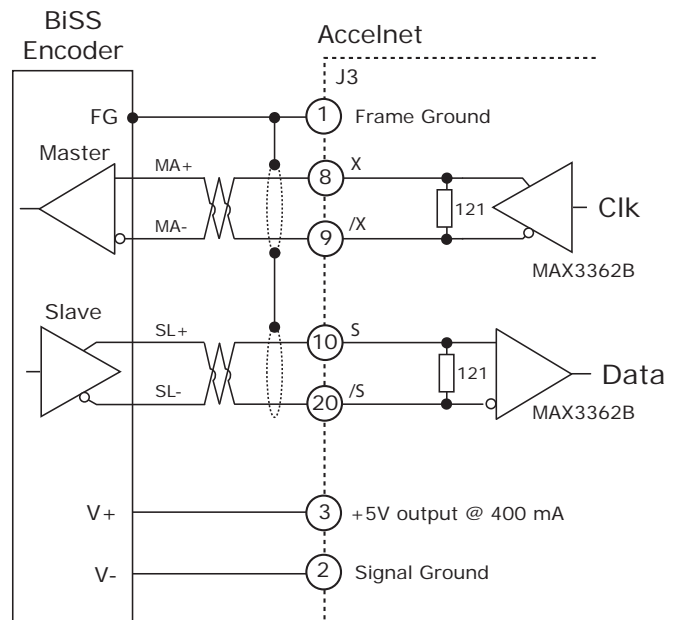

CME2 -> Motor/Feedback -> Feedback

Bits: = counts per rev

Number of Revolutions: turns

Number of Alignment Bits:

BiSS B BiSS C

MOTOR CONNECTIONS (CONTINUED)

DIGITAL HALL SIGNALS

Hall signals are single-ended signals that provide absolute feedback within one electrical cycle of the motor. There are three of them (U, V, & W) and they may be sourced by magnetic sensors in the motor, or by encoders that have Hall tracks as part of the encoder disc. They typically operate at much lower frequencies than the motor encoder signals, and are used for commutation-initialization after startup, and for checking the motor phasing after the amplifier has switched to sinusoidal commutation.

CME2 -> Basic Setup -> Feedback Options

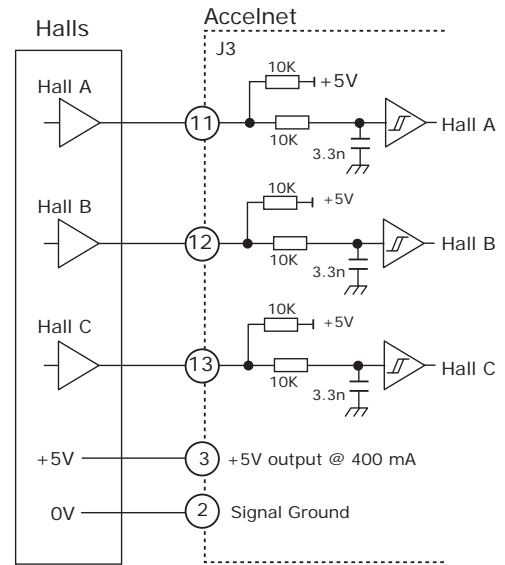
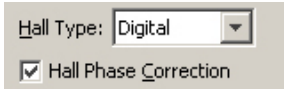

PHASE CONNECTIONS

The drive output is a three-phase PWM inverter that converts the DC bus voltage (+HV) into three sinusoidal voltage waveforms that drive the motor phase-coils. Cable should be sized for the continuous current rating of the drive. Motor cabling should use twisted, shielded conductors for CE compliance, and to minimize PWM noise coupling into other circuits. The motor cable shield should connect to motor frame and the drive HV ground terminal (J2-1) for best results. When driving a DC motor, the W output is unused and the motor connects between the U & V outputs.

CME2 -> Basic Setup -> Motor Options

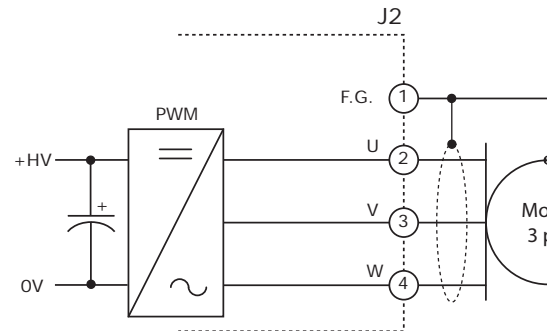
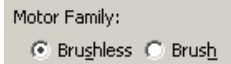

TEMPERATURE SENSOR

The MOTEMP input connects to J3-14 for use with a motor overtemperature switch. The switch or sensor must be grounded so that the input changes from LO to HI when the switch opens. The active level is programmable for use with switches that either open or close when the motor is overheating.

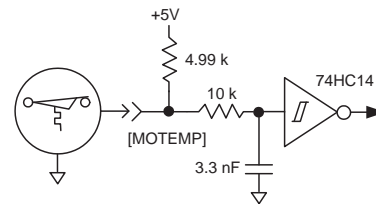

CME2 -> Input / Output



GROUNDING CONSIDERATIONS

Power and control circuits in *Accelnet MACRO* share a common circuit-ground (HV_COM on J1-1, and Signal Ground on J3-2 & 15 and J4-2 & 23). Circuits that are referenced to Signal Ground are the analog Reference input, buffered encoder outputs, motor encoder and Hall signals, and the PWM outputs. For this reason, drive Signal Gnd terminals should connect to the users' common ground system so that signals between drive and controller are at the same common potential, and to minimize noise. The system ground should, in turn, connect to an earthing conductor at some point so that the whole system is referenced to "earth". The MACRO ports are transformer-isolated from the drive circuits.

Because current flow through conductors produces voltage-drops across them, it is best to connect the drive HV Return to system earth, or circuit-common through the shortest path, and to leave the power-supply floating. In this way, the power supply (-) terminal connects to ground at the drive HV Return terminals, but the voltage drops across the cables will not appear at the drive ground, but at the power supply negative terminal where they will have less effect.

Motor phase currents are balanced, but currents can flow between the PWM outputs, and the motor cable shield. To minimize the effects of these currents on nearby circuits, the cable shield should connect to Frame Gnd (J2-1).

The drive frame (heatplate) does not connect to any drive circuits. Connections to the frame are provided on connectors J2-1, J3-1, J4-1. Cables to these connectors should be shielded for CE compliance, and the shields should connect to these terminals. When installed, the drive case should connect to the system chassis. This maximizes the shielding effect of the case, and provides a path to ground for noise currents that may occur in the cable shields.

Signals from controller to drive are referenced to +5 Vdc, and other power supplies in user equipment. These power supplies should also connect to system ground and earth at some point so that they are at same potential as the drive circuits.

The final configuration should embody three current-carrying loops. First, the power supply currents flowing into and out of the drive at the +HV and HV_COM pins on J1. Second the drive outputs driving currents into and out of the motor phases, and motor shield currents circulating between the U, V, and W outputs and Gnd. And, lastly, logic and signal currents connected to the drive control inputs and outputs.

For CE compliance and operator safety, the drive should be earthed by using external tooth lock washers under the mounting screws. These will make contact with the aluminum chassis through the anodized finish to connect the chassis to the equipment frame ground.

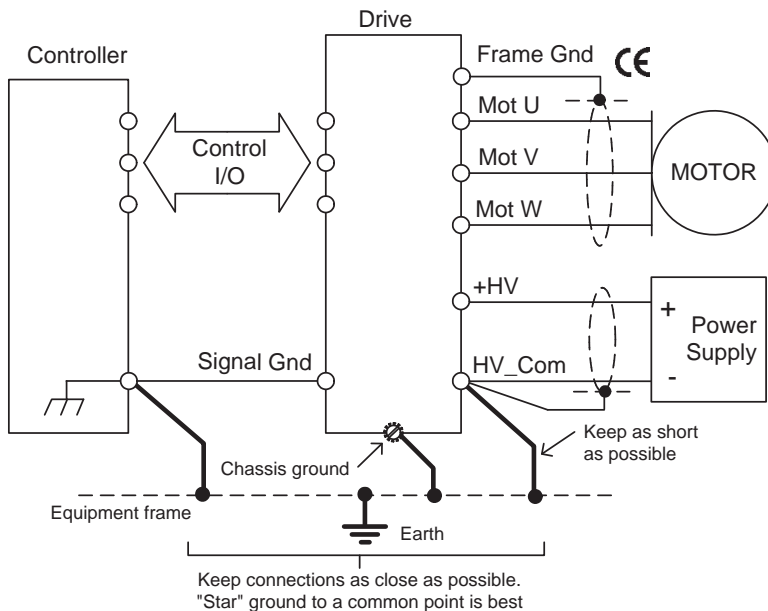

CE = Shielded cables required for CE compliance

POWER SUPPLIES

Accelnet MACRO operates typically from transformer-isolated, unregulated DC power supplies. These should be sized such that the maximum output voltage under high-line and no-load conditions does not exceed the drives maximum voltage rating. Power supply rating depends on the power delivered to the load by the drive. In many cases, the continuous power output of the drive is considerably higher than the actual power required by an incremental motion application.

Operation from regulated switching power supplies is possible if a diode is placed between the power supply and drive to prevent regenerative energy from reaching the output of the supply. If this is done, there must be external capacitance between the diode and drive.

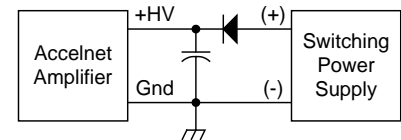

AUXILIARY HV POWER

Accelnet MACRO has an input for HV_AUX. This is a voltage that can keep the drive communications and feedback circuits active when the PWM output stage has been disabled by removing the main +HV supply. This can occur during EMO (Emergency Off) conditions where the +HV supply must be removed from the drive and powered-down to ensure operator safety. The HV_AUX input operates from any DC voltage that is within the operating voltage range of the drive and powers the DC/DC converter that supplies operating voltages to the drive DSP and control circuits.

When the drive +HV voltage is greater than the HV_AUX voltage it will power the DC/DC converter. Under these conditions the HV_AUX input will draw no current.

MOUNTING & COOLING

Accelnet MACRO has slots for mounting to panels at 0° or 90°. Cooling is by conduction from drive heatplate to mounting surface, or by convection to ambient.

A heatsink (optional) is required for the drive to deliver the rated continuous output current. Depending on the drive mounting and cooling means this may not be required.

CONNECTORS & SIGNALS

J4: CONTROL

J4 SIGNALS	PIN
Frame Ground	1
Signal Ground	2
Enable HS [IN1]	3
HS [IN2]	4
HS [IN3]	5
HS [IN4]	6
HS [IN5]	7
HS [IN6]	8
HS [IN7]	9
HS [IN8]	10
HS [IN9]	11
HS [OUT4]	12
GP [OUT1]	13

J3: FEEDBACK

J3 SIGNALS	PIN
Frame Ground	1
Signal Ground	2
+5 Vdc @ 400 mA	3
Encoder A	4
Encoder /A	5
Encoder B	6
Encoder /B	7
Encoder In/Out X	8
Encoder In/Out /X	9
Encoder Input S	10

J1: POWER

J1 SIGNALS	PIN
HV_COM	1
+HV	2
HV_AUX	3

J1 CABLE CONNECTOR:

3 position 5.08 mm Euro-Style plug
 Copley: 57-00465-000
 PCD: ELFP03210
 Ria: 31249103
 Weco: 121-A-111/03

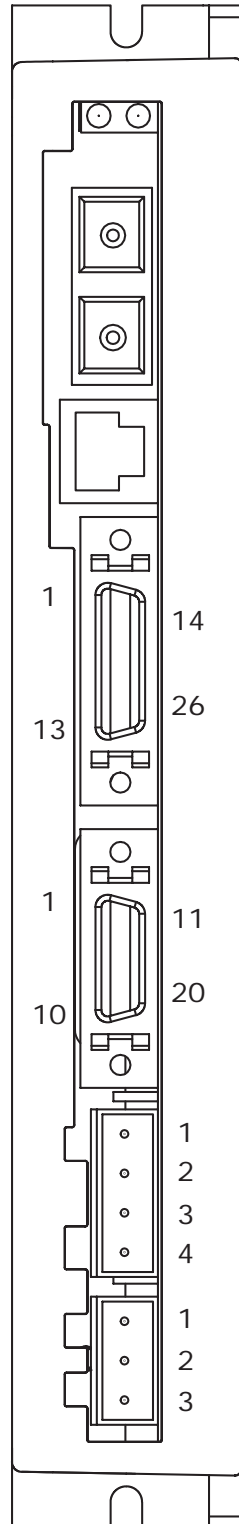

Note:

1. The total +5 Vdc output current from J3-3 and J4-22 cannot exceed 400 mA.

J4: CONTROL

PIN	J4 SIGNALS
14	GP [OUT2]
15	GP [OUT3]
16	Multi-mode Encoder A
17	Multi-mode Encoder /A
18	Multi-mode Encoder B
19	Multi-mode Encoder /B
20	Multi-mode Encoder X
21	Multi-mode Encoder /X
22	+5 Vdc @ 400 mA
23	Signal Ground
24	[Ref+]
25	[Ref-]
26	GP [IN10]

J3: FEEDBACK

PIN	J3 SIGNALS
11	Hall U
12	Hall V
13	Hall W
14	Motemp [IN11]
15	Signal Ground
16	Analog Sin(+)
17	Analog Sin(-)
18	Analog Cos(+)
19	Analog Cos(-)
20	Encoder Input /S

J2: MOTOR

PIN	J2 SIGNALS
1	Frame Gnd
2	Motor U
3	Motor V
4	Motor W

J2 CABLE CONNECTOR:

4 position 5.08 mm Euro-Style plug
 Copley: 57-00466-000
 PCD: ELFP04210
 Ria: 31249104
 Weco: 121-A-111/04

J4 CABLE CONNECTOR:

Solder Cup, 26 position male, 1.27 mm pitch
 Cable: 26 conductor, shielded
 Standard with Snap locks
 3M: 10126-3000 VE connector
 3M: 10326-52F0-008 backshell
 Rugged with Screw-locks
 Molex: 54306-2619 connector
 Molex: 54331-0261 backshell

Note: Molded cable assemblies are available for J3 & J4. See p. 10 for cable colors.

ACCESSORY CABLE CONNECTIONS

SIGNAL CABLE (AMP-CC-10)

Cable assembly: CCC p/n 59-00785-000
Molded connector mates with drive J4 and has flying-lead terminations.

CONNECTOR (FRONT VIEW)

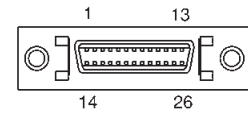

Signal	Pin	Color (Body/Stripe)	Pair		Color (Body/Stripe)	Pin	Signal
Frame Ground	1	Rev A & B: White/Tan Rev C: Brown	1a	8a	White/Violet	14	[OUT2] GP
Signal Ground	2	Rev A & B: Tan/White Rev C: Orange	1b	8b	Violet/White	15	[OUT3] GP
Enable [IN1]	3	White/Brown	2a	9a	White/Grey	16	Multi-Encoder A
GP Input [IN2]	4	Brown/White	2b	9b	Gray/White	17	Multi-Encoder /A
GP Input [IN3]	5	White/Pink	3a	10a	Tan/Brown	18	Multi-Encoder B
GP Input [IN4]	6	Pink/White	3b	10b	Brown/Tan	19	Multi-Encoder /B
HS Input [IN5]	7	White/Orange	4a	11a	Tan/Pink	20	Multi-Encoder X
HS Input [IN6]	8	Orange/White	4b	11b	Pink/Tan	21	Multi-Encoder /X
HS Input [IN7]	9	White/Yellow	5a	12a	Tan/Orange	22	+5 Vdc @ 400 mA
HS Input [IN8]	10	Yellow/White	5b	12b	Orange/Tan	23	Signal Ground
HS Input [IN9]	11	White/Green	6a	13a	Tan/Yellow	24	Analog Ref(+)
HS [OUT4]	12	Green/White	6b	13b	Yellow/Tan	25	Analog Ref(-)
GP [OUT1]	13	White/Blue	7a	7b	Blue/White	26	[IN10] GP Input

FEEDBACK CABLE (AMP-FC-10)

Cable assembly: CCC p/n 59-00786-000
Molded connector mates with drive J3 and has flying-lead terminations.

CONNECTOR (FRONT VIEW)

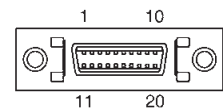

Signal	Pin	Color (Body/Stripe)	Pair		Color (Body/Stripe)	Pin	Signal
Frame Ground	1	Rev A & B: White/Tan RevC: Brown	1a	1b	Rev A & B: Tan/White Rev C: Orange	11	Digital Hall U
Signal Ground	2	White/Brown	2a	7a	White/Blue	12	Digital Hall V
+5 Vdc @ 400 mA	3	Brown/White	2b	7b	Blue/White	13	Digital Hall W
Encoder Input A	4	White/Pink	3a	8a	White/Violet	14	[IN11] Temp Sensor
Encoder Input /A	5	Pink/White	3b	8b	Violet/White	15	Signal Ground
Encoder Input B	6	White/Orange	4a	9a	White/Gray	16	Analog Sin(+)
Encoder Input /B	7	Orange/White	4b	9b	Gray/White	17	Analog Sin(-)
Encoder Input X	8	White/Yellow	5a	10a	Tan/Brown	18	Analog Cos(+)
Encoder Input /X	9	Yellow/White	5b	10b	Brown/Tan	19	Analog Cos(-)
Encoder Input S	10	White/Green	6a	6b	Green/White	20	Encoder Input /S

Note: Cable shields connect to connector shells and not to conductors. The shells of drive J7 & J8 are connected to the earth ground terminal on power connector J1 and to the drive chassis. When the cables above are connected to the drive a continuous path from cable shield to earth is established for shielding and CE compliance.

POWER DISSIPATION

The charts on this page show the amplifier internal power dissipation for the *Accelnet* models under differing power supply and output current conditions. Amplifier output current is calculated from the motion profile, motor, and load conditions. The values on the chart represent the RMS (root-mean-square) current that the amplifier would provide during operation. The +HV values are for the average DC voltage of the amplifier power supply.

When +HV and amplifier output current are known, the amplifier power dissipation can be found from the chart. Once this is done use the data on the facing page to find amplifier thermal resistance. From this calculate the maximum ambient operating temperature. If this result is lower than the known maximum ambient temperature then a mounting with a lower thermal resistance must be used.

When the amplifier is disabled the power dissipation is shown on the chart as "Off". Note that this is a different value than that of an amplifier that is "On" but outputting 0 A current.

55 & 90 VDC MODELS

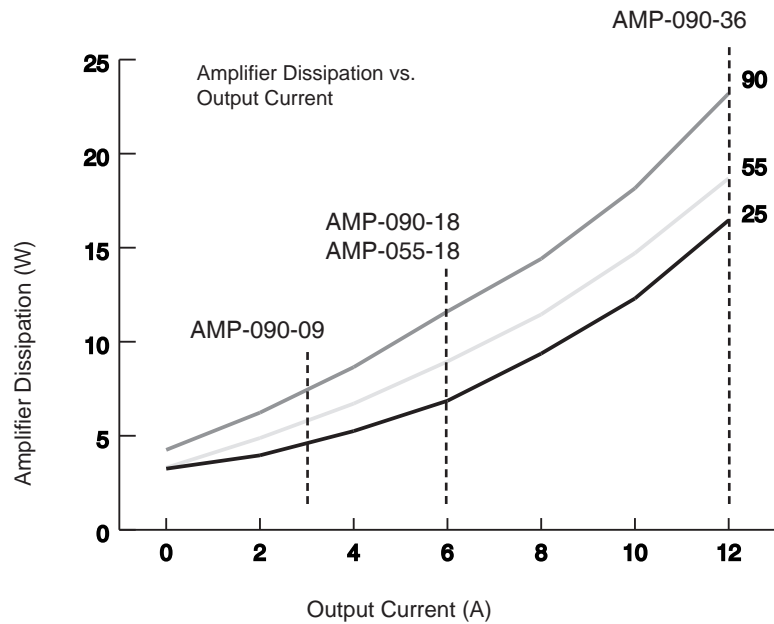

180 VDC MODELS

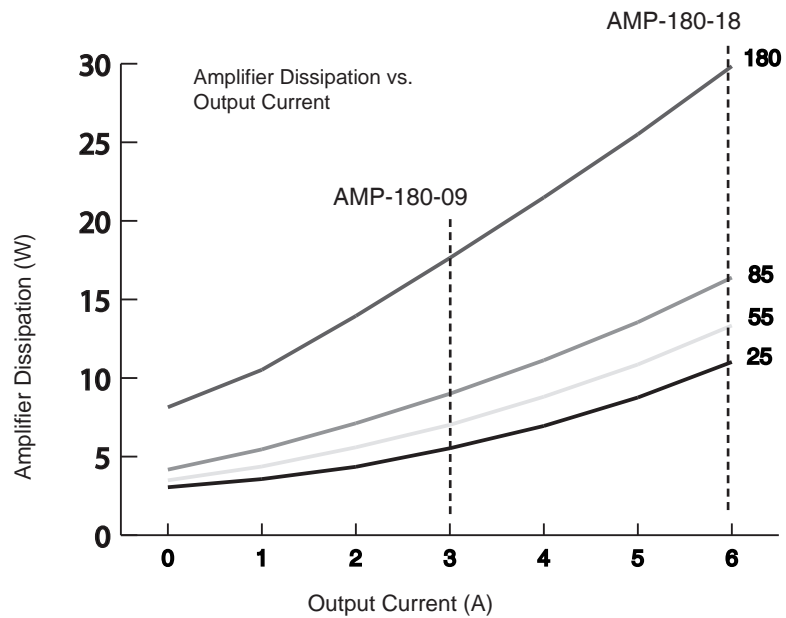

MOUNTING

Thermal data for convection-cooling with a heatsink assumes a vertical mounting of the amplifier on a thermally conducting surface. Heatsink fins run parallel to the long axis of the amplifier. When fan-cooling is used vertical mounting is not necessary to guarantee thermal performance of the heatsink.

THERMAL RESISTANCE

Thermal resistance is a measure of the temperature rise of the amplifier heatplate due to power dissipation in the amplifier. It is expressed in units of °C/W where the degrees are the temperature rise *above ambient*.

E.g., an amplifier dissipating 16 W mounted with no heatsink or fan would see a temperature rise of 46 °C above ambient based on the thermal resistance of 2.9 °C/W. Using the amplifier maximum heatplate temperature of 70 °C and subtracting 46 °C from that would give 24 °C as the maximum ambient temperature the amplifier in which the amplifier could operate before going into thermal shutdown. To operate at higher ambient temperatures a heatsink or forced-air would be required.

END VIEWS VERTICAL MOUNTING

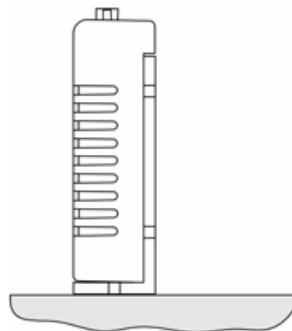

NO HEATSINK, NO FAN	°C/W
CONVECTION	2.9

TOP VIEW VERTICAL MOUNTING WITH FAN

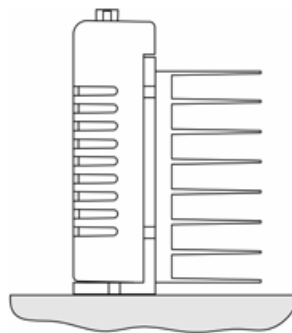
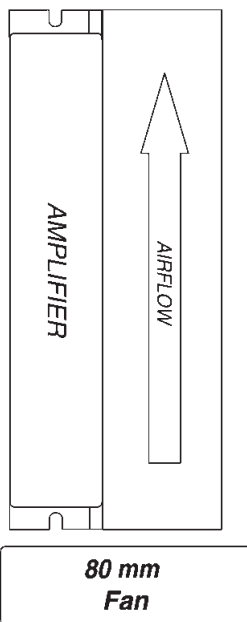

HEATSINK, NO FAN	°C/W
CONVECTION	1.7

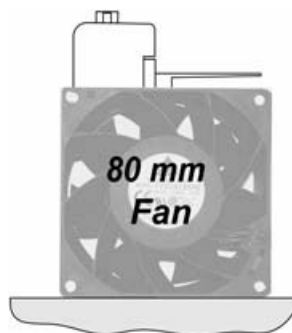

HEATSINK + FAN	°C/W
FORCED-AIR, 300 LFM	0.6

DIMENSIONS

NOTES

1. Dimensions shown in inches [mm].

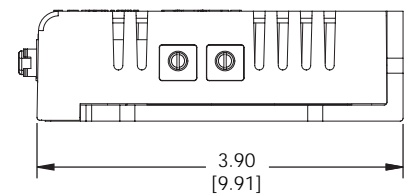
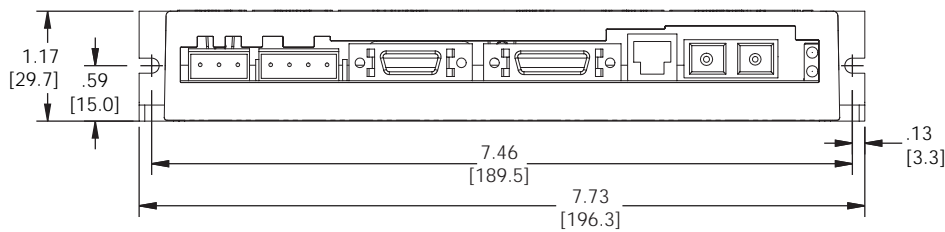
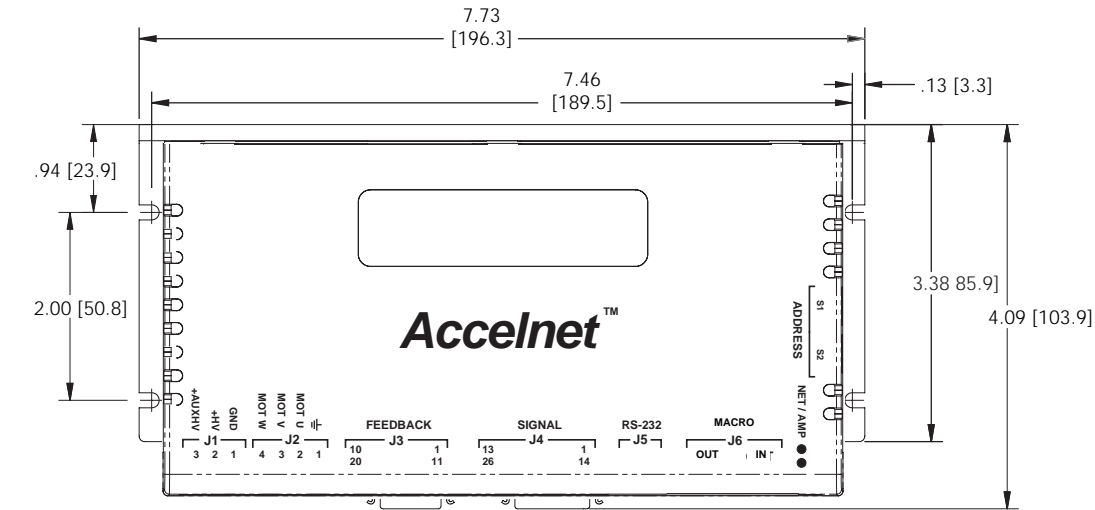

Weights:

Drive: 0.94 lb (0.43 kg)
Heatsink: 1.0 lb (0.45 kg)

MASTER ORDERING GUIDE

AMP-055-18	Accelnet MACRO Servo drive, 55 Vdc, 6/18 A
AMP-090-09	Accelnet MACRO Servo drive, 90 Vdc, 3/9 A
AMP-090-18	Accelnet MACRO Servo drive, 90 Vdc, 6/18 A
AMP-090-36	Accelnet MACRO Servo drive, 90 Vdc, 12/36 A
AMP-180-09	Accelnet MACRO Servo drive, 180 Vdc, 3/9 A
AMP-180-18	Accelnet MACRO Servo drive, 180 Vdc, 6/18 A

ACCESSORIES

	QTY	REF	DESCRIPTION	MANUFACTURER PART NO.
Connector Kit Solder-Cup AMP-CK	1	J1	Plug, 3 position, 5.08 mm, female	PCD: ELFP03210, Weco: 121-A-111/03
	1	J2	Plug, 4 position, 5.08 mm, female	PCD: ELFP04210, Weco: 121-A-111/04
	1	J3	20 Pin Connector, High Density, D-Sub, Solder Cup	3M: 10120-3000VE
	1		20 Pin Connector Backshell	3M: 10320-52FO-008
	1	J4	26 Pin Connector, High Density, D-Sub, Solder Cup	3M: 10126-3000VE
	1		26 Pin Connector Backshell	3M: 10326-52FO-008
Connector Kit Cable Assy AMP-CA	1	J1	Plug, 3 position, 5.08 mm, female	PCD: ELFP03210, Weco: 121-A-111/03
	1	J2	Plug, 4 position, 5.08 mm, female	PCD: ELFP04210, Weco: 121-A-111/04
	1	J3	Cable assembly, control, 10 ft (3 m)	Molex: 52316-2611, plug Assy, Molex 52370-2610 boot cover
	1	J4	Cable assembly, feedback, 10 ft (3 m)	Molex: 52316-2011, plug Assy, Molex 52370-2010 boot cover
AMP-CC-10		J3	Cable assembly, control, 10 ft (3 m)	Molex: 52316-2611, plug Assy, Molex 52370-2610 boot cover
AMP-FC-10		J4	Cable assembly, feedback, 10 ft (3 m)	Molex: 52316-2011, plug Assy, Molex 52370-2010 boot cover
SER-CK		J5	Serial Cable Kit: D-Sub 9 female to drive J5 connector, 6 ft (1.8 m)	
CME 2			CME 2™ CD (CME 2)	
Heatsink Kit AMP-HK	1		Heatsink	
	1		Thermal Material	
	A/R		Hardware	

Note: To order drive with heatsink installed at factory, add "-H" to the drive part number. E.g., AMP-090-09-H

ORDERING INSTRUCTIONS

Example: Order 1 AMP-090-18 drive with heatsink installed at factory and associated components:

Qty	Item	Remarks
1	AMP-090-18-H	Accelnet MACRO servo drive
1	AMP-CA	Connector Kit with molded cables for control & feedback
1	SER-CK	Serial Cable Kit
1	CME2	CME 2™ CD