



EtherCAT

User Guide



16-01450
Revision 01
July 11, 2019

Important:

The contents of this manual are valid from the firmware versions listed below:

- AEM:
- AE2:
- BEL:
- BE2:
- SEM:
- SE2:
- TEL:
- TE2:
- XEL:
- XE2:

Trademarks:

- *EtherCAT* is a registered trademark and patented technology, licensed by Beckhoff Automation GmbH, Germany
- *Windows* is a registered trademark of Microsoft Corporation
- *Copley ASCII Interface, Copley Virtual Machine, CVM, Accelnet, Xenus, Stepnet, and CME* are registered trademarks of Copley Controls.
- Other designations used in this publication may be trademarks whose use by third parties for their own purposes could violate the rights of the owners. No part of this document may be reproduced in any form or by any means, electronic or mechanical, including photocopying, without express written permission of Copley Controls.

TABLE OF CONTENTS

1 About This Manual	7
1.1 Title, Number, Revision.....	7
1.2 Revision History	7
1.3 Overview and Scope.....	7
1.4 Comments.....	7
1.5 Document Validity	7
1.6 Copley Controls EtherCAT <i>Plus</i> Servo & Stepper Drives.....	8
2 Related Documentation	9
1.1 References.....	10
2.1.1 Common Abbreviations	11
2.1.2 Network Abbreviations.....	12
3 Introduction to EtherCAT	13
3.1 EtherCAT Technology Group (ETG).....	13
3.2 Standards for EtherCAT and CoE.....	13
3.3 EtherCAT Overview	14
3.3.2 EtherCAT Slave Devices (Copley EtherCAT drives).....	15
3.3.3 CANopen, EtherCAT, and CoE	15
3.4 Elements of an EtherCAT Network.....	16
3.4.1 EtherCAT Master Software.....	16
3.4.2 EtherCAT Master Stacks	16
3.4.3 EtherCAT Configuration Tool.....	16
3.4.4 EtherCAT Physical Layer.....	16
3.4.5 EtherCAT Slave Controllers (ESC).....	16
3.4.6 EtherCAT EEPROM	16
3.4.7 Application Layer Host Controller (a <i>Copley EtherCAT Plus</i> drive).....	17
3.4.8 ESI (EtherCAT Slave Information) File.....	17
3.4.9 Cabling and Connectivity	17
3.5 States	17
3.5.1 Synchronization & Distributed Clocks (DC)	18
3.6 Inside the EtherCAT Drive	19
3.6.1 From the Network to the Drive.....	19
3.6.2 EtherCAT Network Slaves Don't Think.....	19
3.6.3 EtherCAT Time	20
3.6.4 Synchronization Overview	20
Freerun	20
Sync-Manager Synchronization.....	20
Distributed Clocks (DC)	20
Control System Timing and Process Data.....	20
3.7 EtherCAT Data.....	21
Fixed PDOs.....	21
Fixed RxPDOs	21
Fixed TxPDO	21
Not-Fixed, or User Programmable PDOs	22
Un-Fixed RxPDOs	22
Un-Fixed TxPDOs.....	22
3.8 EtherCAT System Architectures	23
Masters that Use ESI Files	23
Masters That Don't Use ESI Files.....	24
4 Setting Up for EtherCAT	25
AC Drive EtherCAT Connectors	25
DC Drive EtherCAT Connectors	25
4.1 EtherCAT Cabling	25
4.2 Indicators: EtherCAT LEDs.....	26
4.3 Device ID Switches & Station Alias.....	26
4.4 Drive Axis Indicators	27
Latching Faults.....	27
4.5 Drive Wiring.....	27

5 Configuring Drives for EtherCAT	28
5.1 Serial RS-232 Connections.....	28
Serial Connection: Xenus AC Powered Drives.....	28
Serial Connection: Accelnet & Steynet DC Powered Drives.....	28
EtherCAT Connections.....	29
5.2 CME2 Installation for EtherCAT.....	29
Download CME2.....	29
Configure the drive for EtherCAT operation.....	30
Motor Set Up.....	31
Enable the drive for EtherCAT control.....	32
Download ESI (EtherCAT Slave Information) Files.....	33
6 EtherCAT Quick Starts	35
6.1 Beckhoff TwinCAT 3.....	35
Introduction.....	35
TwinCAT3 Software.....	35
TC3-Full-Setup.....	37
Install ESI Files.....	40
Confirm that TwinCAT 3 is the Active Runtime.....	40
Assign an Ethernet Port on Your Computer to EtherCAT.....	40
Running TwinCAT 3.....	41
The New Project Screen.....	42
Setting Up the NC Controller.....	47
Encoder Scaling Factor.....	47
NC Axis Settings.....	48
System Real-Time Settings.....	50
RT Kernel Time-Base Stability.....	52
RT Kernel Check #1.....	53
RT Kernel Check #2:.....	53
Activating the Configuration.....	54
NC: Online.....	54
NC: Manual Control.....	55
Jogging.....	55
Single Move: Target Position.....	56
Single Move: Target Velocity.....	56
Single Move: Acceleration/Deceleration.....	56
NC: Setting Absolute Position to Zero.....	56
NC: Out/Back Repeating Positions.....	57
Switching Runtime with TwinCAT 2.....	58
6.2 Beckhoff TwinCAT 2.....	63
Introduction.....	63
Step 1: Configure the Drive for EtherCAT Operation.....	63
Step 2: Download the ESI (XML) File from the Copley web-site.....	63
Step 3: Assign an Ethernet Port on Your Computer to EtherCAT.....	63
Step 4: Download the TwinCAT 2 Software and Install It.....	64
Language selection.....	64
Click-through EULA.....	64
After Welcome, Accept.....	65
Name & Company Entry.....	65
Installation Level Selection.....	66
Version Selection.....	66
Feature Selection.....	67
TwinCAT 2 Destination Folder.....	67
Restart Prompt.....	68
Restart.....	68
System Properties.....	69
System Properties.....	69
Check ESI File Installation.....	70
Installation Is Complete.....	70
Open A New File And Scan For Devices.....	71

Devices Found And Link To Nc Controllers	72
Data Linkage In TwinCAT 2	73
TwinCAT NC Axis	73
Xenus Plus XEL Drive	73
NC Configuration	74
NC Units	74
NC Velocity And Fault Configurations	75
Online Operation Of The NC	76
Enable The Drive	76
Jogging	77
Enable The Drive	77
Simple Motion Without A PLC In TwinCAT 2	78
Simple Motion Without A PLC In TwinCAT 2 (cont'd)	79
What Next???	80
Beckhoff	80
6.3 Delta-Tau Power PMAC	81
Introduction	81
IDE Installation	81
ESI (XML) Files	82
Launch the Power PMAC IDE	82
Local Network Configuration	83
Updating Firmware	84
Start a new PMAC project	85
Reset the Power PMAC	85
System Setup	86
Create a New Setup	86
Reset All Masters and Scan for New Devices on the EtherCAT Network	87
Set System Clock Frequencies	87
Update Device Files	88
Configure Master[0]	89
Amplifiers Set Up	89
General Tab	89
DC Tab	90
Startup Tab	91
1-Axis Drives	91
2-Axis Drives	91
Input PDO Configuration: 1-Axis	92
Input PDO Configuration: 2-Axis	93
Output PDO Configuration: 1-Axis	94
Output PDO Configuration: 2-Axis	95
Motor Configuration	96
Add a New Motor	97
Amplifier Information	97
Motor Information	98
Command/Feedback Information	98
Hardware Interface: 1-Axis Drives	99
Hardware Interface: 2-Axis Drives, Axis A	100
Safety	100
Hardware Interface: 2-Axis Drives, Axis B	101
Safety	101
Create Set-Up Files and Save the EtherCAT Project	102
Export EtherCAT Variables	102
Power PMAC Project File Organization	102
Generate and Save a Configuration File	103
Save All settings to the computer's hard drive.	103
PMAC System Structure	103
Generate and Save the EcatActivate0.cfg File	104
Download the Config Files	104

Save the Configuration	104
Reset the PMAC	104
Command Entries and Response.....	105
Some typical On-Line Commands	105
6.4 Acontis EC-Master Windows: Quick Setup w/ SE2	106
Introduction	106
ESI Files.....	106
Scan the Network for Devices	107
Configure Device PDOs.....	108
Export the ENI File.....	108
Initialize the Drive on the Network	109
Change the Drive State from Init to Operational.....	111
PDO Data from Master to Drive	112
PDO Data from Drive to Master	114

1 ABOUT THIS MANUAL

1.1 Title, Number, Revision

Title	<i>EtherCAT User Guide</i>
Document Number	16-01450
Current Revision	01

1.2 Revision History

Revision	Date	Comments
00	December 21, 2015	Preliminary version
01	July 11, 2019	Acontis EtherCAT added

1.3 Overview and Scope

This manual covers EtherCAT communications as it applies to Copley Controls Plus products. It is written for the reader who has a basic knowledge of motion control theory and operation, Copley Controls servo drives, and Copley Controls CME software.

***** **IMPORTANT** *****

The purpose of this manual is to provide basic information on EtherCAT communications, and to show how EtherCAT master software can be set up with Copley servo drives. All of the Quick Starts use the servo drive as an EtherCAT slave configured for CSP (Cyclic Synchronous Position) mode. Before connecting a Copley servo drive to an EtherCAT master, Basic Setup in the CME software must be configured for:

- ***Operating mode: Position***
- ***Command source: CANopen application protocol over EtherCAT (CoE)***

The drive must be set up with the motor, phased properly, and the position mode tuning adjusted for optimal, stable response. In CSP mode, the servo drive operates as a position-follower with current/velocity/position loops closed in the drive. The EtherCAT master does all of the calculations to produce motion profiles that move the motor to desired positions.

1.4 Comments

The Copley Controls web-site has a link to *comment or ask a question* about this manual:
<http://www.copleycontrols.com/Motion/Contact/support.html>.

1.5 Document Validity

Copley Controls reserves the right to modify our products.
 The information in this document is subject to change without notice and does not represent a commitment by Copley Controls. Copley Controls assumes no responsibility for any errors that may appear in this document.

1.6 Copley Controls EtherCAT Plus Servo & Stepper Drives

Plus Models Feature:

- Absolute encoder feedback
- STO (Safe Torque Off) for Panel models

Xenus Plus Panel EtherCAT 1-Axis (XEL)

XEL-230-18, 6 Adc continuous, 18 Adc peak, 100~230 Vac
 XEL-230-36, 12 Adc continuous, 36 Adc peak, 100~230 Vac
 XEL-230-40, 20 Adc continuous, 40 Adc peak, 100~230 Vac

Xenus Plus Panel EtherCAT 2-Axis (XE2)

XE2-230-20, 10 Adc continuous, 20 Adc peak, 100~230 Vac

Accelnet Plus Panel EtherCAT 1-Axis (BEL)

BEL-090-06, 3 Adc continuous, 6 Adc peak, 14~90 Vdc
 BEL-090-14, 7 Adc continuous, 4 Adc peak, 14~90 Vdc
 BEL-090-30, 15 Adc continuous, 30 Adc peak, 14~90 Vdc

Accelnet Plus Panel EtherCAT 2-Axis (BE2)

BE2-090-06, 3 Adc continuous, 6 Adc peak, 14~90 Vdc
 BE2-090-14, 7 Adc continuous, 14 Adc peak, 14~90 Vdc
 BE2-090-20, 10 Adc continuous, 20 Adc peak, 14~90 Vdc

Accelnet Plus Module EtherCAT 1-Axis (AEM)

AEM-090-06, 3 Adc continuous, 6 Adc peak, 14~90 Vdc
 AEM-090-14, 7 Adc continuous, 14 Adc peak, 14~90 Vdc
 AEM-090-30, 10 Adc continuous, 20 Adc peak, 14~90 Vdc

Accelnet Plus Module EtherCAT 2-Axis (AE2)

AE2-090-06, 3 Adc continuous, 6 Adc peak, 14~90 Vdc
 AE2-090-14, 7 Adc continuous, 14 Adc peak, 14~90 Vdc
 AE2-090-30, 15 Adc continuous, 30 Adc peak, 14~90 Vdc

Stepnet Plus Module EtherCAT 1-Axis (SEM)

SEM-090-07, 5 Adc continuous, 7 Adc peak, 14~90 Vdc
 SEM-090-10, 10 Adc continuous, 10 Adc peak, 14~90 Vdc

Stepnet Plus Module EtherCAT 2-Axis (SE2)

SE2-090-07, 5 Adc continuous, 7 Adc peak, 14~90 Vdc
 SE2-090-10, 10 Adc continuous, 10 Adc peak, 14~90 Vdc

Stepnet Plus Panel EtherCAT 2-Axis (TE2)

TE2-090-07, 5 Adc continuous, 7 Adc peak, 14~90 Vdc
 TE2-090-10, 10 Adc continuous, 10 Adc peak, 14~90 Vdc

The models below have EtherCAT functionality but have not been Conformance Tested and certified.

Stepnet Plus Panel EtherCAT 1-Axis (TEL)

TEL-090-07, 5 Adc continuous, 7 Adc peak, 14~90 Vdc
 TEL-090-10, 10 Adc continuous, 10 Adc peak, 14~90 Vdc

Accelnet Panel EtherCAT 1-Axis (AEP)

AEP-055-18, 6 Adc continuous, 18 Adc peak, 20~55 Vdc
 AEP-090-09, 3 Adc continuous, 9 Adc peak, 20~90 Vdc
 AEP-090-18, 6 Adc continuous, 18 Adc peak, 20~90 Vdc
 AEP-090-36, 12 Adc continuous, 36 Adc peak, 20~90 Vdc
 AEP-180-09, 3 Adc continuous, 9 Adc peak, 20~180 Vdc
 AEP-180-18, 6 Adc continuous, 18 Adc peak, 20~180 Vdc

Note: If available, resolver versions (-R option) of these products are not shown in the listing above.



2 RELATED DOCUMENTATION

The documents listed below can be found on the Support section of the Copley web-site:
<https://www.copleycontrols.com/en/support/>

Documents section, Xenus Plus:

- Xenus Plus Ethercat 1-Axis (XEL) Datasheet*
- Xenus Plus Ethercat 2-Axis (XE2) Datasheet*
- Xenus Plus User Guide*
- Absolute & Serial Encoder Guide*

Documents section, Accelnet Plus Module

- Accelnet Plus EtherCAT 1-Axis Module (AEM) Datasheet*
- Accelnet Plus EtherCAT 2-Axis Module (AE2) Datasheet*

Documents section, Accelnet Plus Panel

- Accelnet Plus EtherCAT 1-Axis Panel (BEL) Datasheet*
- Accelnet Plus EtherCAT 2-Axis Panel (BE2) Datasheet*

Documents section, Stepnet Plus Module

- Stepnet Plus EtherCAT 1-Axis Module (SEM) Datasheet*
- Stepnet Plus EtherCAT 2-Axis Module (SE2) Datasheet*

Documents section, Stepnet Plus Panel

- Stepnet Plus EtherCAT 1-Axis Panel (TEL) Datasheet*
- Stepnet Plus EtherCAT 2-Axis Panel (TE2) Datasheet*

Documents section, Software Documents

- Using CME2*
- CME2 Indexer User Guide*
- Camming User Guide*
- CMO Programmers Guide*
- CME2 Indexer User Guide*
- CML Datasheet*
- CPL User Guide*

Documents section, Communication Protocols

- CANopen Manual*
- ASCII Programmers Guide*
- Parameter Dictionary*

Software Releases section, Firmware & Releases, EDS/ESI section

- EtherCAT (a ZIP file that contains ESI files for the Plus models)*

1.1 References

Wikipedia: EtherCAT

A very good introduction to EtherCAT that covers all of the basic elements and has references to other sources of information:

<https://en.wikipedia.org/wiki/EtherCAT>

EtherCAT Technology Group

<http://ethercat.org/default.htm>

The ETG is a global organization in which OEM, End Users and Technology Providers join forces to support and promote the further technology development. Follow this link for an excellent tutorial on EtherCAT:

<http://ethercat.org/en/technology.html>

CiA DS-402 CANopen device profile for drives and motion control

<https://www.can-cia.org/can-knowledge/canopen/cia402/>

The device profile for drives and motion control defines the functional behavior of controllers for servo drives, frequency inverters, and stepper motors.

CoE: CAN Application protocol over EtherCAT

This is the application protocol used by Copley EtherCAT products.

ETG.6010 Implementation Directive for CiA402 Drive Profile

IEC 61800-7 specifies the CiA-402 drive profile that is mapped to EtherCAT.

This specifies the common behavior of servo drives that use the CiA drive profile.

Note that ETG membership is needed to download this specification.

ETG 2200: EtherCAT Slave Implementation Guide

[ETG2200 Slave Implementation Guide](#)

Technology overview, Network Architecture and Functionality, Slave Implementation procedure

Beckhoff Information System

[Beckhoff Information System](#)

From here, click Download > Beckhoff Information System > Reference in HTML-format Downloads are available for TwinCAT 2 and TwinCAT 3.

These are large files but the Infosystem is available on-line:

[Beckhoff Information System Online](#)

2.1.1 Common Abbreviations

CPU	Central Processing Unit
DC	Distributed Clocks
DPRAM	Dual-Port Random Access Memory
EEPROM	Electrically Erasable Programmable Read-Only Memory
ENI	EtherCAT Network Information (file in XML format)
ESC	EtherCAT Slave Controller
ESI	EtherCAT Slave Information (file in XML format)
ESM	EtherCAT State Machine (Init, Pre-Op, Safe-Op, Op)
ETG	EtherCAT Technology Group
FMMU	Fieldbus Memory Management Unit
FoE	File Access over EtherCAT
FPGA	Field Programmable Gate Array
GPIO	General-Purpose Input/Output
IEC	International Electrotechnical Commission
IP Core	Intellectual Property Core (licensed EtherCAT code in the FPGA)
MDP	Modular Device Profile
MII	Media Independent Interface
NIC	Network Interface Card (Ethernet port/card in a desktop PC)
NVRAM	Non-Volatile Read-Only Memory
OEM	Original Equipment Manufacturer
PDI	Process Data Interface
PDO	Process Data Object
PHY	PHYSical circuit interface between internal logic and network signals
PLC	Programmable Logic Controller
SII	Slave Information Interface (EEPROM)
USB	Universal Serial Bus
XML	Extended Mark-Up Language

2.1.2 Network Abbreviations

The reference for these abbreviations is the EtherCAT Specification - Part 3 Data Link Layer service definition, ETG.1000.3 S (R) V1.0

AL	Application Layer
APRD	Auto Increment Physical Read
APRW	Auto Increment Physical Read/Write
APWR	Auto Increment Physical Write
ARMW	Auto Increment Physical Read Multiple Write
BRD	Broadcast Read
BRW	Broadcast Read Write
BWR	Broadcast Write
CoE	CANopen Application layer over EtherCAT
ECAT	Prefix for DL services & protocols
EEPROM	Electrically Erasable Programmable Read-Only Memory
EtherCAT	Ethernet for Control Automation Technology
FPRD	Configured Address Physical Read
FPRW	Configured Address Physical Read/Write
FPWR	Configured Address Physical Write
FRMW	Configured Address Physical Read Multiple Write
LRD	Logical Memory Read
LRW	Logical Memory Read/Write
LWR	Logical Memory Write
MII	Media Independent Interface
PHY	Physical Layer (of a network: cables, sockets, etc)
TCP/IP	Transmission Control Protocol / Internet Protocol
UDP	User Datagram Protocol

3 INTRODUCTION TO ETHERCAT

"EtherCAT is the open real-time Ethernet network originally developed by Beckhoff."

These words can be found on the [EtherCAT Technology Group \(ETG\)](#) web-site which is the organization set up by Beckhoff to support and promote EtherCAT. ETG is a source for information on EtherCAT, its operation and specifications, provides training classes and promotes it in trade shows.

First-time users of EtherCAT should read the [Technical Introduction and Overview](#) section of the ETG site for a short course in this technology.

3.1 EtherCAT Technology Group (ETG)

ETG is the knowledge base for the EtherCAT specifications and other documents describing EtherCAT operation and applications. Users of Copley Controls EtherCAT products should become familiar with this web-site as the primary source of information and specifications that apply to EtherCAT.

In 1986 Beckhoff GmbH produced the first PC-based motion controller. In 1996 TwinCAT software was introduced with a real-time kernel, NC and PLC functions integrated for motion control. EtherCAT was then produced in 2003 to provide a high-speed, Ethernet based fieldbus system which allowed high-speed updating of process data for motion control and I/O, as well as tight synchronization of the servo drives on the network. The ETG was created to separate the production, management, and promulgation of the EtherCAT specification from Beckhoff GmbH which produces primarily hardware.

Copley Controls is a member of the ETG, and participates yearly in Plug Fests during which members have the opportunity to test the function and compatibility of their products with those of other members.

ETG Home

Web-site for EtherCAT Technology Group

EtherCAT: The Ethernet Fieldbus

A good brochure about EtherCAT and the basic features of the technology

ETG 2200: Slave Implementation Guide

This document describes the first steps with EtherCAT when starting an EtherCAT slave implementation.

EtherCAT Introduction

Graphic PowerPoint about EtherCAT features

Industrial Ethernet Technology Comparison

A detailed presentation of EtherCAT vs. Profinet, Ethernet/IP, CC-Link I.e., Sercos III, Powerlink, and Modbus/TCP

EtherCAT Functional Principle

An animated demonstration of EtherCAT operation. Puts the FUN in functional.

3.2 Standards for EtherCAT and CoE

IEC standards that relate to the operation of Copley Controls EtherCAT drives that use CoE.

The EtherCAT standards are international standards available from the IEC:

<http://www.iec.ch/index.htm>

IEC 61800-7: Generic Interface and use of Profiles for Power Drive Systems

IEC 61800-7-1: Interface Definition

IEC 61800-7-1 Annex A: Mapping to CiA 402

IEC 61800-7-2xx: Profile Specifications

IEC 61800-7-201: Profile CiA 402

IEC 61800-7-3xx: Mapping of profiles to network topologies

IEC 61800-7-301: Mapping to EtherCAT, CANopen

CoE: CANopen application protocol over EtherCAT

CAN in Automation (CAN-CiA) is the international users' and manufacturers' organization that develops and supports CAN-based higher-layer protocols such as CAN and CANopen: <http://www.can-cia.org/>.

3.3 EtherCAT Overview

These are the components of an EtherCAT system. A single EtherCAT master controls a number of EtherCAT slaves (also called nodes or devices) on the network. The master transmits EtherCAT frames that can contain a number of EtherCAT datagrams. Each datagram holds the process data for a specific slave. Process data frames are sent at a constant, cyclic rate. Inside the master, there can be more than one real-time task with each real-time task running at its own cyclic rate.

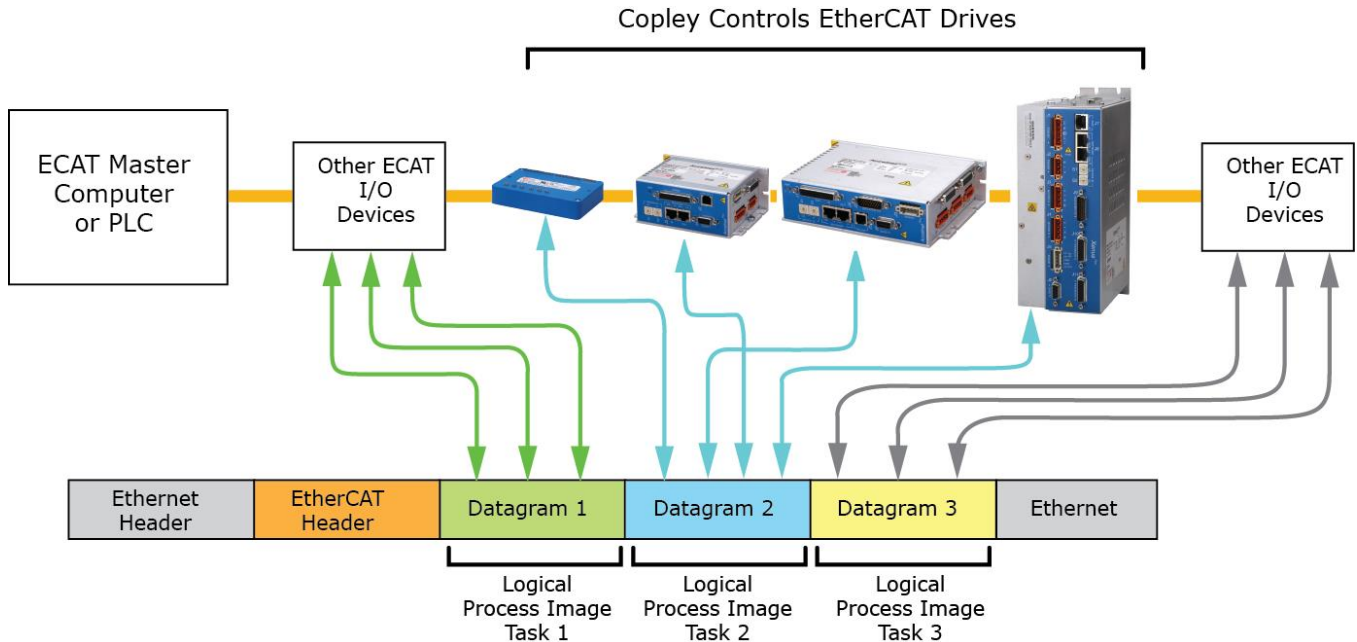

Starting Up Step-by-Step

- Install the EtherCAT master software
- Place ESI files in master software folder
- Dedicate a NIC (Network Interface Card) to EtherCAT
- Connect EtherCAT devices from Master to Slaves
- Configure slaves for EtherCAT operation and turn on, prepare for EtherCAT operation
- Master scans network. Devices found that have matching ESI files may be linked automatically to NC's
- Configure slaves from the master with units and features appropriate with NC controllers
- Activate the Master configuration, downloading it to a RT (Real-Time) kernel
- Enable slaves from Master.
- Create an application program that controls the drives and I/O to control the user's machine

Note: Beckhoff TwinCAT masters automatically link Copley EtherCAT drives to NC controllers that produce the cyclic synchronous position data for the drives. Other EtherCAT masters may have different actions during the configuration.

3.3.2 EtherCAT Slave Devices (Copley EtherCAT drives)

First, some definitions:

- *Layers* characterize and standardize a communication system.
- *Protocols* are the rules for data transmission and reception.
- *Profiles* define the functional behavior of the device.

Copley Plus EtherCAT drive operate under the CANopen application protocol over EtherCAT (CoE).

NETWORK PHYSICAL LAYER

This is the lowest layer that receives and transmits the electrical network signals. The PHY (Physical) circuits convert EtherCAT frames into internal logic signals which read from, or write to DPRAM (Dual-Port RAM) memory. This is done on the fly and completely in hardware with no delays or connection to internal firmware.

ESC (EtherCAT Slave Controller) Data Link Layer

The DPRAM information is read/written by the firmware. Data written into DPRAM will be transferred to the next datagram passing through on the network. And data transferred to the DPRAM from the network is available to read by the firmware at any time between successive write operations. An EEPROM is implemented in the FPGA and the networks status LEDs are controlled by the IP core.

DRIVE APPLICATION LAYER

This is the layer that is actively exchanging data with the EtherCAT master which is running an application for an overall machine-control function. This is the level at which CoE applies.

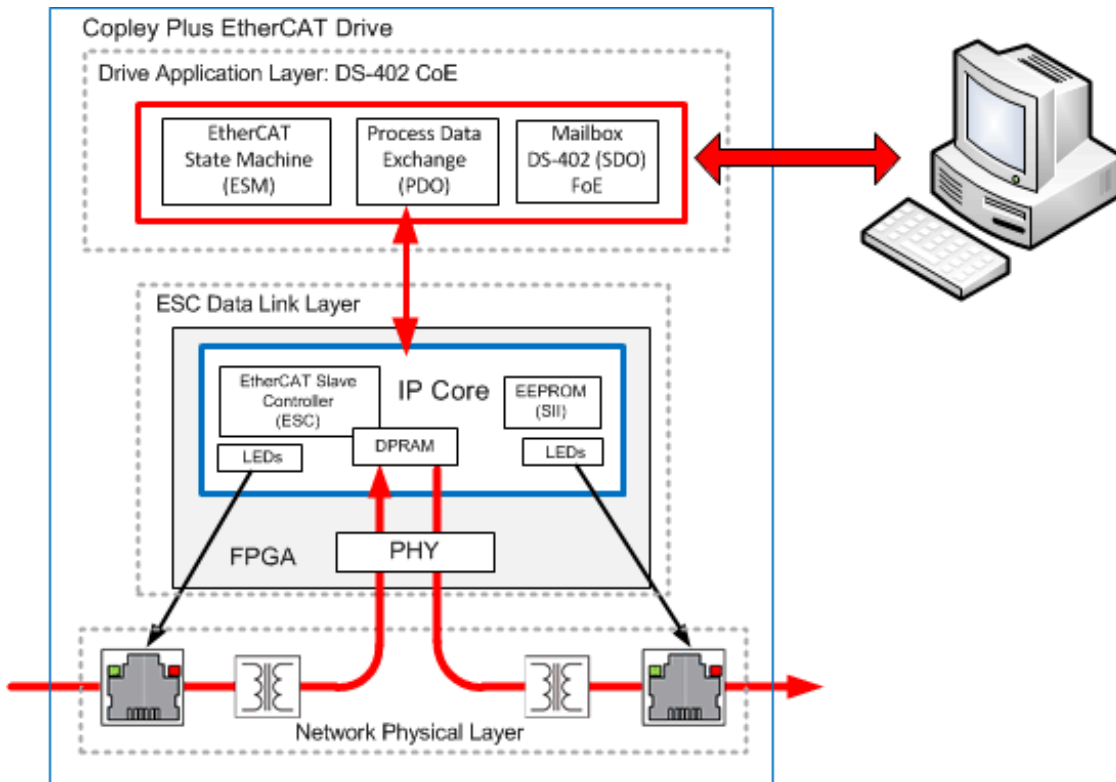

3.3.3 CANopen, EtherCAT, and CoE

CoE is the abbreviation for *CANopen application protocol over EtherCAT*.

A *Protocol* defines a message format and the rules for the exchange of data. DS-402 is the device profile for drives and motion control which includes Copley servo and stepper drives. CoE carries this well-proven profile from CANopen to the EtherCAT environment where it operates at much higher speeds. This shortens the learning curve and builds upon a feature set that has wide acceptance. Users upgrading from CANopen to EtherCAT don't have to learn a new control language.

3.4 Elements of an EtherCAT Network

3.4.1 EtherCAT Master Software

Fully featured masters typically incorporate the following elements:

- Bus-scanning for network topology
- ESI file usage for device configuration during scanning (Typically, but not all masters use ESI files)
- Device initialization via Mailbox (SDO) commands
- Distributed Clocks (DC) for synchronization over the network
- Cyclic synchronous PDO commands from the real-time kernel
- Real-time kernel with multiple tasks operating at different cycle times
- NC (Numerical Control) for motion-control (trajectory generation, PID, virtual drives)
- PLC for overall control (IEC 61131 multi-language programming environment)

3.4.2 EtherCAT Master Stacks

Stacks are a class of EtherCAT masters that provide a user's application software a connection to the EtherCAT network. The user then develops their own higher level control program with features designed for their particular applications. Master Stacks may rely on Beckhoff's Configuration Tool software that uses the ESI files from the EtherCAT slave manufacturer to scan the network and produce an ENI (EtherCAT Network Information) file. The result is a high level language interface between the user's application and the physical layer of the network.

3.4.3 EtherCAT Configuration Tool

Beckhoff software that generates ENI (EtherCAT Network Information) files based on the ESI (EtherCAT Slave Information) files, and the slaves discovered after scanning the network. ENI files describe the network topology, initialization (SDO) commands for each device, and cyclic (PDO) commands. Used most often by masters that don't use ESI files and don't have the ability to scan the network for slaves. ENI files are in XML format as are ESI files.

3.4.4 EtherCAT Physical Layer

Copley *EtherCAT Plus Panel* drives all use the Ethernet 100BASE-TX layer which use CAT5 (or higher) standard Ethernet cables and RJ45 connectors on the drives. *EtherCAT Plus Modules* which are designed for mounting on the user's PC board can mount on Development Kits which are equipped with the same RJ45 connectors. All of the *EtherCAT Plus* Products have internal magnetics for isolation from the network and PHYs that manage the reception and transmission of EtherCAT frames.

3.4.5 EtherCAT Slave Controllers (ESC)

Copley *EtherCAT Plus* drives implement the ESC as an *IP Core* in the FPGA which also contains a DSP (Digital Signal Processor) which is the control core of the drive.

3.4.6 EtherCAT EEPROM

Implemented as a *virtual* EEPROM in the FPGA, it contains some basic information about the drive which master software may use.

3.4.7 Application Layer Host Controller (a Copley EtherCAT Plus drive)

The part of the *EtherCAT Plus Drive* firmware that handles the EtherCAT tasks:

- EtherCAT State Machine (ESM) that manages the INIT, PREOP, SAFEOP, and OP states
- PDO data transmit/receive
- Mailbox data exchange (CoE, FoE)

3.4.8 ESI (EtherCAT Slave Information) File

The *Modular Device Profile* is defined in ETG5001-1:

Aka "modules and slots". Works with EtherCAT masters that support this feature. These contain complete SDO, PDO, and Object Dictionaries for each axis (see below) in addition to the MDP objects.

There are two types of ESI files provided for each *EtherCAT Plus* drive:

- Flat: No MDP, and these no MDP objects in the file. These follow the CiA DS-301 CANopen standard in which PDOs for Axis B are offset by 0x40 from Axis A PDOs. And, the Object Dictionary for Axis B is offset by 0x800 from the Object Dictionary of Axis A.
- Slots: With MDP, aka "modules and slots". Works with EtherCAT masters that support this feature. These contain complete SDO, PDO, and Object Dictionaries for each axis (see below) in addition to the MDP objects.

This graphic shows the ESI file folders after un-zipping the *ecatxml.zip* folder from the Copley web-site:

 flat	3/5/2014 1:41 PM	File folder
 slots	3/5/2014 1:41 PM	File folder
 readme.txt	3/5/2014 1:41 PM	Text Document

3.4.9 Cabling and Connectivity

The physical layer of an EtherCAT network that uses copper cabling is 100BASE-TX. Also called *Fast Ethernet*, it uses CAT5 (or higher rated) cables and has a transmission rate of 100 Mbit/sec. Maximum cable length allowed between nodes is 100 metre. The delay through a 100 m cable is about 0.52 usec.

In the context of many industrial networks, this is not a significant delay that affects performance.

Connections can be line, tree, or star. Unlike CANopen, no terminators are required. And, the master interface hardware is a commonly available NIC (Network Interface Card).

If the cabling is connected in a ring, then two NICs can be used to provide redundancy and identify the location of a break in the network so it can be located and corrected quickly.

3.5 States

The *State* of something is the answer to the question "What is it doing?"

An EtherCAT system consists of three basic components, each of which have *states*:

- Master RT (Real Time) kernels: Start, Stop, Config
- Network:
- Slaves: Init, Pre-Op, Safe-Op, Op

3.5.1 Synchronization & Distributed Clocks (DC)

Question: in a network full of clocks, which clock is the best?

Answer: in most cases, it's a slave clock, not the master's as one might expect.

Why? EtherCAT slaves are single-purpose devices. They have one task to manage, and all the resources are devoted to that task. Compare this to a PC which has a highly variable and unpredictable task load and an equally variable hardware basis in which to manage those tasks.

And, in order to control power dissipation in the CPU and/or optimize battery life, the running speed of the CPU clock in laptop computers can vary widely during operation.

Distributed Clocks are a solution to this situation and are able to provide synchronization that holds jitter to the nanosecond range. Assuming that a slave is selected to be the DC master, all of the other devices can set their clocks to that slave's clock. And in Copley drives, if the slave master clock is synchronized to the position/velocity loop period of 250 usec, then all of the other devices will be controlling position/velocity/current at the same time.

Copley drives have two internal frequencies and 1/F times that are relevant to EtherCAT operation: 16 kHz (62.5 μs) for the current-loop and 4 kHz (250 μs) for the velocity and position loops.

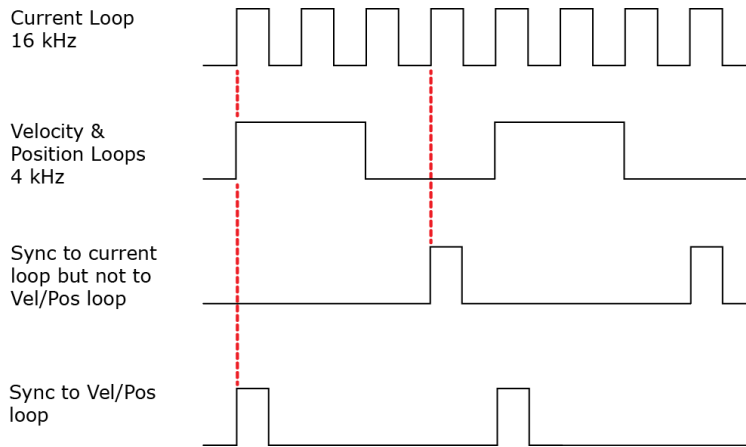

DC syncing between drives using one slave as the DC clock master works best when they sync to the Vel/Pos loops. If syncing is done to the Current loop, drive will operate at the same frequency at the clock master, but motion control loops will not be synchronized. Using the Vel/Pos loop as the DC clock master enable all drives to do motion control with no time-shift between them.

3.6 Inside the EtherCAT Drive

3.6.1 From the Network to the Drive

This diagram shows how the EtherCAT function operates in the drive. The PHY is the PHYSical connection between the network and the ESC (EtherCAT Slave Controller) which is implemented in an FPGA. Data in the ESC is either SDO (Service Data Objects) or PDO (Process Data Objects). SDOs are usually sent at asynchronous time intervals (green) and are used for PDO mapping and setting mode of operation most of the time. They also support FoE (File over EtherCAT). PDO data is exchanged synchronously (yellow) at a rate determined by the cyclic task in the master.

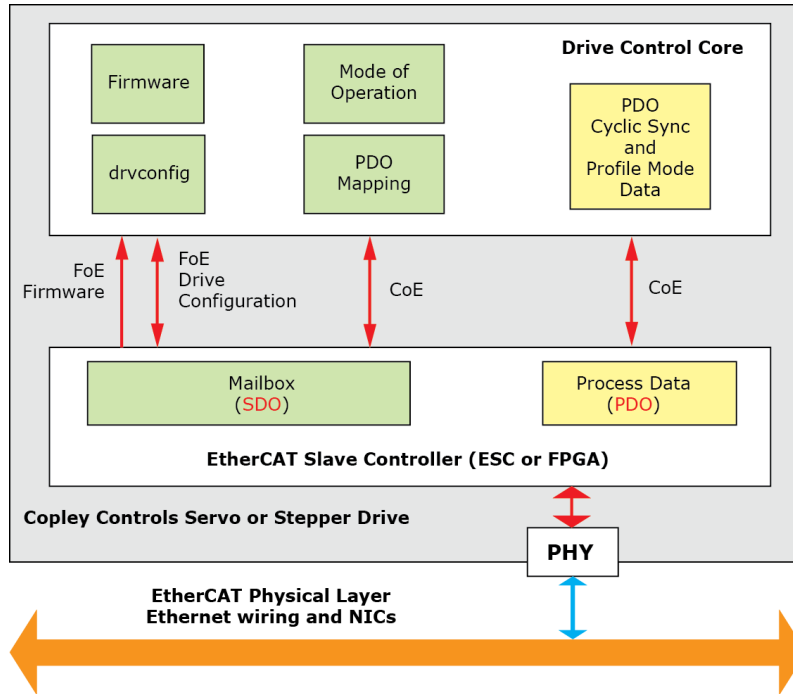

3.6.2 EtherCAT Network Slaves Don't Think

EtherCAT using standard Ethernet cabling produces a control network that moves data at high speed and enables tight synchronization of the devices operating on the network. Here's how it works.

On some networks, a data frame is received, processed by the device's control core, and then re-transmitted. This processing or "thinking" take time, a lot of it relatively speaking. And, because all slaves see the same data at about the same time (I.e. CANopen), a frame has to be sent to each slave individually. This adds up to a lot of network traffic every time it's desired to update all the slaves.

In EtherCAT, each node has an EtherCAT Slave Controller (ESC) that works together with a network PHY (PHYSical layer) chip. Next, the EtherCAT frame typically contains all of the process for all of the slaves, not just one. As the frame passes through the slave, the ESC identifies the data for the slave. Incoming data is stripped from the frame and deposited in dual-port RAM. Outgoing data is deposited in the frame in the section reserved for the slave. All of this is done in hardware without any computation by the slave. The in/out transit time for the frame to move through the slave is fast, less than 1 microsecond.

After the slave data is exchanged, it can begin the computations to process the incoming data. But all of this is "off-line" from the viewpoint of the network and does not impose any delays on the actual data transmission over the network.

3.6.3 EtherCAT Time

As Albert Einstein discovered... time is *relative*. Any discussion of time has to begin with how and where it's measured. All of the devices on an EtherCAT network have digital control cores and each of those has a clock. Each of those clocks measures time based on quartz crystal oscillators and it's practically a certainty that none of the clocks measure time exactly the same. Viewed from any point in the network, master or slave, all of the "other" clocks appear to be running fast or slow.

Next, commands from the master to the network typically travel over copper cabling that has intrinsic delays because electric signals travel slower than the speed of light. And, there is the time that it takes for an EtherCAT frame to enter the slave device. Given all of this, how is it possible for devices on a network to set all their clocks to the same time? And, once that's done how can they all synchronize their operation when multiple axes are product multi-dimensional vector motions?

3.6.4 Synchronization Overview

Timing and synchronization in an EtherCAT network takes three forms:

Freerun

Slaves run 'free' with no connection to the timing of the master or other slaves. They may have internal tasks that don't require a connection to the master. Freerun is used before the real-time kernel is activated. The master will query the slaves on the network, reading their status and CoE objects but will not transmit data to the slaves.

Sync-Manager Synchronization

The slave reacts to telegrams from the master, receiving or transmitting data from sync managers. The timing can vary based on the master's timing which depends on the host computer's CPU clock. Other tasks that may have higher priority in the operating system affect the timing of the sync managers and laptops constantly "throttle" the CPU clock to save power. This is the sync-mode that results when the real-time kernel is activated but Distributed Clocks are not enabled. PDO are reading/writing to the slaves and the network is fully "up" and running. But, the time between cyclic data transfers will have jitter and delays due to cabling will occur.

Distributed Clocks (DC)

The master designates a slave as the reference clock then adjusts the clocks of other slaves so that they operate in-sync. Cabling and network delays are compensated for. Current, velocity, and position loops in the drives are all synchronized within nanoseconds of each other. Jitter in the real-time kernel will not affect the slave synchronization as long as it does not exceed the update rate of the cyclic data and skip one data cycle, falling into the next.

Control System Timing and Process Data

With the network wired, DC configured, the master running, and all the slaves synchronized, the foundation has been laid to do some real motion control. Moving motors in CANopen was commonly done with the "profile" modes for position, velocity, and current. With these modes, parameters describing the motion are first configured. When bit 4 of the Control Word 0x6040 is toggled the drive starts to produce the motion without any further commands from the master. Completion of the profile move is shown by the status of bits in the Status Word 0x6041.

3.7 EtherCAT Data

Turn off the EtherCAT master and unplug all of the slaves. What's left is the network, and by itself, it does *nothing!* It's a railroad without trains and stations. And when it connects a master to slaves, it only carries one thing: *data*. Although the volume of data it can handle is unlimited, the types of data are few:

- • Process (Cyclic) data: transported by PDOs
- Mailbox (Acyclic) data: transported by SDOs
- FoE (File access over EtherCAT) Download firmware and upload drive configuration

Fixed PDOs

First, the bad news: *Fixed* means that the user can't change them.

Next, the good news: *Fixed* means they are saved to the CPU flash memory and are optimized for speed. They take less CPU time to execute, leaving more time for other tasks.

Receive and Transmit PDOs, relatively speaking...

From this it is clear that transmit & receive must always be discussed in the context of the producer and/or the consumer of the data.

<u>Master</u>	↔	<u>Slave</u>	<u>Types of Data</u>
Transmit	→	Receive	Control word, target position/velocity/torque, torque/velocity offset
Receive	←	Transmit	Status word, actual position/velocity/torque, position (following) error

Fixed RxPDOs

For CSP (Cyclic Synchronous Position) 0x6060 Mode of Operation = 8:

Receive PDO 4: 0x1700
 0x6040 Control Word
 0x607A Profile Target position
 0x60B1 Velocity Offset
 0x60B2 Torque Offset

For CSV (Cyclic Synchronous Velocity) 0x6060 Mode of Operation = 9:

Receive PDO 5: 0x1701
 0x6040 Control Word
 0x60FF Target Velocity
 0x60B2 Torque Offset

For CST (Cyclic Synchronous Torque) 0x6060 Mode of Operation = 10:

Receive PDO 6: 0x1702
 0x6040 Control Word
 0x60FF Target Velocity
 0x60B2 Torque Offset

Fixed TxPDO

Transmit PDO 5: 0x1B00
 0x6041 Status Word
 0x6064 Actual Motor Position
 0x60F4 Position Loop Error (following-error)
 0x606F Actual Motor Velocity
 0x6077 Torque Actual Value

Not-Fixed, or User Programmable PDOs

These are only used when the user defines their contents. They run slower and take more CPU time than the fixed PDO. This should be kept in mind when defining their contents, keeping the amount of data moved to the minimum required for tasks. Contents of these PDOs are not linked to any mode of operation as are the fixed PDOs.

Un-Fixed RxPDOs

Receive PDO 0: 0x1600
Receive PDO 1: 0x1601
Receive PDO 2: 0x1602
Receive PDO 3: 0x1603

Un-Fixed TxPDOs

Transmit PDO 1: 0x1A00
Transmit PDO 2: 0x1A01
Transmit PDO 3: 0x1A02
Transmit PDO 4: 0x1A03

3.8 EtherCAT System Architectures

Common in this context means architectures that are support *in common* by a number of masters. That is, their architectures have similar features and implementation. In the graphics below, Beckhoff *TwinCAT* software is shown as the master because it has features that incorporate all the ingredients of an EtherCAT motion control system.

Masters that Use ESI Files

Masters in this category share the common ability to ingest ESI files, scan the network, generate the network topology, and configure startup and cyclic commands. They may or may not have NC or PLC components. The example below used TwinCAT as the master because it uses ESI files and is fully-featured.

Network setup follows a sequence shown in the graphic below. Not shown is the basic physical connections and configuration of the servo/stepper drives for EtherCAT control.

1. The Master ingests ESI files after start-up
2. Scanning the network, the ESI file data is used to identify EtherCAT slaves and add them to the virtual network shown in the folder tree of the TwinCAT System Manager.
3. Based on the default Mode of Operation in the ESI file, NC controllers are linked to the drives. SDO, PDO, and DC settings are made between NC and drives. The entire configuration can be saved to a .TSM file.

At this point the system can be activated (TSM settings downloaded to the RT kernel) and the system can be started in RUN mode. Basic motion control is possible from the NC controllers, but no PLC programs exist at this time. The user must then create these to produce the overall machine control system for a given application.

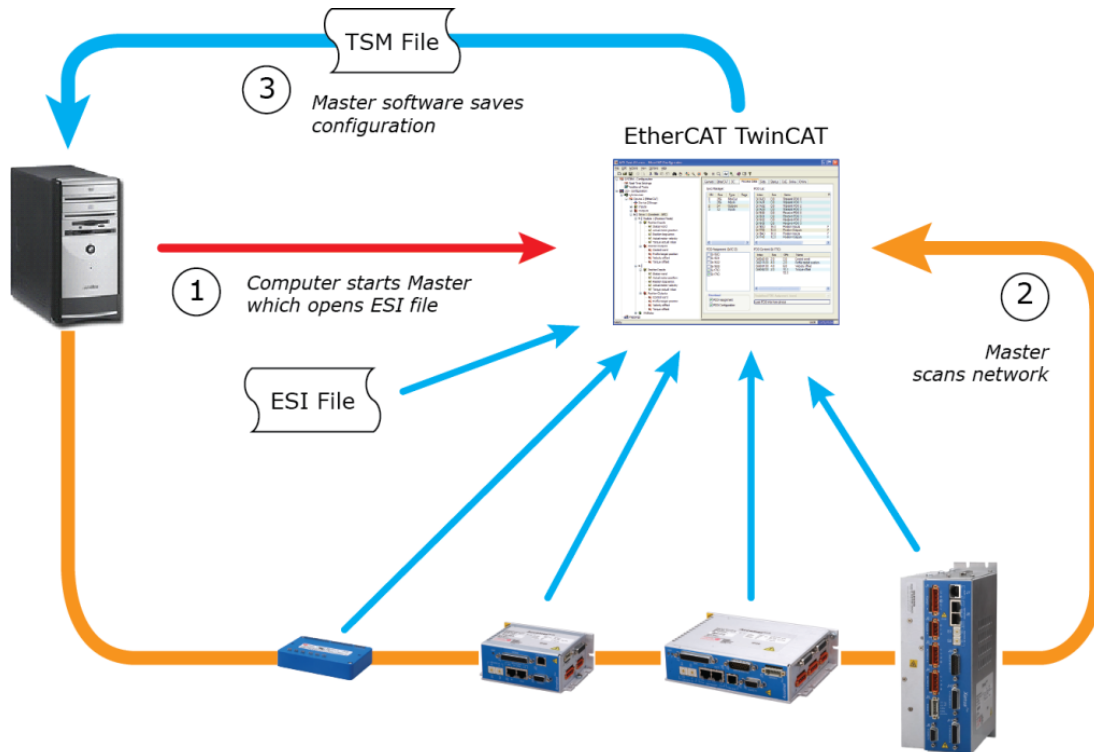

Masters That Don't Use ESI Files

The feature set of these masters may vary, but all require ENI files that provide all of the network information. Network setup follows a sequence shown in the graphic below. Not shown is the basic physical connections and configuration of the servo/stepper drives for EtherCAT control.

Step 1

1. The Configurator program ingests ESI files after start-up
2. Scanning the network, the ESI file data is used to identify EtherCAT slaves and add them to the virtual network shown in the folder tree of the Configurator
3. The Configurator outputs an ENI (EtherCAT Network Information) file.

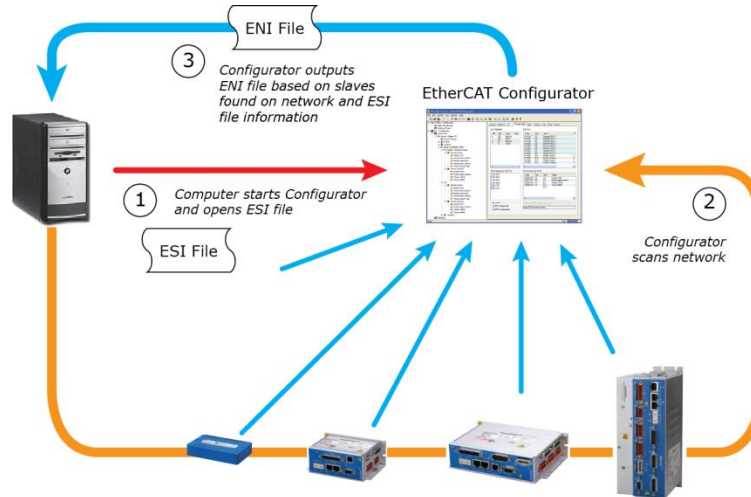

Step 2

Using the information from the ENI file, the master makes settings for each drive and then saves the entire configuration as a Master (TSM in TwinCAT) file that contains all of the control system information.

4. The Master ingests the ENI file
5. Settings are made for each slave on the network
6. The Master outputs a TSM (Master configuration) file and activates the configuration.

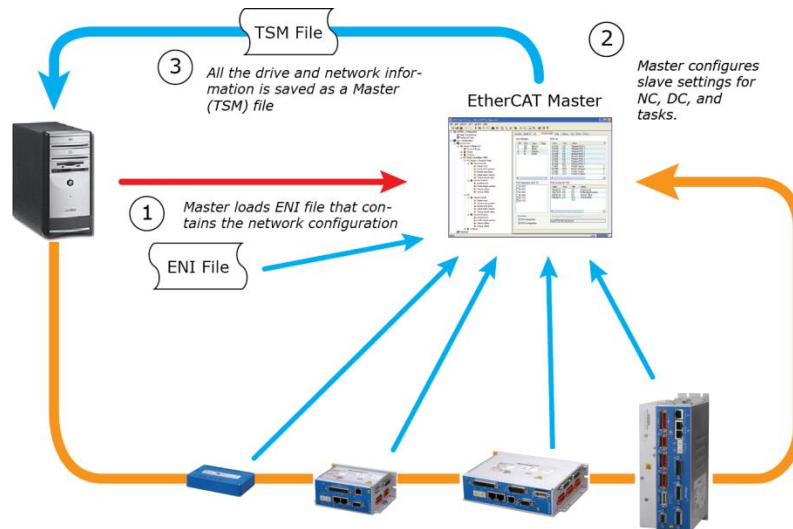

4 SETTING UP FOR ETHERCAT

AC Drive EtherCAT Connectors

XEL



XE2



DC Drive EtherCAT Connectors

BEL, TEL

BE2, TE2



4.1 EtherCAT Cabling

The physical layer of an EtherCAT network is 100BASE-TX which uses Cat 5 (or higher) cabling. The maximum length between nodes on the network is 100 metres (328 ft.) The EtherCAT connectors on the drives have IN and OUT ports which should be used when cabling runs through a drive. These are the same cables and RJ-45 connectors that are used on CANOpen drives. However, EtherCAT network cabling does not require a terminating resistor on the last drive in the network. The PHY (PHYSICAL interface) of the last drive in the network will automatically route the data from the incoming pair of wires to the returning pair.

Keep EtherCAT cables separated from motor cables that connect to the PWM outputs of the drives. This will eliminate noise coupling from motor cables into the network cabling.

4.2 Indicators: EtherCAT LEDs

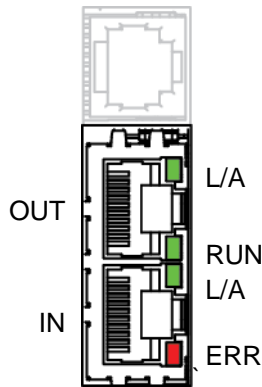

L/A A green LED indicates the state of the EtherCAT network:

LED	Link	Activity	Condition
ON	Yes	No	Port Open
Flickering	Yes	Yes	Port Open with activity
Off	No	(N/A)	Port Closed

RUN Green: Shows the state of the ESM (EtherCAT State Machine)

Off	=	Init
Blinking	=	Pre-operational
Single-flash	=	Safe-operational
On	=	Operational

ERR Red: Shows errors such as watchdog timeouts and unsolicited state changes in the XE2 due to local errors.

Off	=	EtherCAT communications are working correctly
Blinking	=	Invalid configuration, general configuration error
Single Flash	=	Local error, slave has changed EtherCAT state autonomously
Double Flash	=	PDO or EtherCAT watchdog timeout, or an application watchdog timeout has occurred

4.3 Device ID Switches & Station Alias

In an EtherCAT network, slaves are automatically assigned fixed addresses based on their position on the bus. But when the device must have a positive identification that is independent of cabling, a Device ID is needed. In the Plus Panel drives, this is provided by two 16-position rotary switches with hexadecimal encoding. These can set the Device ID of the drive from 0x01~0xFF (1~255 decimal). The chart shows the decimal values of the hex settings of each switch.

Example 1: Find the switch settings for decimal Device ID 52:

- 1) Find the highest number under S1 that is less than 52 and set S1 to the hex value in the same row: $48 < 52$ and $64 > 52$, so $S1 = 48 = \text{Hex } 3$
- 2) Subtract 48 from the desired Device ID to get the decimal value of switch S2 and set S2 to the Hex value in the same row: $S2 = (52 - 48) = 4 = \text{Hex } 4$

Device ID

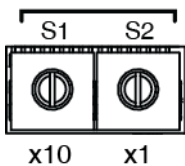

CME2 -> Amplifier -> Network Configuration

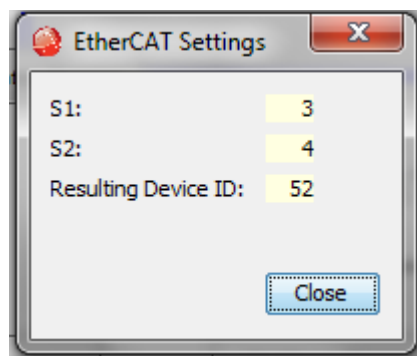

	S1	S2
HEX	DECIMAL	
0	0	0
1	16	1
2	32	2
3	48	3
4	64	4
5	80	5
6	96	6
7	112	7
8	128	8
9	144	9
A	160	10
B	176	11
C	192	12
D	208	13
E	224	14
F	240	15

EtherCAT Device ID Switch Decimal Values

4.4 Drive Axis Indicators

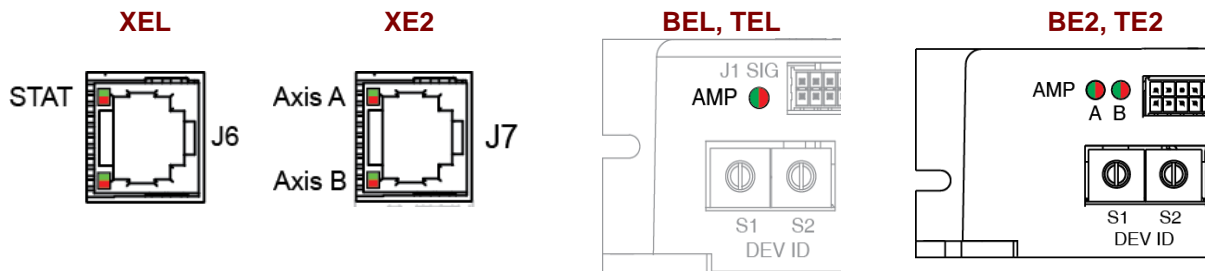

A bi-color LED gives the state of each axis. Colors do not alternate, and can be solid ON or blinking. When multiple conditions occur, only the top-most condition will be displayed. When that condition is cleared the next one below will be shown.

- | | | |
|--------------------------|---|--|
| 1) Red/Blinking | = | Latching fault. Operation will not resume until drive is Reset. |
| 2) Red/Solid | = | Transient fault condition. Drive will resume operation when the condition causing the fault is removed. |
| 3) Green/Double-Blinking | = | STO circuit active, drive outputs are Safe-Torque-Off |
| 4) Green/Slow-Blinking | = | Drive OK but NOT-enabled. Will run when enabled. |
| 5) Green/Fast-Blinking | = | Positive or Negative limit switch active. Drive will only move in direction not inhibited by limit switch. |
| 7) Green/Solid | = | Drive OK and enabled. Will run in response to reference inputs or EtherCAT commands. |

Latching Faults

Defaults

- Short circuit (Internal or external)
- Drive over-temperature
- Motor over-temperature
- Feedback Error
- Following Error

Optional (programmable)

- Over-voltage
- Under-voltage
- Motor Phasing Error
- Command Input Fault

4.5 Drive Wiring

Before the drive can operate under EtherCAT control, the other non-network connections must be made. Here is a checklist for these, details can be found in the datasheets for the particular drives:

AC-Powered drives:

Connect to mains power with provisions for on/off control, protection, filtering, and surge-protection devices (SPD)

DC-Powered drives:

Connect to transformer-isolated DC power sources for +HV and optionally HV-Aux.

General wiring:

Wire inputs to any limit or home switches, and any control system outputs that could operate as Enable or other control signals.

Wire outputs to motor brakes (if used) or other devices to be controlled.

Connect motors and feedback devices. Route feedback cables apart from motor power cables to reduce coupling of PWM outputs into feedback signals.

IMPORTANT:

Provide either a hardware Enable signal from the control system, or an EMO (Emergency Off) mushroom switch for mains or DC power to the drives. It is very important to have the ability to prevent the drive from producing torque in a motor without using the network which can fail, either due to software control or cabling, and lose the ability to disable the drive. In addition to these measures, the STO function can provide the capability to stop torque production in the motor.

When wiring is complete, launch CME2 and configure the drive for EtherCAT control.

5 CONFIGURING DRIVES FOR ETHERCAT

5.1 Serial RS-232 Connections

Serial communication is recommended for EtherCAT operation because CME2 and the EtherCAT master can not share the EtherCAT port at the same time. With serial communications, CME2 can access the drive before the network is in operation. Two types of Serial Cables Kits are available that plug into a computer's COM port (Dsub-9M) and connect to servo drive:

Cable Kit For Drive

- SER-CK XEL, XE2, BE2, TE2
- BEL-SK BEL
- TEL-SK TEL

The BEL-SK and TEL-SK are electrically identical and will work with either BEL or TEL drives.

Serial Connection: Xenus AC Powered Drives

The SER-CK Serial Cable kit will accept the Dsub-9M connector that is commonly used for the COM1(2,3,4) port on a computer and adapts it to a modular cable that plugs into the Serial port of the Xenus drives. Mains power is not needed for the network to operate, so the +24 Vdc supplied to the Xenus will power the serial port and network operation.

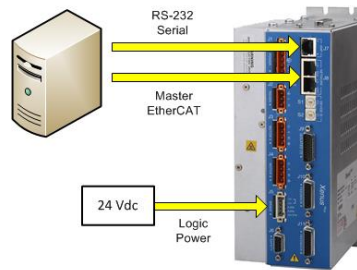

Serial Connection: Accelnet & Stepnet DC Powered Drives

BE2 & TE2 2-Axis drives have an RJ-11 modular socket for the serial data port. It uses the SER-CK Serial Cable Kit to connect to a computer with a Dsub-9M connector for the COM1(2,3,4) port.

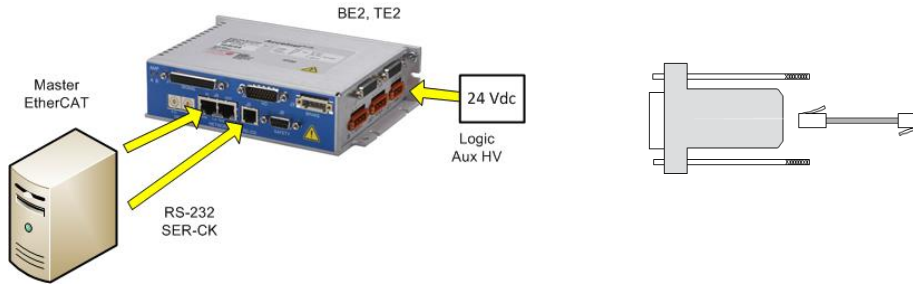

BEL & TEL 1-axis drives also have an RJ-11 modular socket for the serial data port, and use the SER-CK.

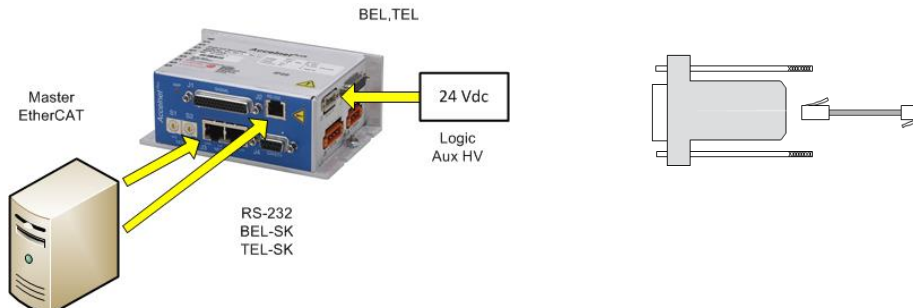

EtherCAT Connections

With serial communications, it is not possible for CME2 to connect to a drive using a COM port that is in use by another device. But, when EtherCAT is used for the CME2 connection, the NIC (Network Interface Card) is available for CME2 even though the EtherCAT master program is running and connected to the drive.

Because CME2 can write to and alter drive parameters that may be in use by the master, it is recommended that CME2 does not be used over EtherCAT when the master is in control.

Before connecting CME2 to a drive over EtherCAT, ensure that the EtherCAT master is disabled. The graphic below illustrates the concept. The physical switch shown is not necessary, but the switching off of one task while the other one is on is represented here as a switch.

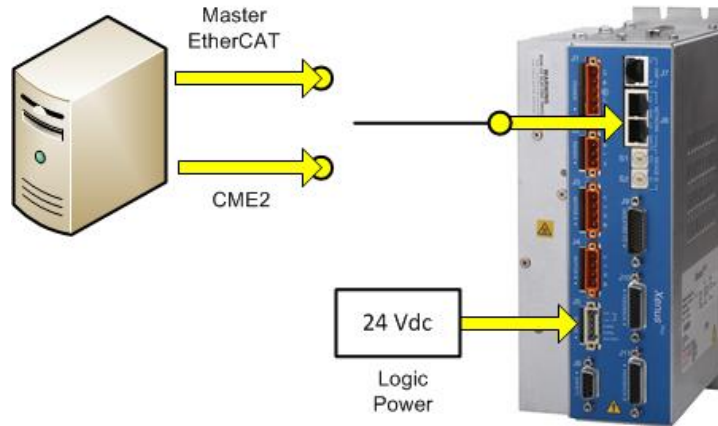

5.2 CME2 Installation for EtherCAT

Download CME2

Open your web browser and navigate to the Copley Controls web-site: <http://www.copleycontrols.com>
From the Menu bar, go to the Downloads page, Software Releases and select CME2:

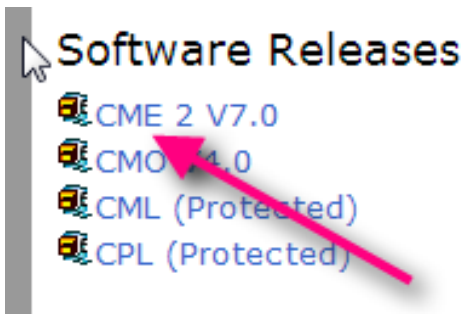

Save to your computer, unZip the file, and launch Setup.exe

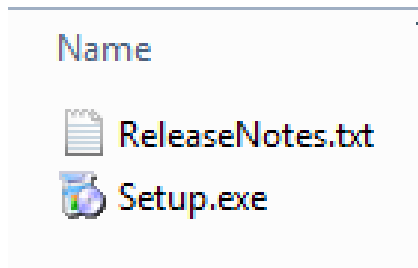

Configure the drive for EtherCAT operation

This is the Home page of CME2

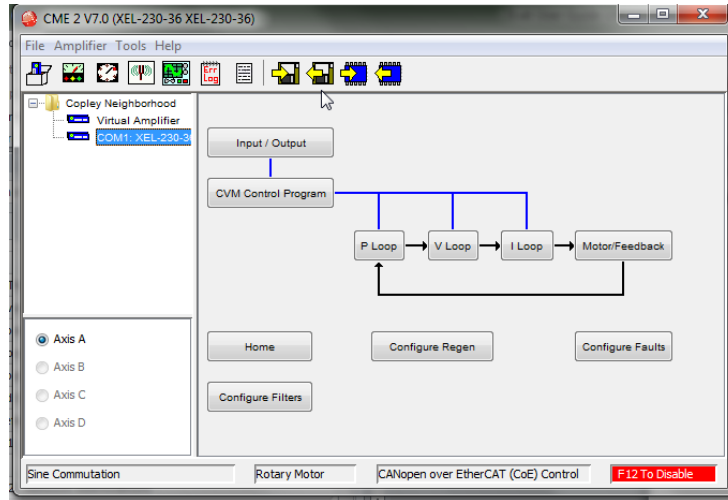

Go to Amplifier > Basic Setup (menu bar) or click the jack-in-the-box icon:

Click [Change Settings] to begin Pick Motor Family and Motor Type

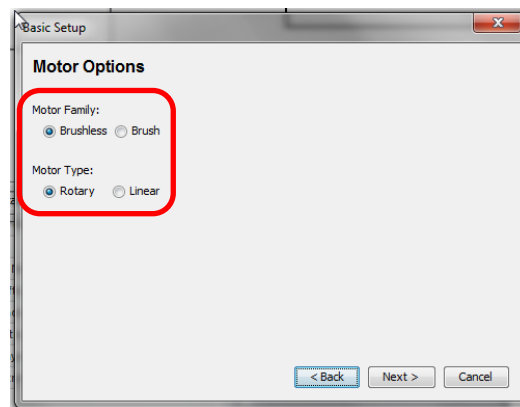
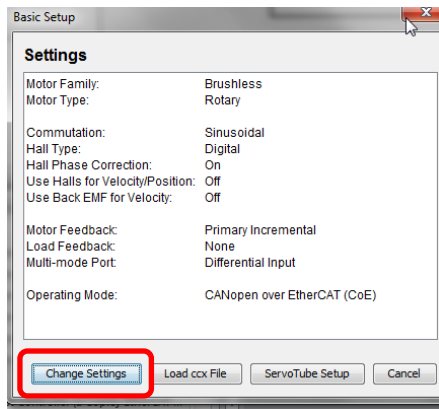

Feedback Options

Hall Type, Motor Feedback typically

Select Position for Operating Mode (CoE)

Operating Mode: Position is the default

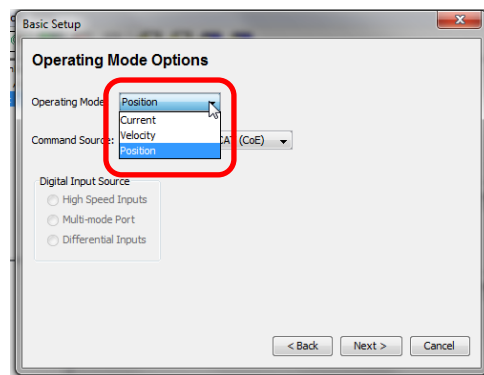
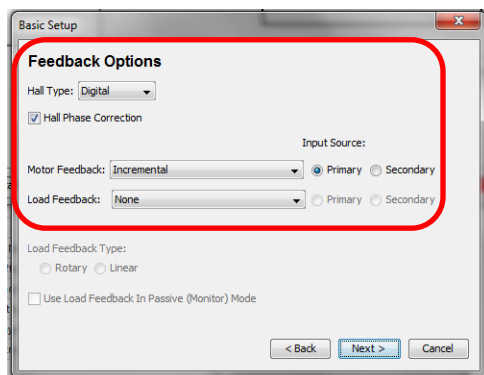

Command Source: for EtherCAT, Miscellaneous Option
use CANopen over EtherCAT (CoE) Default selections are OK for most apps

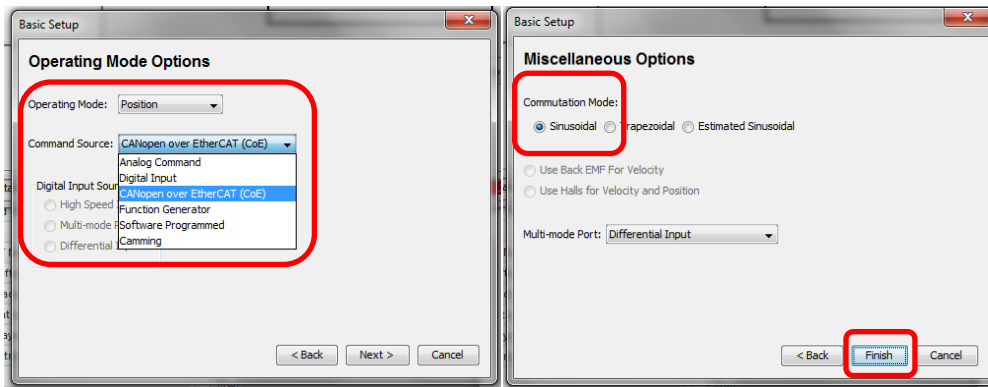

Click [Finish] to exit Basic Setup, and [OK] to save to flash

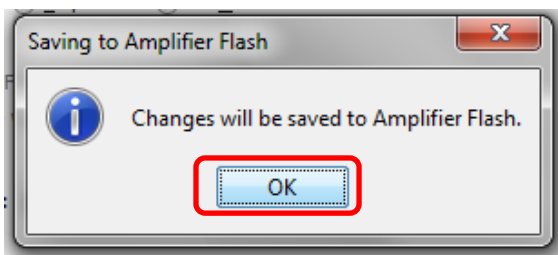

This will return you to the CME2 main page.
Click to open the [Motor/Feedback] box.

Motor Set Up

When Basic Setup completes, open the Motor/Feedback block on the CME2 main screen.
Fill in the motor data, followed by the Feedback and Brake (if used) tabs data.

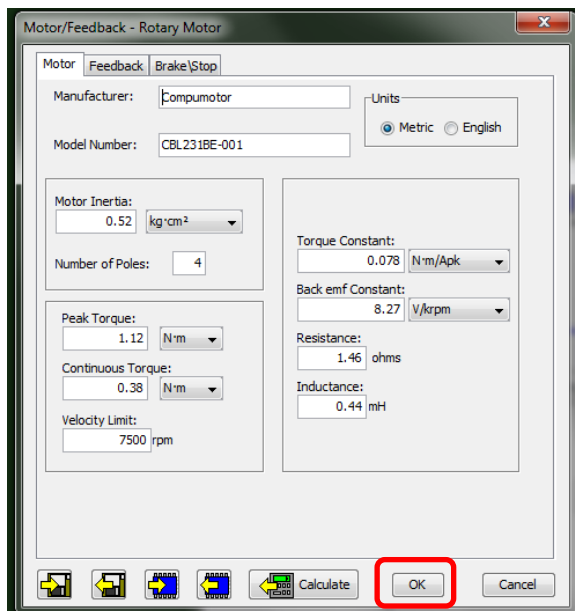

Click [OK] to the Calculate question and this will be followed by the screen below.
Click [OK] to exit to the main page.

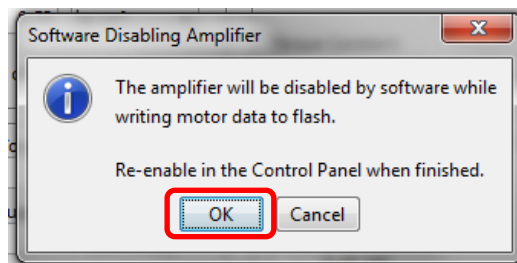

Proceed to **Amplifier > Auto Phase** to configure the motor commutation. Then, use the CME2 scope to tune the Velocity and then Position loops. Refer to the *CME2 User Guide* for details on these operations. This can be found either in the CME2 installation folder, or on the Copley Controls web-site: http://www.copleycontrols.com/Motion/pdf/CME2_User_Guide.pdf

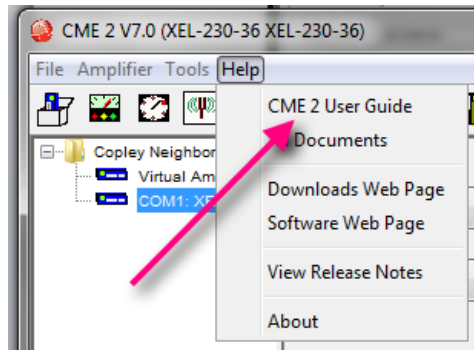

Enable the drive for EtherCAT control

When the motor is set up and tuned well for position mode operation, open the Control Panel. If it has been "software disabled" by pressing the **[Disable]** button it will look like this:

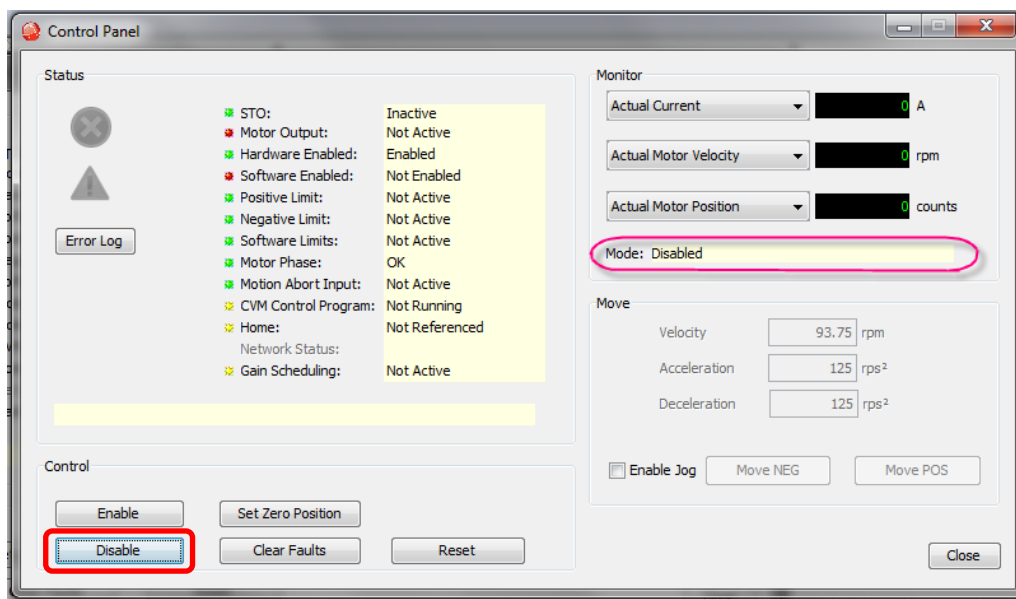

To operate using EtherCAT, it must first be “software enabled” by the CME2 software. Press the **[Enable]** button on the Control Panel and the screen should look like this:

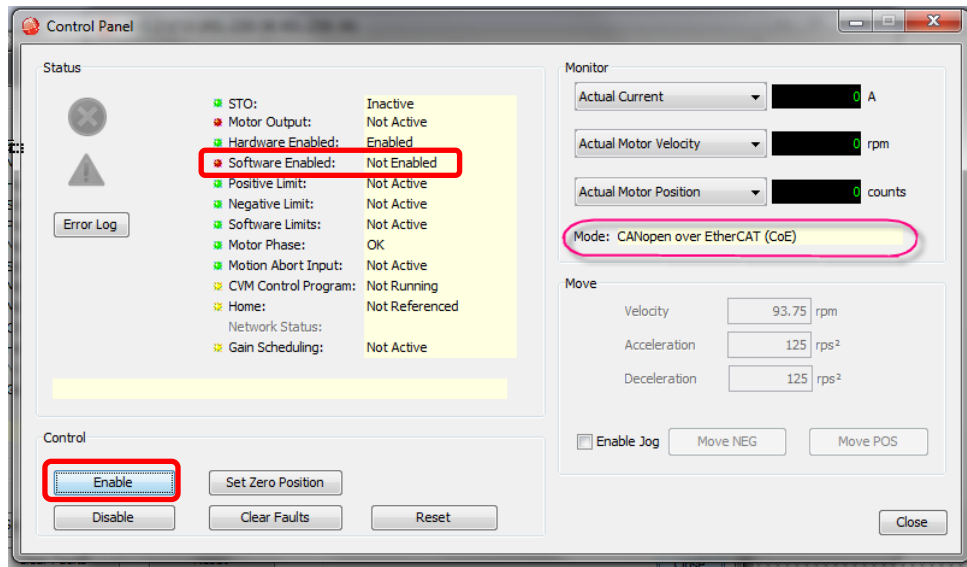

IMPORTANT: The operating mode is now CoE and the Software Enabled “led” on the Control Panel is referring to the EtherCAT master software that will be controlling the drive over the network. Because the CME2 configuration typically precedes the EtherCAT master software setup, the drive will be not be software-enabled by the EtherCAT master and the result will be red LEDs for both the Software Enabled and Motor Output indicating that these items are OFF.

Download ESI (EtherCAT Slave Information) Files



Commonly referred to as XML files, which describes the format of the file but not its contents. These files are found on the Copley web-site: <http://www.copleycontrols.com/Motion/zip/ecatxml.zip>



Click the EtherCAT link and download them to your desktop, or other folder for now.



Unzip the *ecatxml.zip* file and it will produce a folder named *ecatxml* with these contents:

 flat	3/5/2014 1:41 PM	File folder	
 slots	3/5/2014 1:41 PM	File folder	
 readme.txt	3/5/2014 1:41 PM	Text Document	1 KB

This is the contents of the readme.txt file:

Copley Controls now provides ESI files for it's EtherCAT drives in two different formats.

The folder named 'slots' provides ESI files which use the 'slots and modules' format for describing the drive's functionality. This format allows multi-axis drives to be described in a way that makes setting them up very easy in EtherCAT masters which support the format. These files are preferred for use with TwinCAT, and other masters which support slots and modules.

The folder named 'flat' provides ESI files which do not use slots and modules. These files should be used for masters which do not yet support the more modern format.











Only one set of files should be installed at a time. Most EtherCAT masters will complain if they see multiple ESI files for the same device type.

The *slots* folder contains ESI files that are for EtherCAT masters that support the MDP (Modular Device Profile) that is defined in the document ETG 5001. Use the files in the *slots* folder for TwinCAT 2 & TwinCAT 3.

The *flat* folder contains ESI files that are for masters that do not support the MDP, such as the Delta Tau PMAC controllers.

Select all of the *slots* ESI files and Control-C to copy them to the clipboard. Use Windows Explorer to navigate to this folder in the TwinCAT installation:

C:\TwinCAT\3.1\Config\Io\EtherCAT. Click in this folder and Paste (Control-V) the ESI files here.

Name ^	Date modified	Type	Size
 Copley_AE2_1.38.xml	3/5/2014 1:41 PM	XML Document	458 KB
 Copley_AEM_1.38.xml	3/5/2014 1:41 PM	XML Document	380 KB
 Copley_AEP_3.34.xml	3/5/2014 1:41 PM	XML Document	253 KB
 Copley_BE2_1.68.xml	3/5/2014 1:41 PM	XML Document	481 KB
 Copley_BEL_1.68.xml	3/5/2014 1:41 PM	XML Document	394 KB
 Copley_SE2_1.38.xml	3/5/2014 1:41 PM	XML Document	458 KB
 Copley_SEM_1.38.xml	3/5/2014 1:41 PM	XML Document	380 KB
 Copley_TE2_1.68.xml	3/5/2014 1:41 PM	XML Document	481 KB
 Copley_TEL_1.68.xml	3/5/2014 1:41 PM	XML Document	394 KB
 Copley_XE2_1.70.xml	3/5/2014 1:41 PM	XML Document	481 KB
 Copley_XEL_1.60.xml	3/5/2014 1:41 PM	XML Document	387 KB

IMPORTANT: ESI file installation must be complete before TwinCAT 3 is launched. TwinCAT 3 will only identify slaves on the network that have ESI files in the C:\TwinCAT\3.1\Config\Io\EtherCAT folder which it scans ONCE after launching.

6 ETHERCAT QUICK STARTS

6.1 Beckhoff TwinCAT 3

Introduction

This document provides information on commissioning Copley Controls EtherCAT servo drives using the TwinCAT3 EtherCAT master software. When these steps are followed, it should be possible to move a servo motor via a Copley Controls servo drive from an NC controller in TwinCAT3. For more advanced motion control it is necessary to consult the Beckhoff InfoSystem software for details. The first step is to download all of the software and data needed to produce a working TwinCAT 3 system.

TwinCAT3 Software

Find TwinCAT 3 on the Beckhoff web-site here: <http://www.beckhoff.com/>
 Navigate to *Download -> Software -> TwinCAT3*
 Click on *TE1xxx | Engineering*:

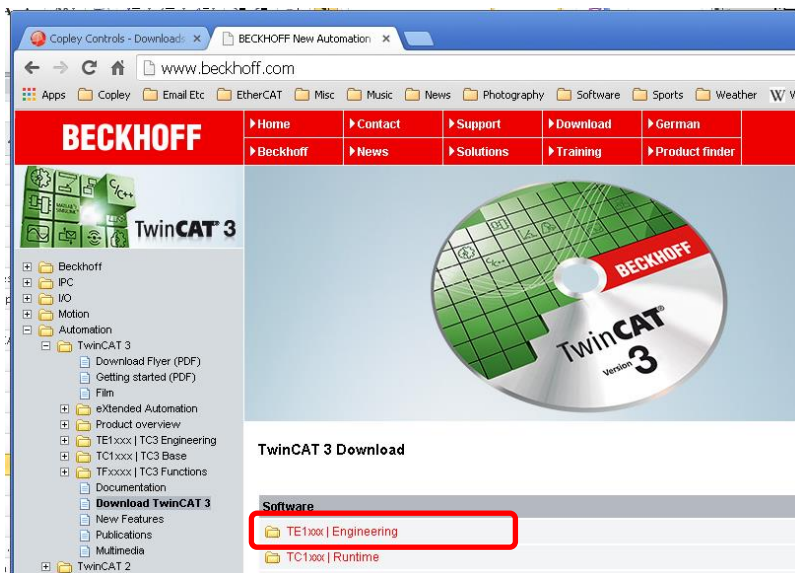

In the next screen, click on *TwinCAT 3.1 –eXtended Automation Engineering (XAE)*:

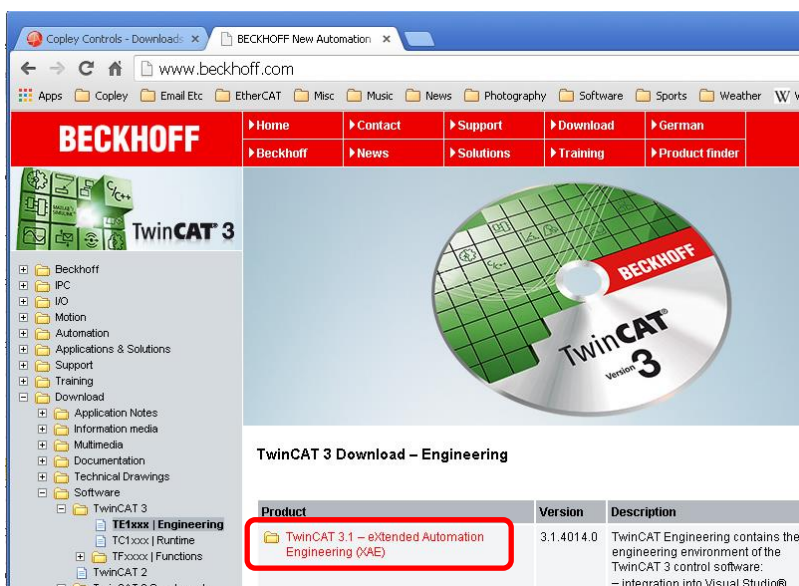

Now click on TC31-Full-Setup.3.1.4040.0
Then click Start Download:

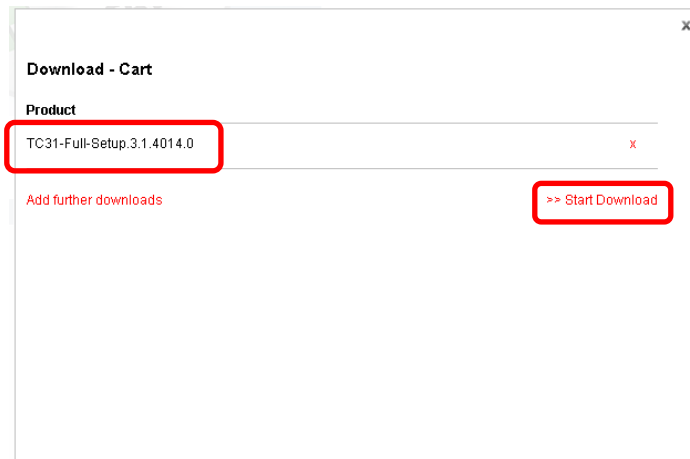

Download as a guest:

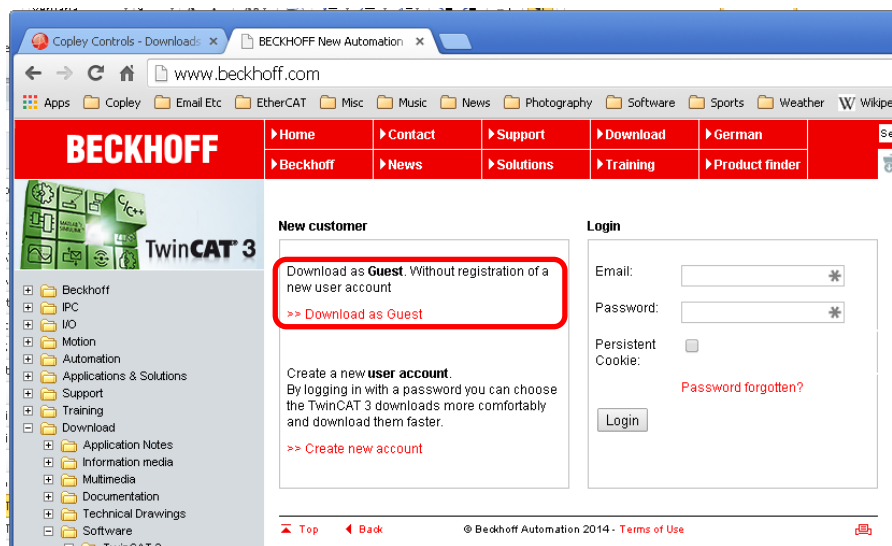

Using the *Download as Guest* link, A form will appear, so fill it out and click on *Register*. An email will be sent to the address you gave on the registration form.



Click on the links in the email to download the TwinCAT3 files for the TC31-Full-Setup software.
After un-zipping the downloads, open the install folder.

TC3-Full-Setup

Click on the TC31-Full-Setup file (the date numbers may vary) to begin installation.



Click Next to continue:

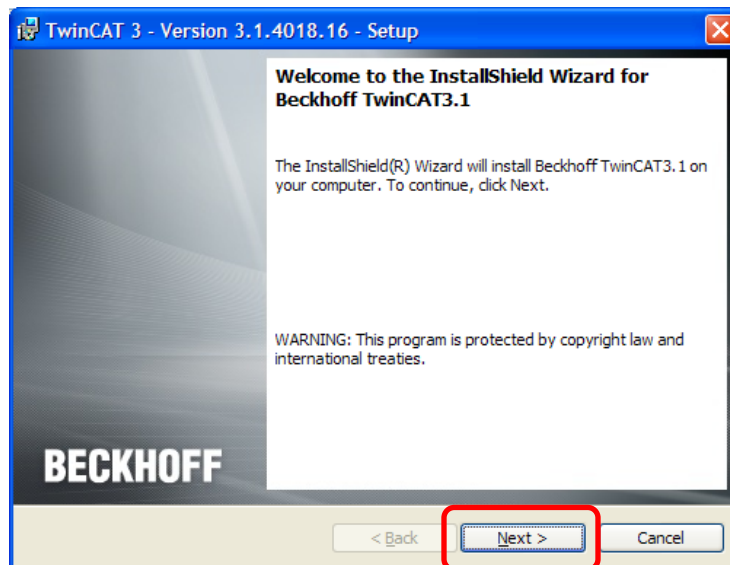

The Organization box must be used to continue:

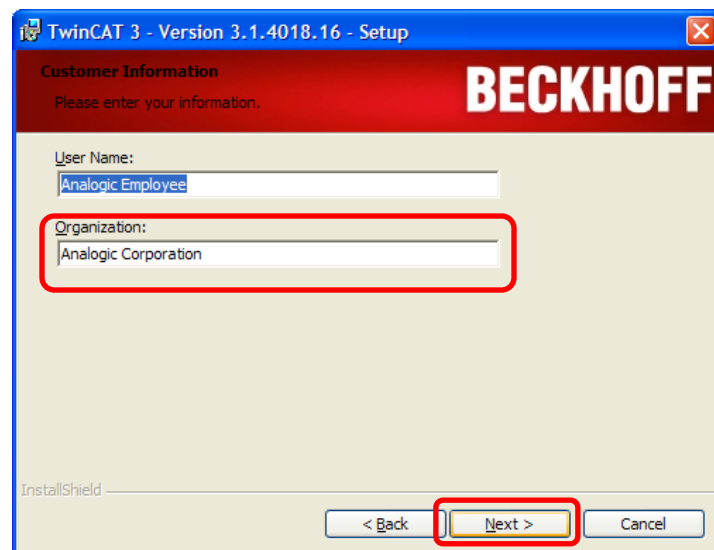

Click to select the Complete installation and click Next to continue::

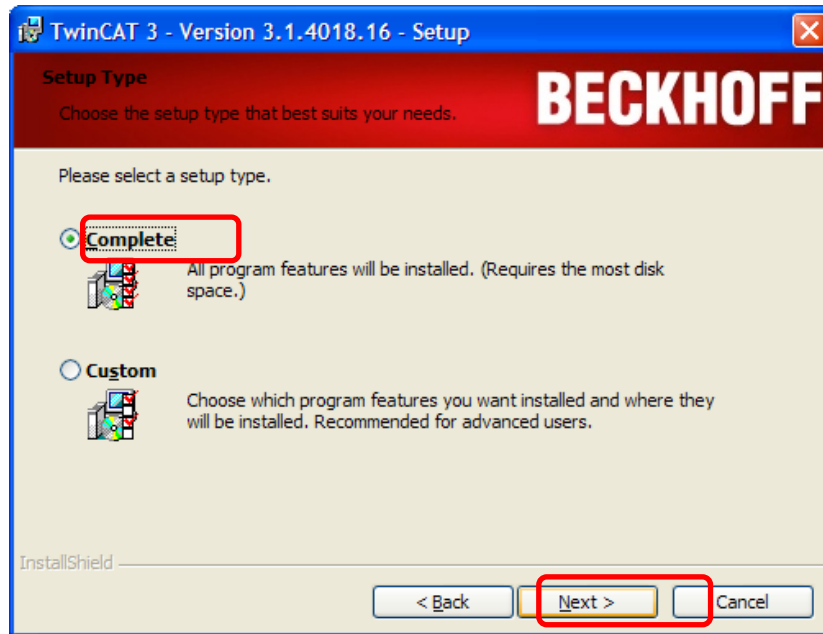

Click the box to add the TwinCAT XAE feature to the Visual Studio, and then Next to continue:

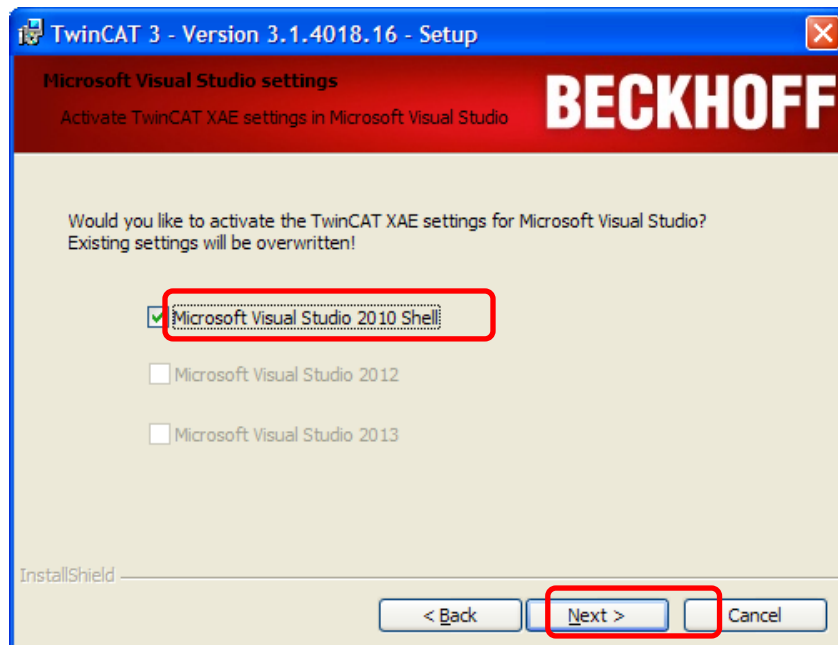

Now click Install to begin the installation:

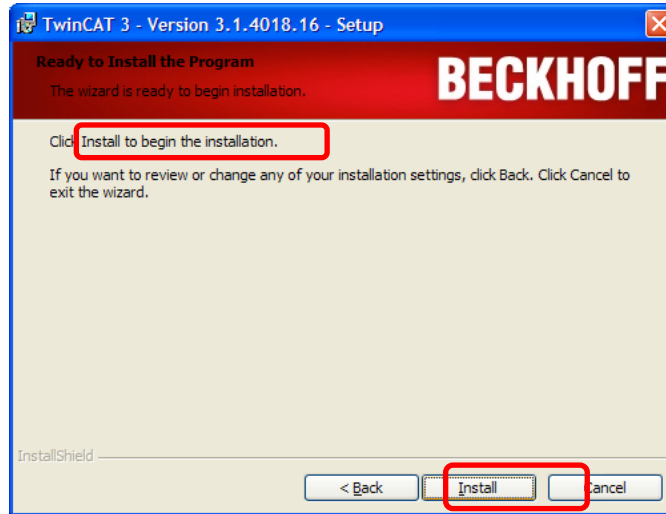

The progress bar appears while the installation is in process:

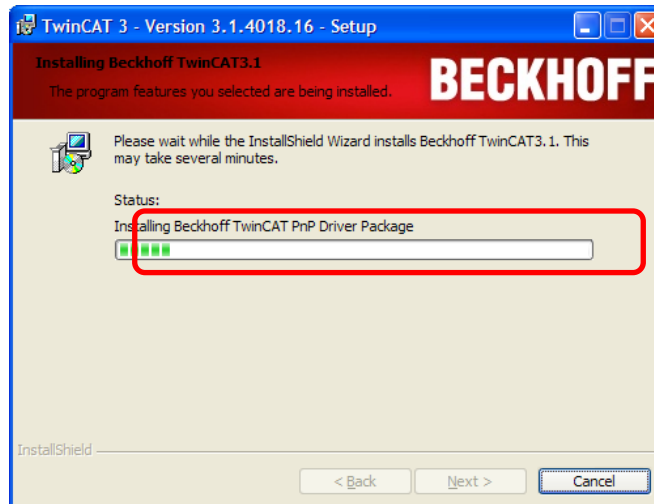

You will be prompted when the installation is complete, click Finish and Yes to restart in the next screen:

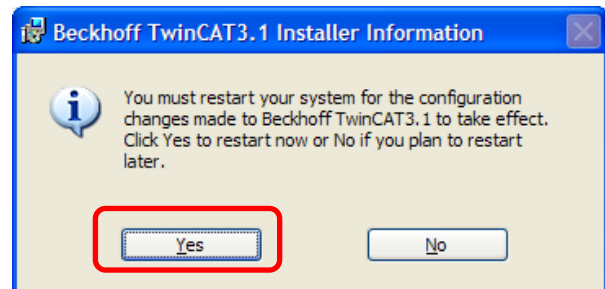
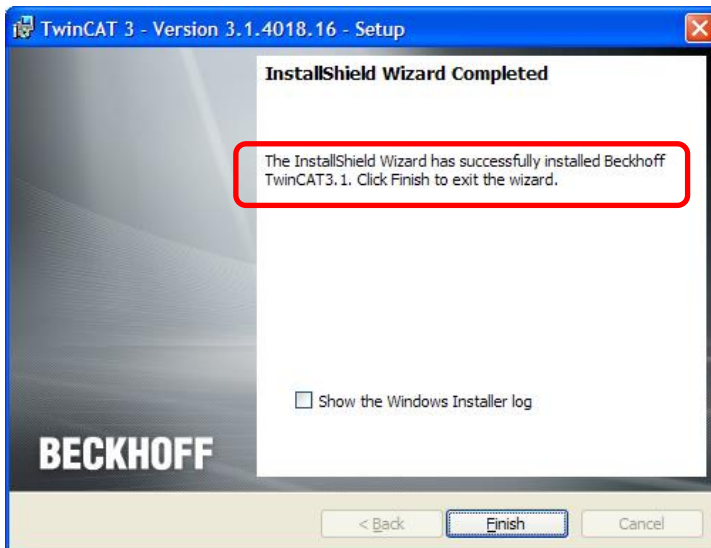

Install ESI Files

DO NOT LAUNCH TWINCAT3 BEFORE INSTALLING THE ESI FILES !

But if you have already opened TwinCAT 3, exit/close it now and proceed to the ESI file installation.

Go to the folder where the Copley ESI files were downloaded. Open the slots folder, select all of the files in the folder. Copy them and paste into this folder in the TwinCAT 3 installation:

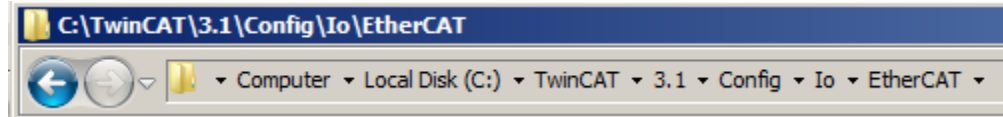

Confirm that TwinCAT 3 is the Active Runtime

TwinCAT 3 will install if TwinCAT 2 is already in the computer. It goes into the 3.1 folder under the C:\TwinCAT folder. After installation, TwinCAT 2 may appear as the active Runtime, but it is still possible to make TwinCAT 3 the active Runtime. With the TwinCAT 3 installation there is a file named TcSwitchRuntime which is a tool that will easily switch the runtime core between TwinCAT 3 and TwinCAT 2.

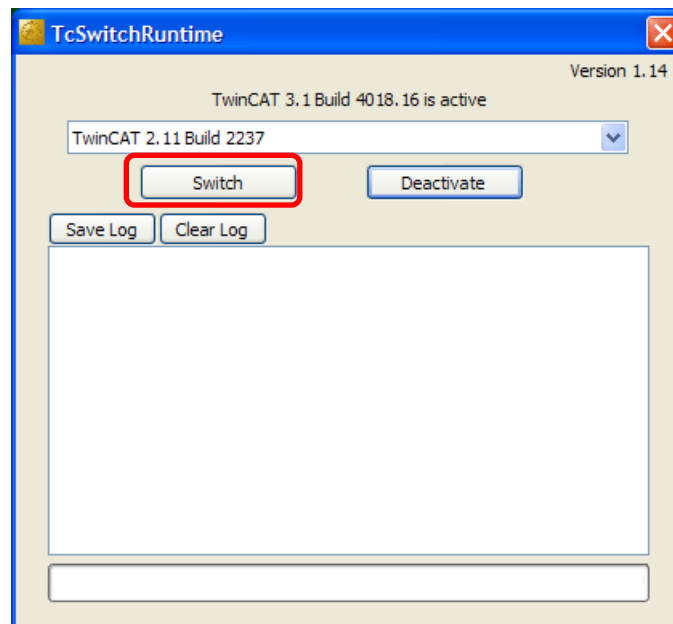

This screen shows that TwinCAT 3 is the active Runtime. But if the TcSwitchRuntime screen shows that TwinCAT 2.. is active, then click Switch and follow the steps to make TwinCAT 3 the active Runtime.

Assign an Ethernet Port on Your Computer to EtherCAT

EtherCAT should use a dedicated NIC (Network Interface Card) so that It does not share a port with other Ethernet traffic. For desktop computers, this can be a PCI card NIC which are commonly available and inexpensive. For laptops, it's best to use the built-in Ethernet port for EtherCAT and then use a PC card or wireless for general Ethernet activity. The built-in Ethernet port will generally run faster than an accessory port and works better for EtherCAT. In this example, *eth1* is used for EtherCAT and the other port is for general EtherCAT use.

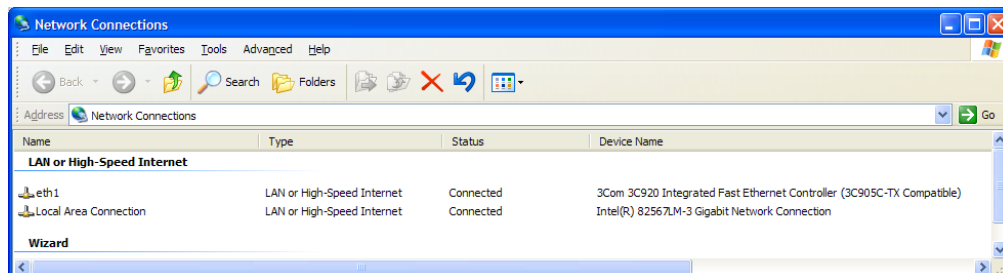

Running TwinCAT 3

Goto: Start Menu → All Programs → Beckhoff → TwinCAT3 → TwinCAT XAE (VS 2010)

First, the splash screen:



Then the TwinCAT3 home page. From here click on *New TwinCAT Project*:

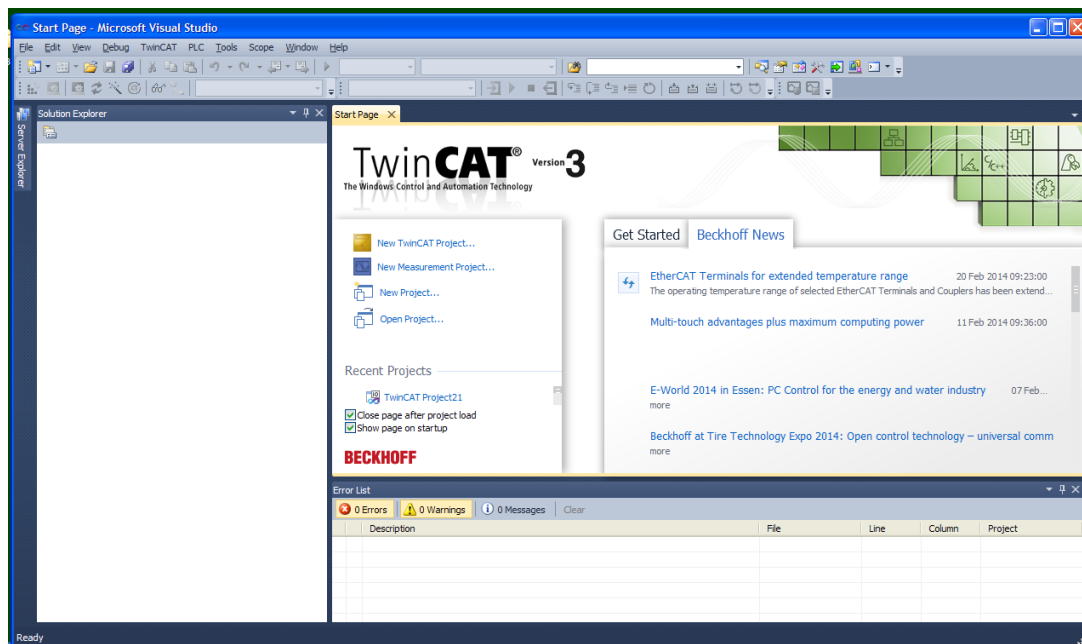

The New Project Screen

Because TwinCAT3 now uses *Microsoft Visual Studio* as the user interface, file organization follows those rules. A *Solution* contains items used to create a complete application which is composed of multiple *Projects*, and other supporting data.

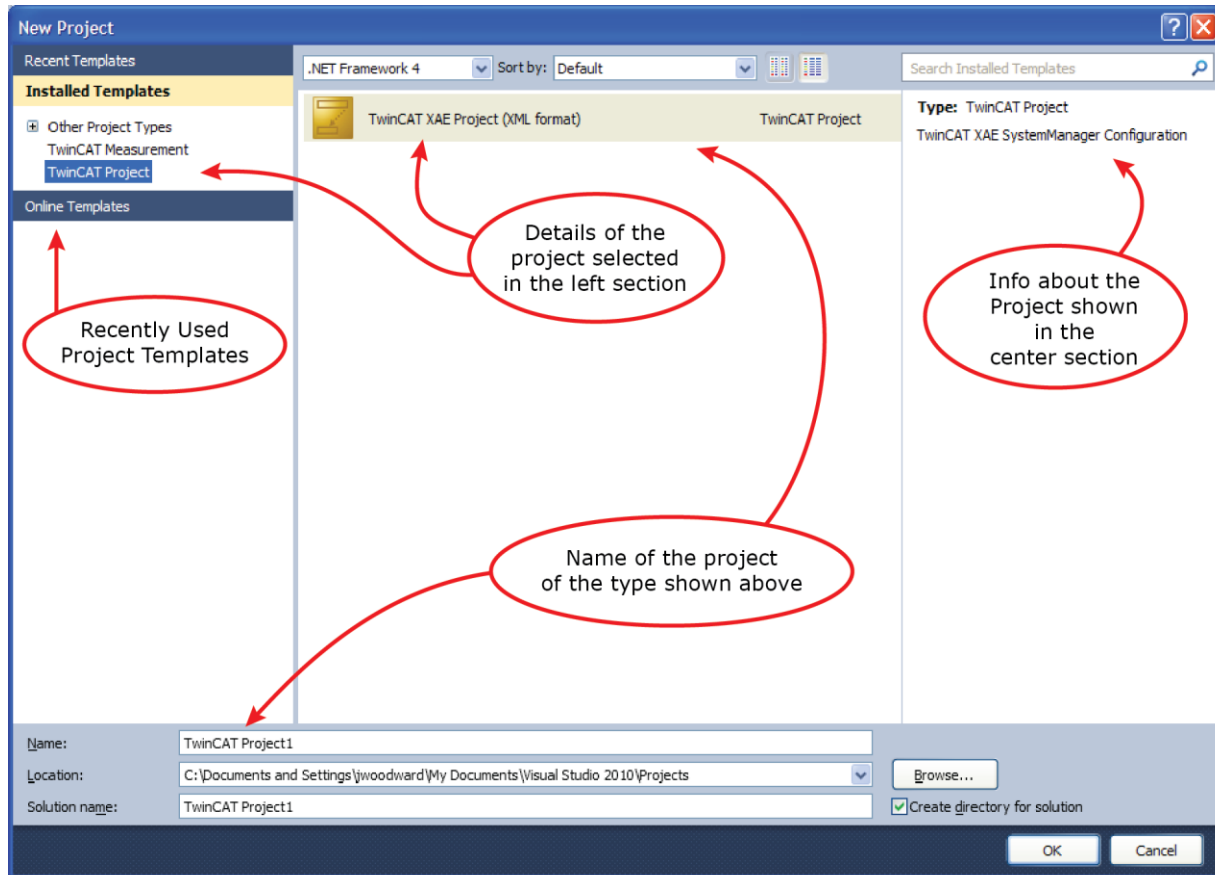

Click OK to go ahead with the default *TwinCAT Project1*, or use your own project name instead. Now we see the main page of what used to be the System Manager in TwinCAT 2. Click on the [+] I/O to expand that section.

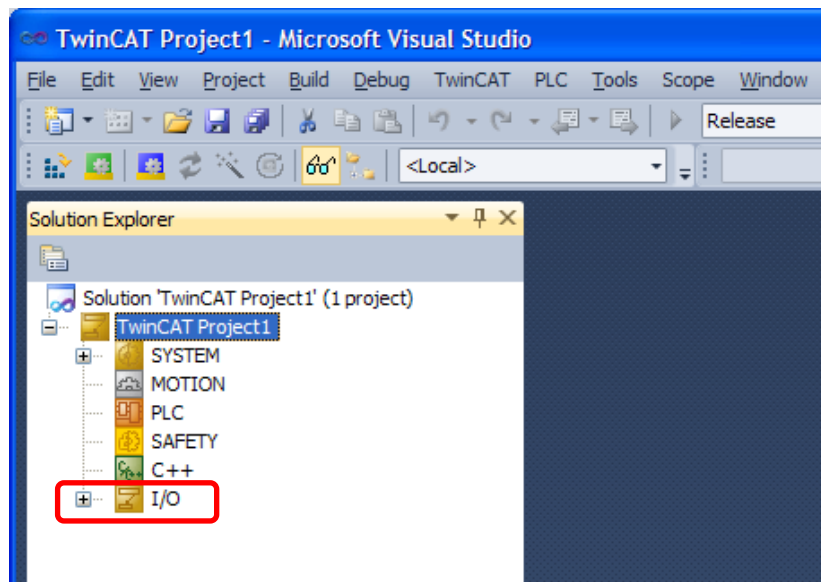

The I/O object opens up to this screen. Right-click on Devices, then click Scan on the pop-up:

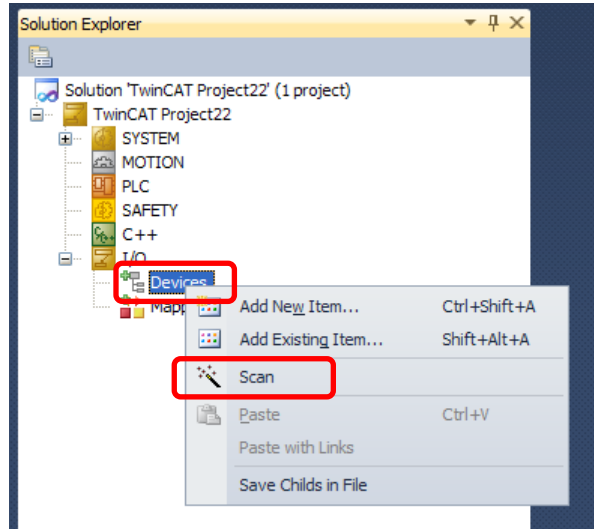

Click OK on the next screen, and TwinCAT 3 will start to scan the network for devices:

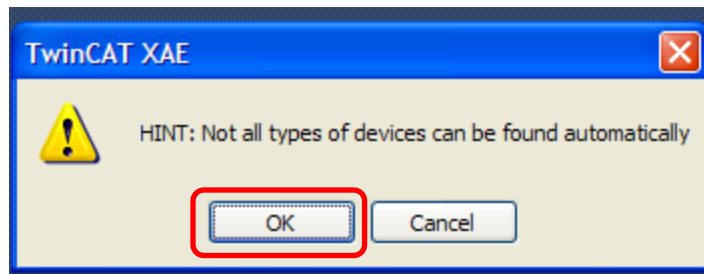

If the NIC is properly configured, it will show the EtherCAT attribute when it's found:

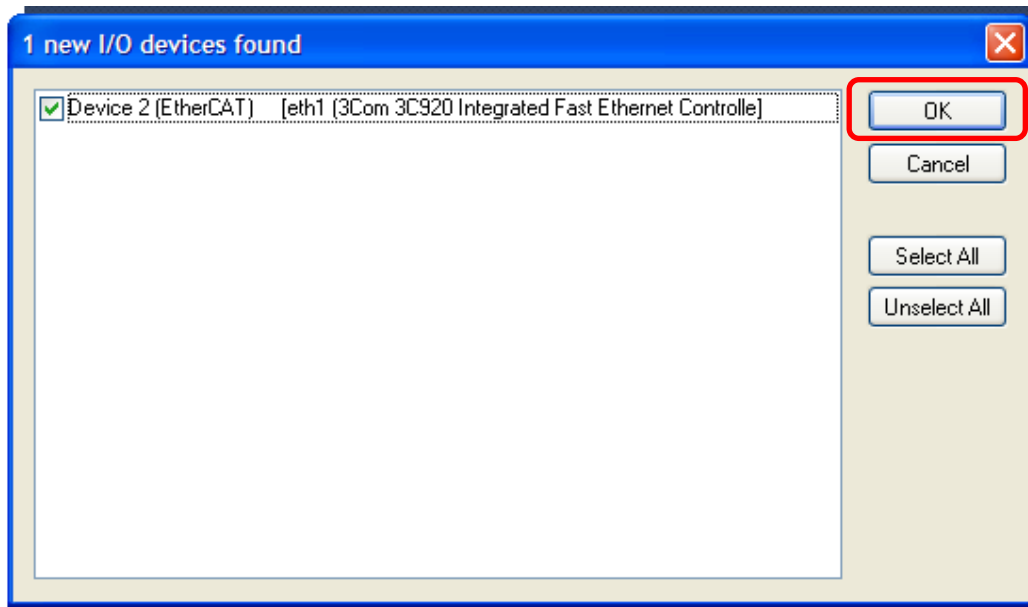

Click OK to continue...

With the NIC open to the EtherCAT network, the next step is to scan for "Boxes" (EtherCAT devices).

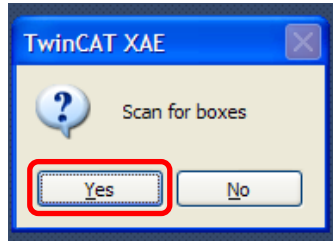

A Xenus XEL is found. TwinCAT 3 will automatically link this to an NC controller.

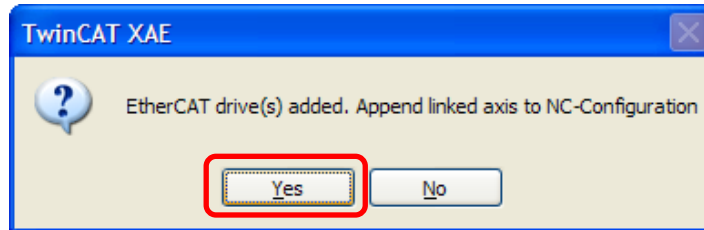

Click on the [+] at Drive 1 (Xenus Plus – XEL) to expand it. Then click [+] at Module 1, again [+] on Cyclic Position Inputs, then [+] on Cyclic Position Outputs. This will display the default inputs and outputs for Cyclic Sync Position mode.

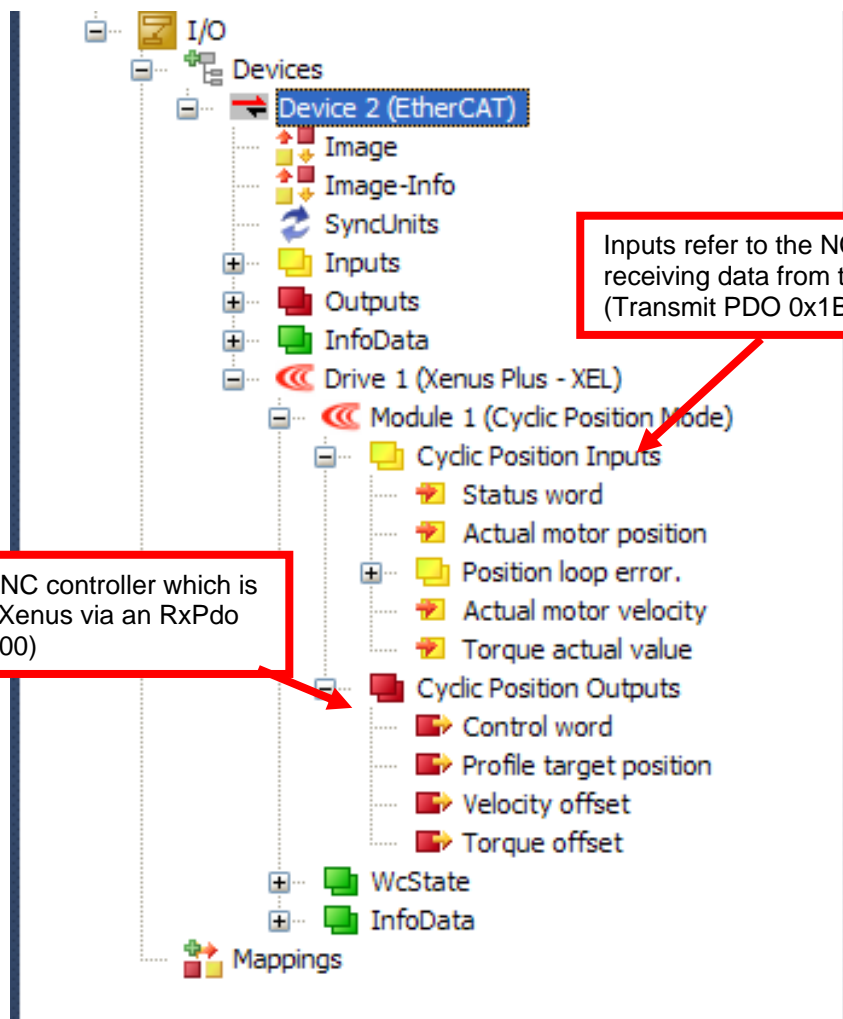

Outputs refer to the NC controller which is sending data to the Xenus via an RxPdo (Receive PDO 0x1700)

Inputs refer to the NC controller which is receiving data from the Xenus via TxPDO (Transmit PDO 0x1B00)

Opening the NC controller shows its construction. Each Axis is an NC that is linked to a drive (or one axis of a 2-axis drive) on the network. The Enc (encoder) will receive position data from the drive. The drive Inputs will receive status information. And, the drive Output will be sending position/velocity/torque data to the drive.

These connections are for the CSP (Cyclic Sync Position) operating mode which is the default mode in the ESI file



Below is the Xenus RxPdo 0x1700 which receives data from the NC Outputs nCtrl1 & nCtrl2 which are each 1 byte requiring two of these to compose the 16-bit (2 byte) Control Word:

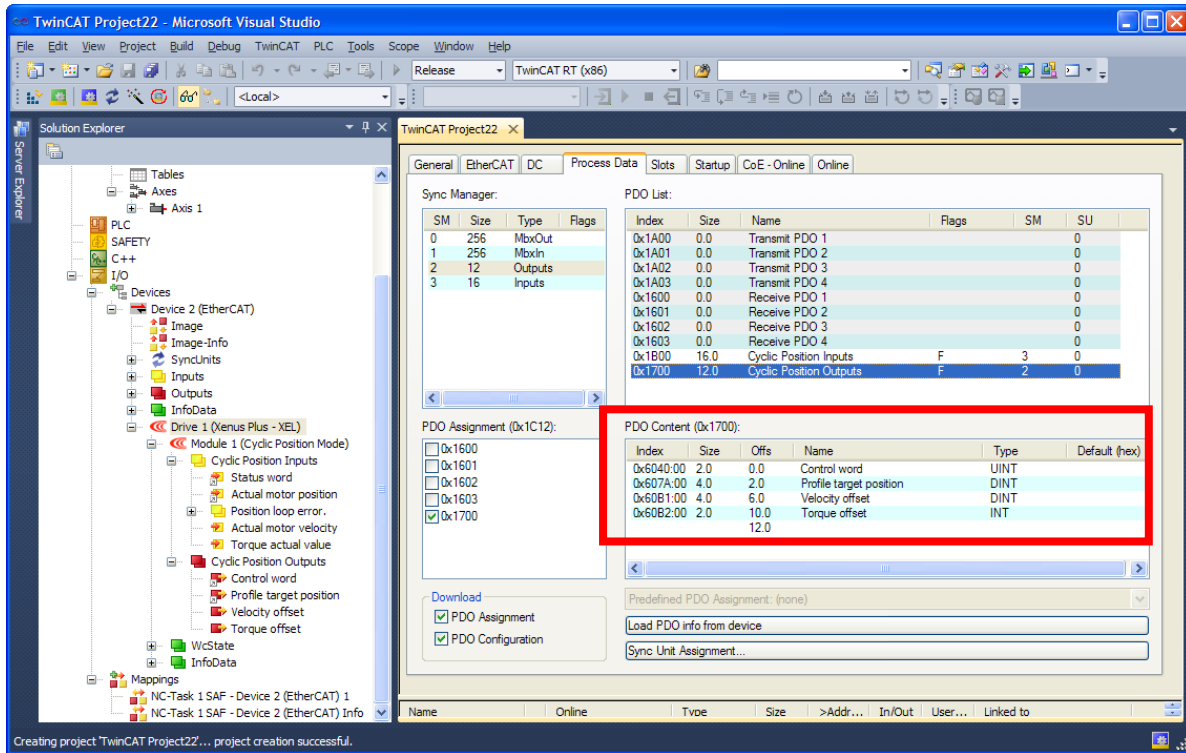

Below is the Xenus TxPdo 0x1B00 which transmits data to the NC Encoder and Drive Inputs:

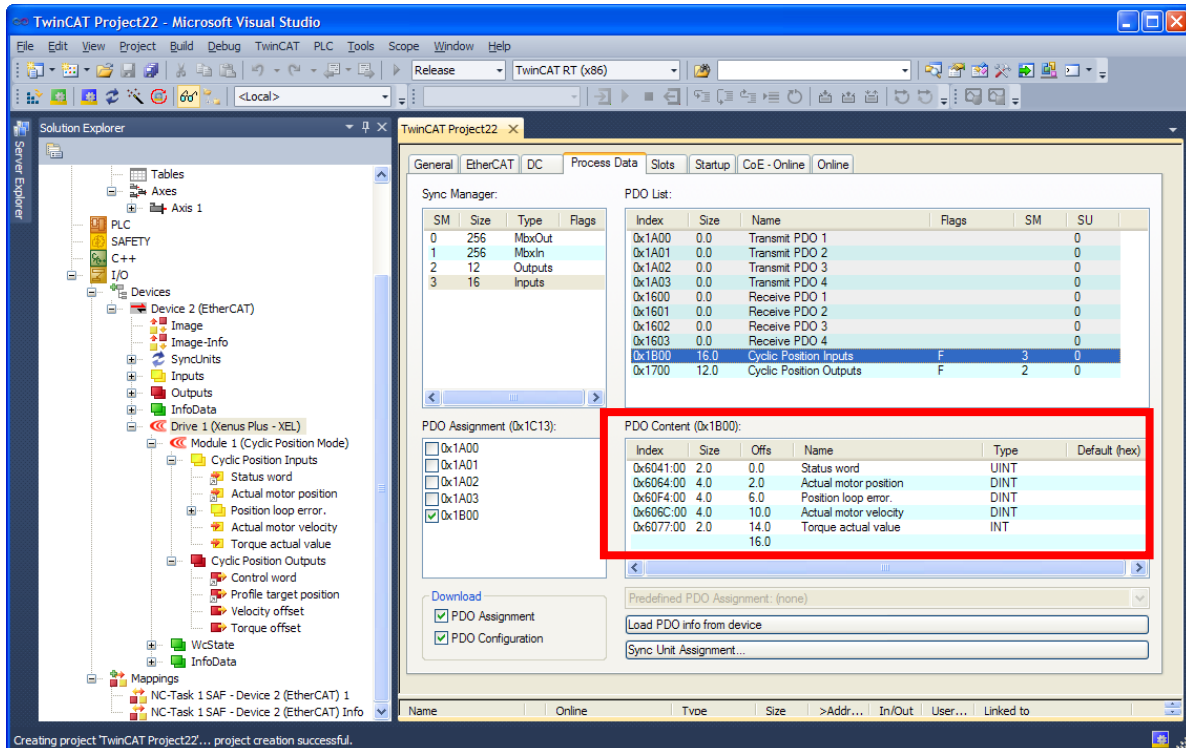

Setting Up the NC Controller

After the connections have been made automatically by TwinCAT 3, it is necessary to configure the following settings in the NC controller for the drive and motor combination:

- Scaling factor (Units of position measurement)
- Maximum speed
- Jogging speed (Fast, Slow)
- Acceleration limits (accel, decel)
- Monitoring (of various conditions)

Encoder Scaling Factor

Understanding “mm/INC”

Units of position in TwinCAT 3 are user-settable using the mm/Inc factor.

- “mm” = User unit of position (rotary or linear)
- “INC” = Position change per increment of feedback (encoder count)

Opening the Axis 1 Enc, Parameter tab will show the parameters for the feedback units.

For this example, this is the screen from CME2 that shows the encoder data:

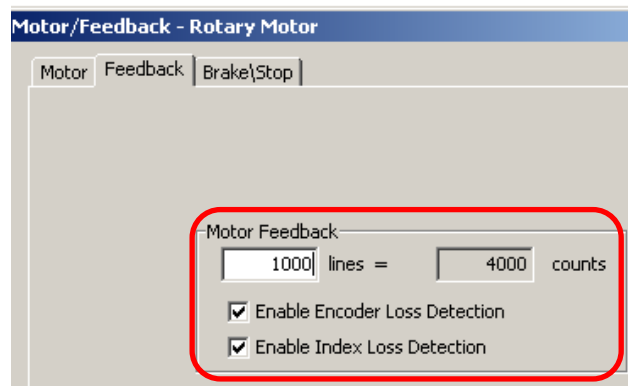

Taking the 4000 counts/rev and inverting it gives the INC factor of 1/4000, or 0.00025 revs/count. The screen below shows the default setting of the Scaling factor as 0.0001:

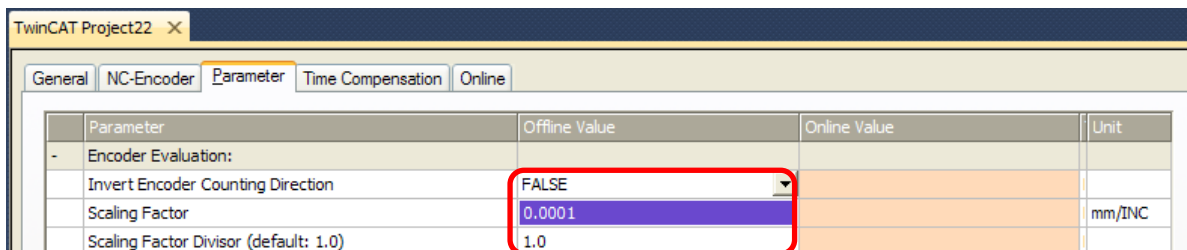

Double-clicking this and changing it to 0.00025 should produce this result:

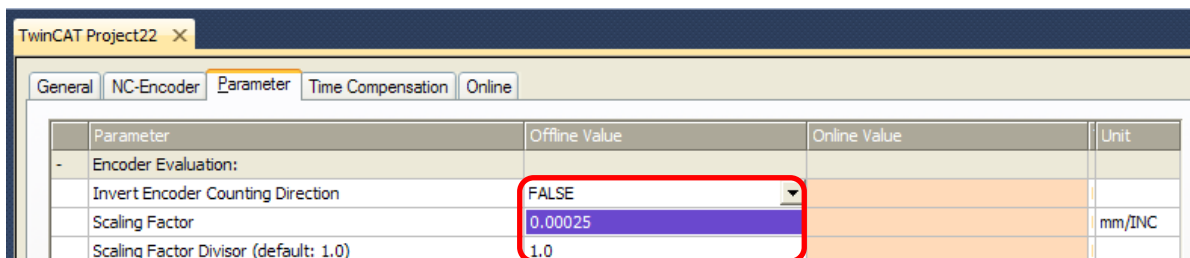

NC Axis Settings

In the TwinCAT 3 Solution Explorer window (folder tree) click on Axis 1, and then on the Parameter tab. The settings highlighted below are the ones to adjust for the motor/drive combination used. This assumes that the motor is free to move, and that there are no limit or home switches.

From the mm/INC settings, the unit of position is “rev”, or revolution of a rotary motor. In this screen the units to be set should be read like this:

- mm = rev (revolutions) Distance
- mm/s = rev/sec Velocity
- mm/s² = rev/sec² Acceleration
- mm/s³ = rev/sec³ Jerk

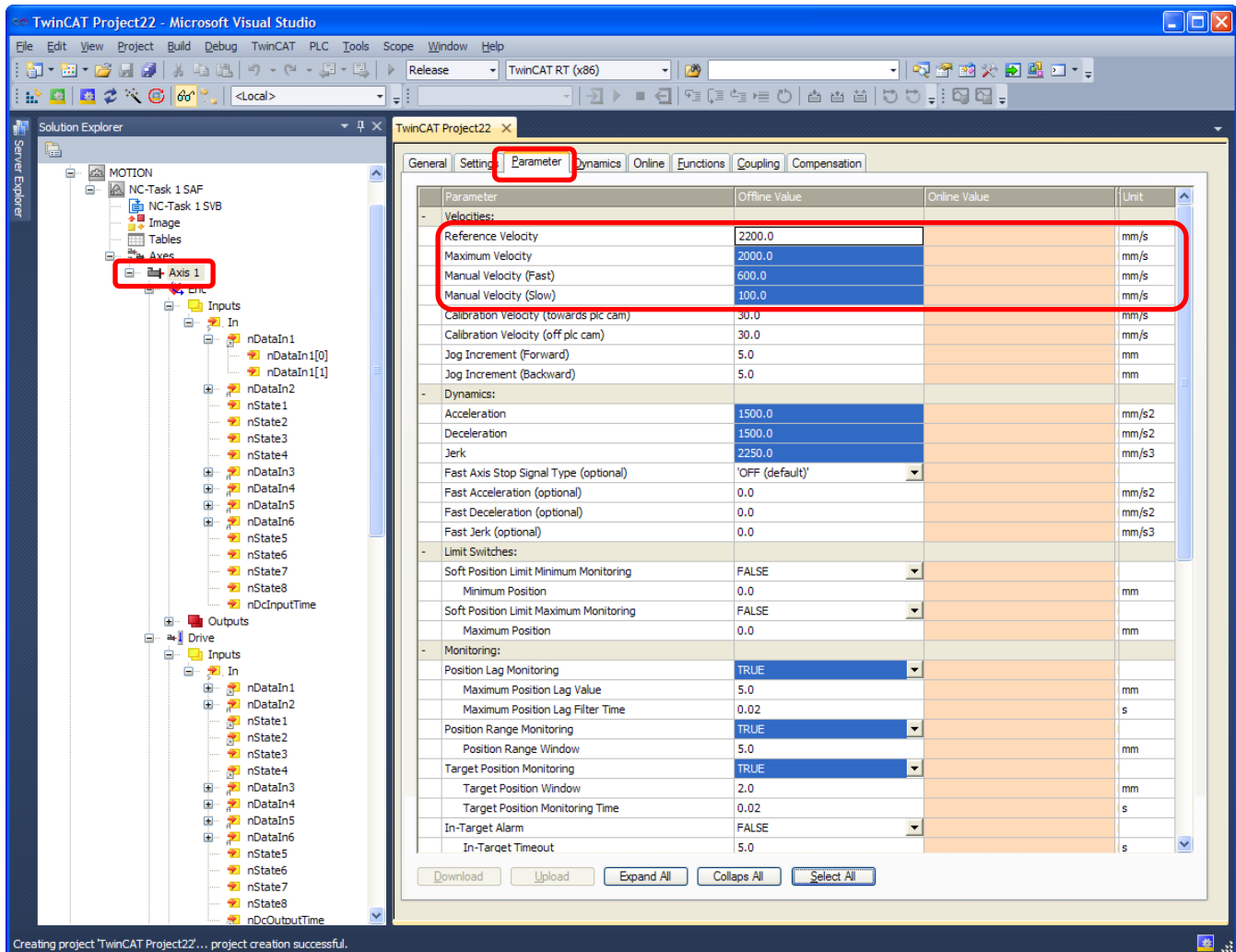

NC Axis Settings (cont')

Maximum Velocity: Set to ~90% of the value shown in the CME2 V-Loop window:

In this case, that would be $7000 \times 0.9 = 6300$ RPM (rev/min)

Convert that to rev/sec: $6300 / 60 = 105$ and double-click to edit Maximum Velocity and make it 105.

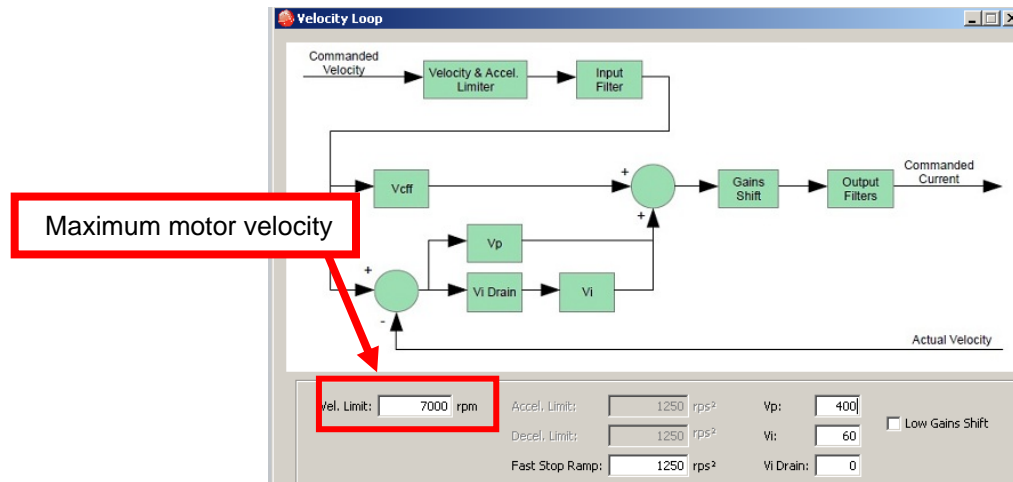

Manual Velocity (Fast) = Speed for the fast jog setting in the NC Online screen.
300 RPM is a common setting, or 5 rev/sec.

Manual Velocity (Slow) = Speed for slow jog setting in the NC Online screen
A good factor here is 1/5 of the Fast Jog speed, 60 RPM, or 1 rev/sec.

Acceleration Assume that the time to 6300 RPM is 1 second,
or $(105 \text{ rev/sec}) / (1 \text{ sec}) = 105 \text{ rev/sec}^2$

Deceleration For this example, use the same value as acceleration

Jerk Multiply Acceleration X4 to get to the same velocity in the
same time = $4 \times 105 = 420 \text{ rev/sec}^3$

Position Lag Monitoring Also known as following-error, turning this off during commissioning will eliminate halting during the system tuning/commissioning process. Doing this does assume that the motor/load combination can tolerate some mis-positioning without damage.

Position Range Monitoring & Target Position Monitoring Together, these indicate a "Move-done" condition in which the trajectory generator is no longer busy, and the motor is within the position range of the target position.

System Real-Time Settings

The RT (Real-Time) CPU time is the fundamental time unit at which the RT kernel operates. And, within the RT kernel, multiple tasks can operate. The default for this is 1 ms, with each ms seen as a “tick” of the RT clock by other tasks.

The NC Task 1 SAF produces the cyclic-synchronous data updates to slaves on the network. The default setting is 2 cycle ticks of the RT clock, resulting in a Cycle Time of 2 ms for the SAF task.

The NC Task 1 SVB is the calculation engine in the NC controller that does the math for the motions to be executed. The results of these calculations are passed to the SAF task to update the drives. The default timing for this task is 5X the cycle ticks of the SAF task, resulting in 10 ms.

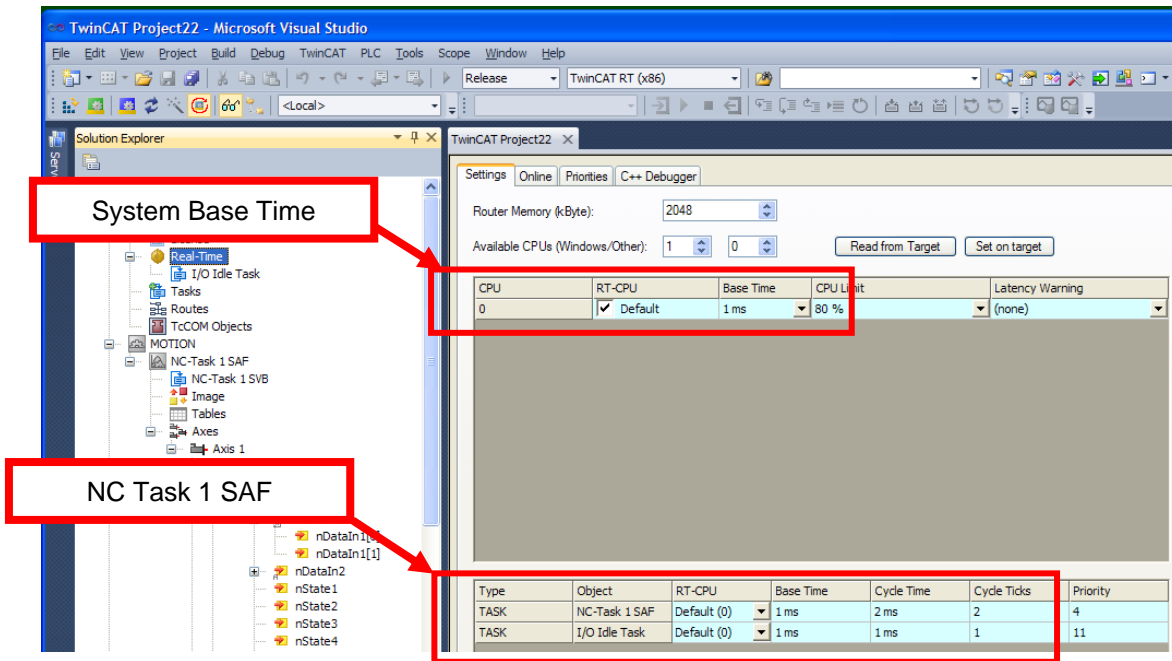

It is possible to run TwinCAT 3 at these timings, but operation at these defaults will produce some audible noise in the position loop operation. Smoother operation is possible when cyclic position (or velocity) updates occur at the 4 kHz rate of the Xenus, Accelnet, and Stepnet Plus drives. To set up these timings, begin with the following setting of the Base Time RT-CPU:

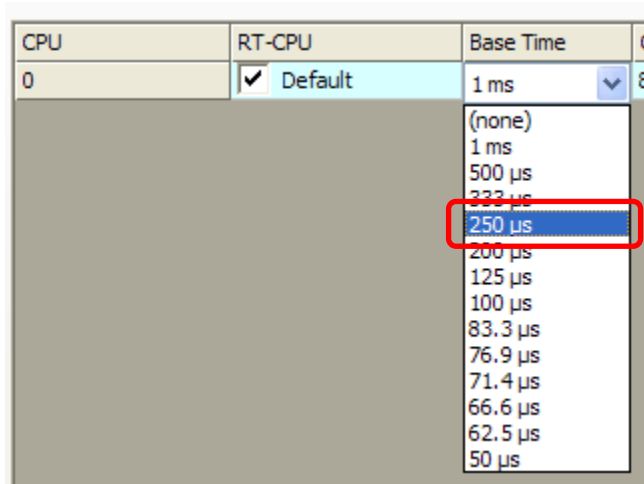

Next, scroll down to the NC Task 1 SAF item under the Motion part of the TwinCAT 3 folder tree. Click on this to open this screen. Change the Cycle ticks number to 1. The result should look like this:

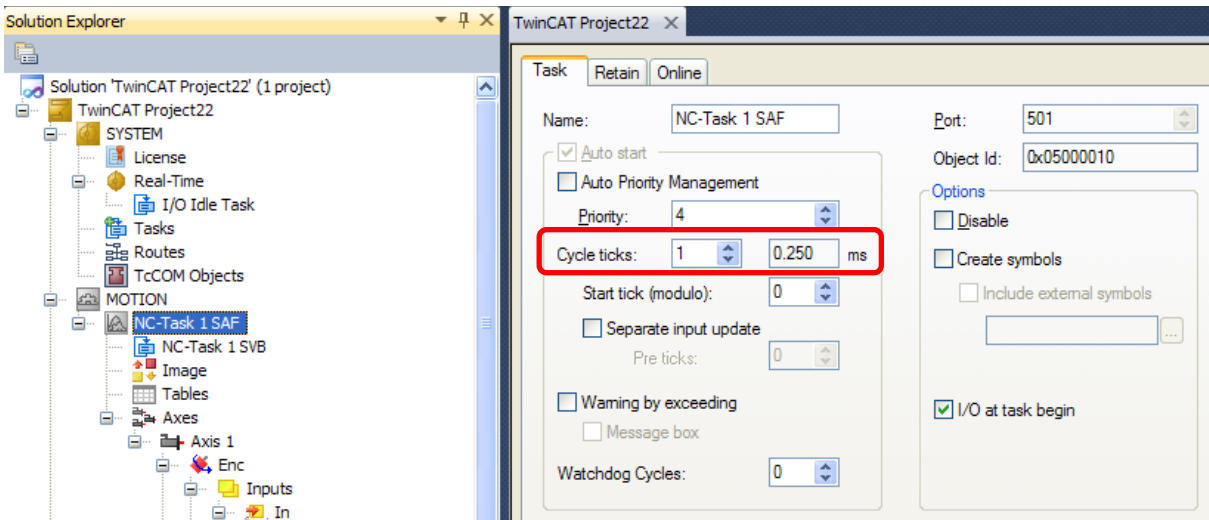

Now, click on NC-Task 1 SVB and set that to 5 Cycle ticks. This should be the result.

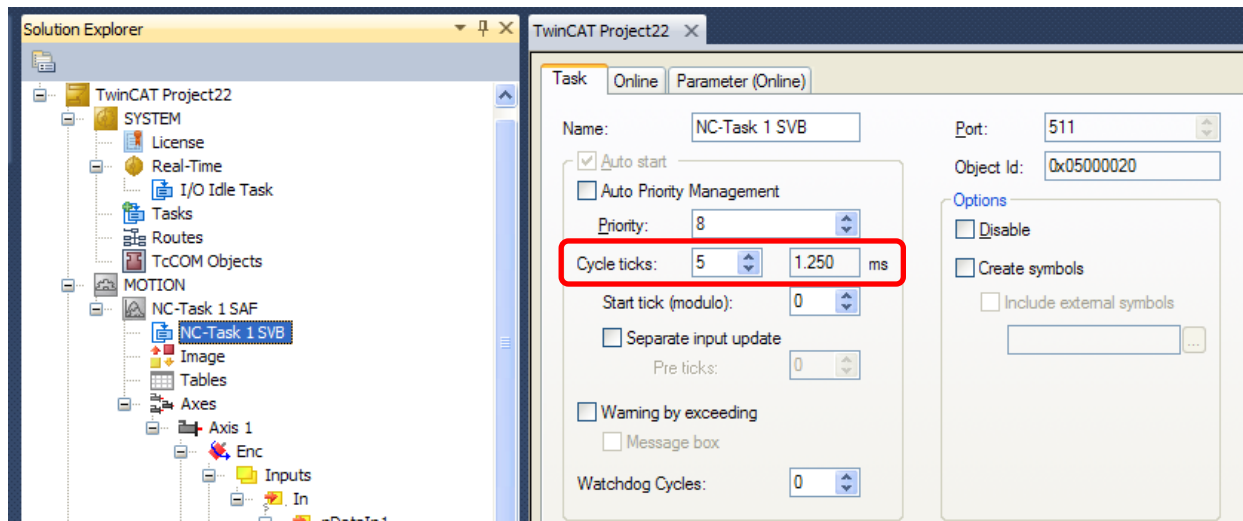

To summarize these settings:

Parameter	Default	4kHz
Base Time	1 ms	250 us
NC-Task 1 SAF	1 ms	0.25 ms
NC-Task 1 SVB	1 ms	1.250 ms

Setting these is easy, so is 4kHz the best choice? The answer depends greatly on the characteristics of the computer that is running TwinCAT 3.

For now, leave the settings at the 1 ms default values. When the system is started it will be possible to display the jitter in the task timings using TwinCAT 3. If the jitter is low, then the timings can be set up to the 4kHz numbers.

RT Kernel Time-Base Stability

“Stability” describes the uniformity of the time between updates of the slaves on the network. Ideally it will show no variation. In practice, it will frequently vary widely and inconsistently.

With the settings made in the NC for encoder resolution, velocities, and accelerations, the next step is to *Activate* the configuration. This compiles all of the settings in the Visual Studio interface, downloads them to the RT kernel, and starts the kernel in Run model

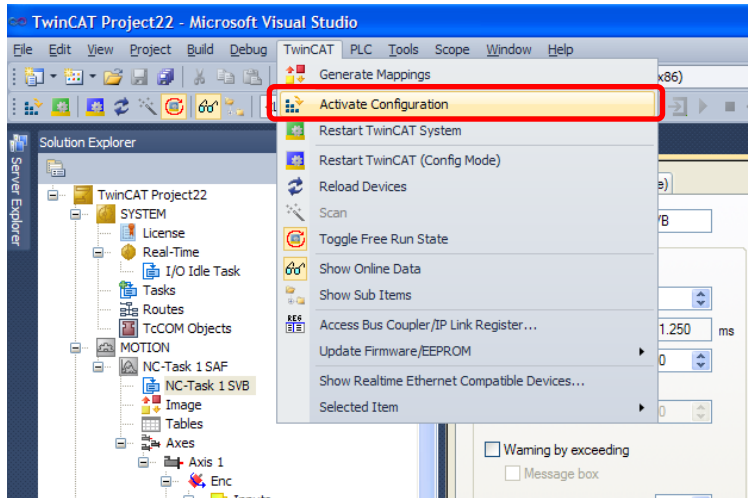

This produces this screen (click OK), followed by the license-missing screen. Click [Yes] to generate a trial license:

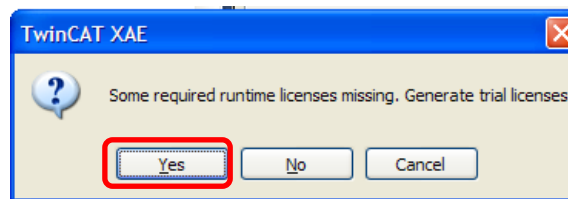
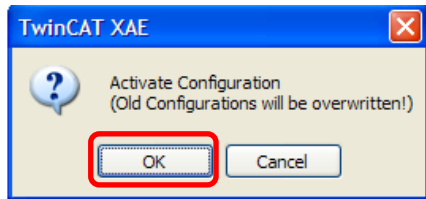

Simply enter the characters shown in the window and this will activate a trial license. Click [OK] to Restart TwinCAT System in Run Mode:

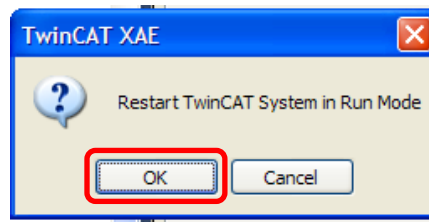
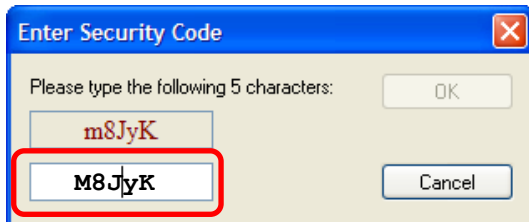

RT Kernel Check #1

Navigate to the System > Real Time icon in the folder tree and click on the Online tab to the right. This screen shows the percent-usage of the computer's CPU and the System Latency. The System Latency is the time at which the system time-tick arrives too late for the RT kernel.

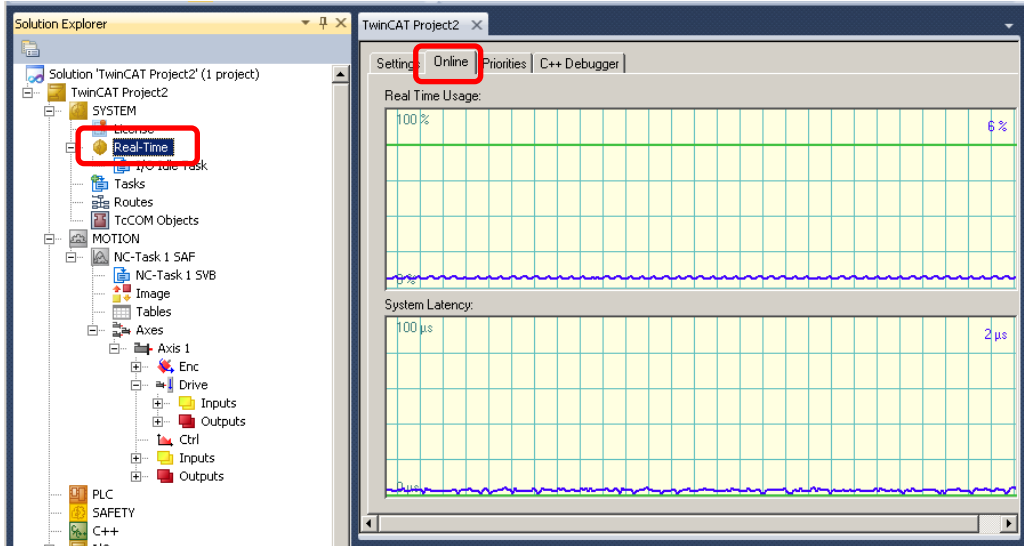

RT Kernel Check #2:

Scroll down to the folder the I/O>Devices>Device4 (EtherCAT), double-click that to open, then select the EtherCAT tab>Advanced Settings button. Open the Distributed Clocks>Diagnosis item. This shows the number of network packets under different deviations of the timing. None of them are greater than 20 us.

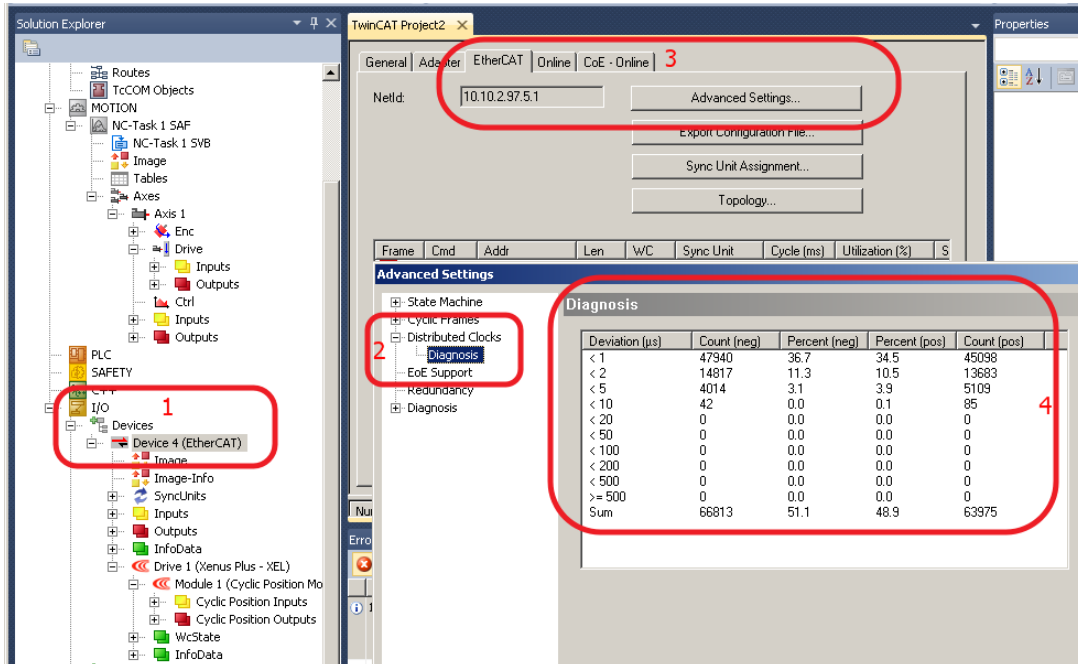

These data were taken from a Beckhoff C6920 industrial PC and show a high degree of stability of the system timing. The same TwinCAT 3 installation on desktop or laptop computers will typically show much larger deviations in the system timing.

Activating the Configuration

With the NC, encoder, and parameters all set, the configuration is ready for *activation*. This is the operation that takes the configuration in the engineering interface (Visual Studio) and downloads it to the RT kernel. While shortcut keys are shown in other Menu bar options, they are missing from the TwinCAT objects. Because these are used frequently and are valuable time-savers, they are show below:

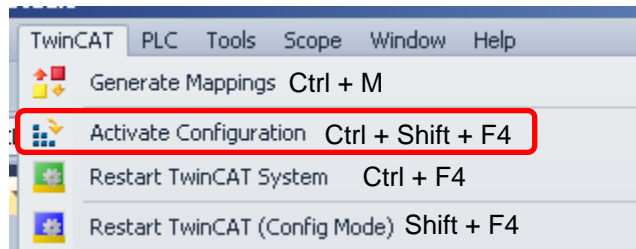

Activation will automatically generate mappings and switch TwinCAT to Run mode: The RT kernel is running, datagrams are generated connecting the nodes with real-time PDO updates.

Config mode stops the RT kernel. Free Run will query the network devices and allow alteration of their data, but the slaves will not be enabled for motion control.

NC: Online

After activation, click on the Axis under the MOTION..Axis 1 item and open the Online tab. This mimics the control panel of an NC controller with jogging and other user buttons. Click **[Set]** in the Enabling frame, and select **All** to enable the drive.

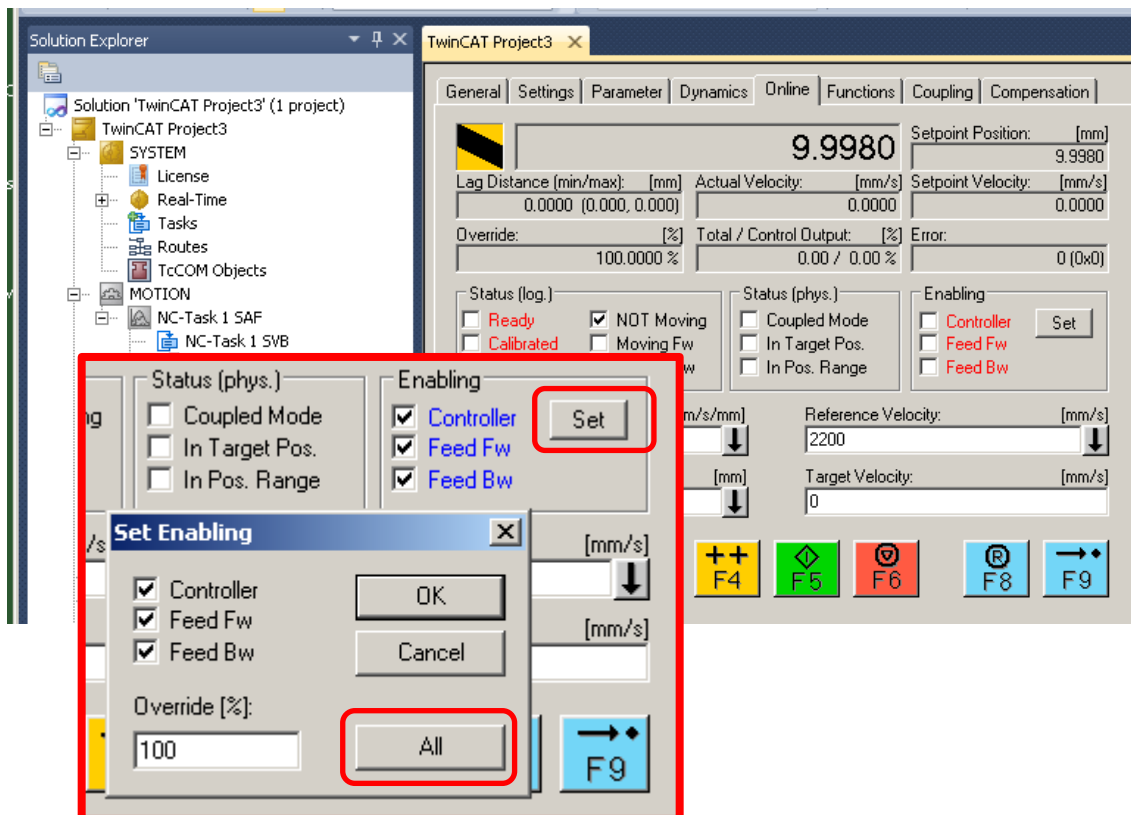

Enabling the drive from an EtherCAT master can be seen via the Control Panel of CME2. The graphics below show the NC controller's Enabling frame in red, and the CME2 Control Panel indicators showing the effects of network enabling (software enabling) of the drive.

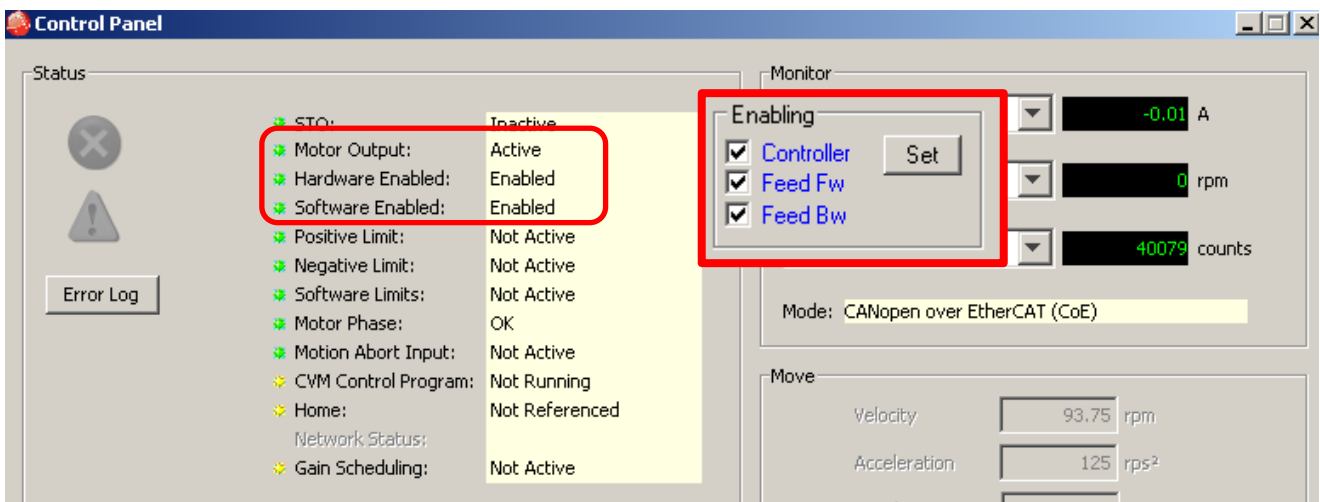
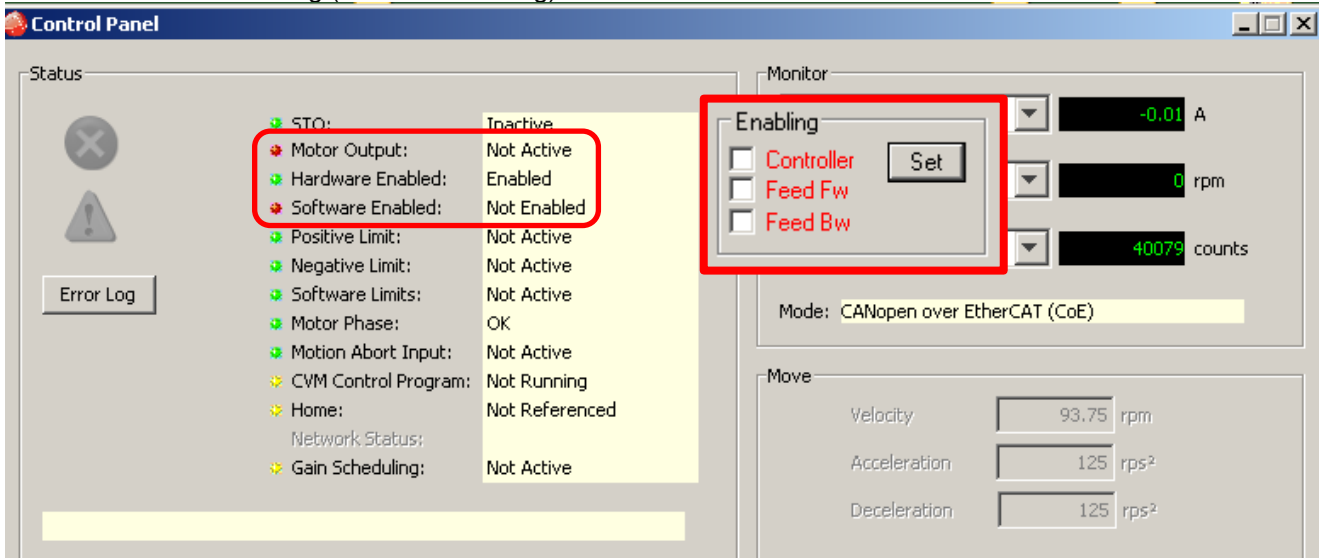

NC: Manual Control

Jogging

The F1~F4 keys are used to jog the drive pos/neg at the Manual Velocity (Fast) and Manual Velocity (Slow) rates that were set up in the NC Parameters tab > Velocities section.

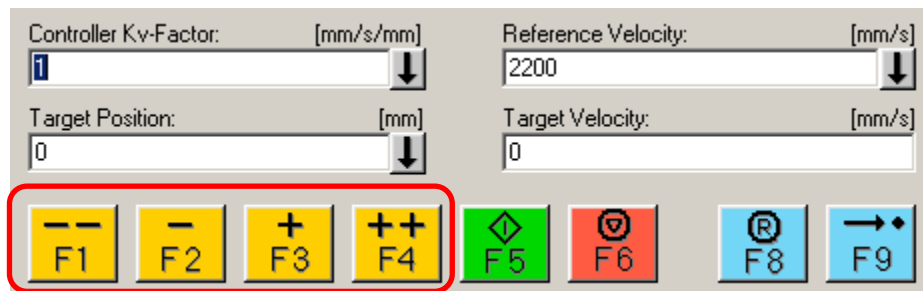

Single Move: Target Position

This value sets the destination in absolute coordinates for a single move. It is in the position units used (“mm”). In this example, the unit is “rev” or revolutions of the motor. Entering 25 would mean 25 revolutions.

Single Move: Target Velocity

Units are the rate of change of the position units. In this example, that would be rev/sec. Entering 40 would be 40 rev/sec, or 2400 RPM.

Single Move: Acceleration/Deceleration

Acceleration/deceleration values remain as they were configured in the NC Parameters tab. They can also be displayed in the Dynamics tab. The default presentation is shown below. The dynamics can also be changed here with the various Direct and Indirect controls.

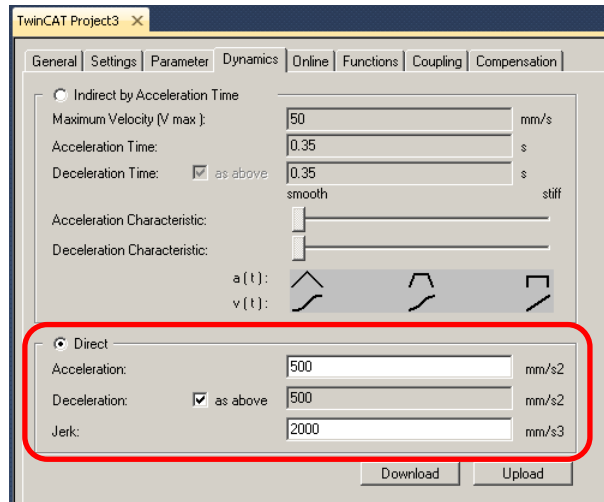

NC: Setting Absolute Position to Zero

In TwinCAT 3, Homing is called Referencing and involves a number of settings which will not be covered in this tutorial. However, it is possible to jog a motor to a position that can be set to “0” after which moves can be performed in absolute position coordinates.

Step 1: Jog the motor to the position that will become “home”.

Step 2: Open the Functions tab of the NC > Set Actual Position frame. Check for “0” in the number box and press the [Set] button. The position on the display box above will go to 0 (absolute).

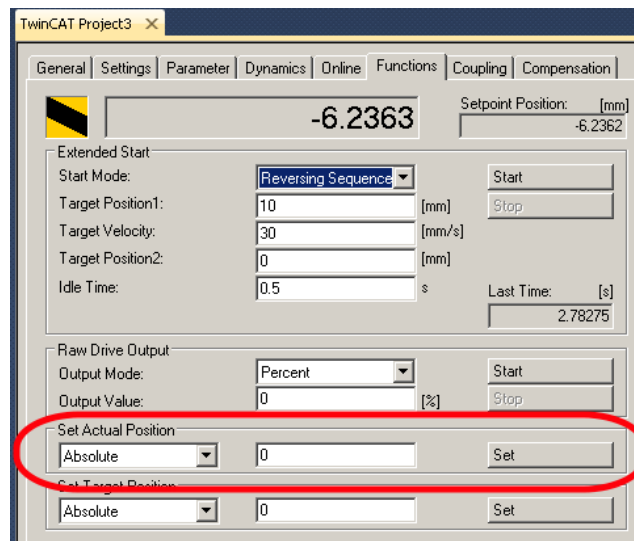

NC: Out/Back Repeating Positions

For tuning an axis over EtherCAT, the NC has a feature that is similar to the Function Generator in CME2. This is particularly useful because in CME2, the drive is controlled by an internal trajectory generator that is performing profile-position moves in which the accel/decel, velocity, and target position are fixed values. In an EtherCAT master in CSP (Cyclic Sync Position) mode, the trajectory generation is in the master. The servo drive only sees increments of position with every PDO and has no knowledge of the final target position or velocities. And the rate at which the updates arrive depends on the time-base of the master. So, setting up out/back moves over EtherCAT enable tuning of the system under actual operating conditions.

Step 1: Open the NC Functions tab > Extended Start frame, and pull-down the Start Mode menu to Reversing Sequence. Note the 0.0000 position (after zeroing) which will be the starting position for the reversing moves.

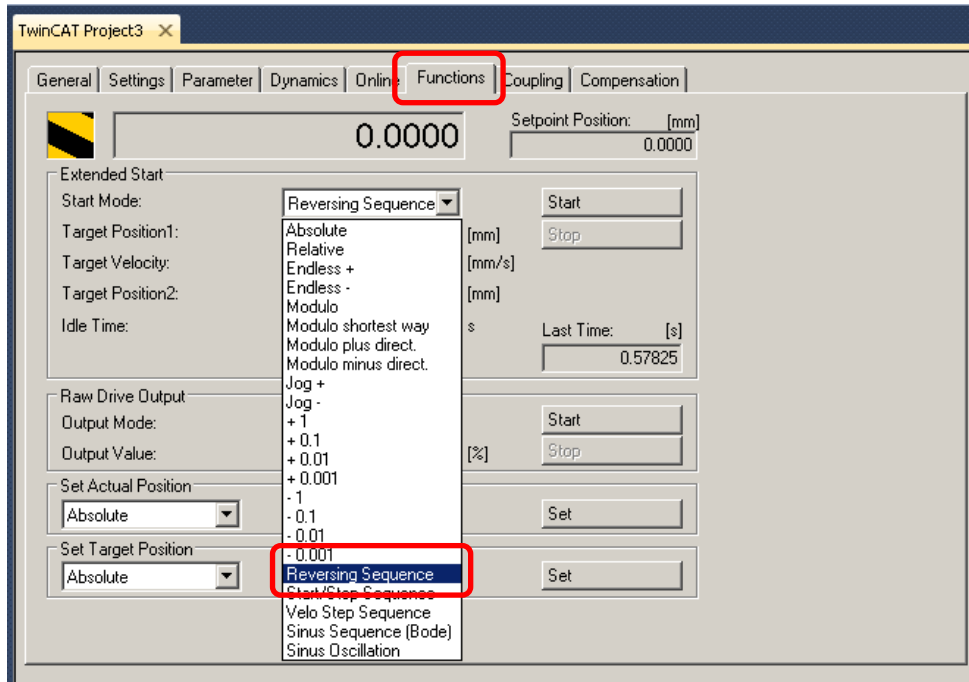

Enter values for Target Position1 (Out position), Velocity, Target Position2 (0 for Back position), and Idle Time (dwell). Press [Start] to go, and when running press [Stop] to halt. If Stop is pressed for a move in progress, pressing Start will resume motion without losing the absolute position reference of the moves.

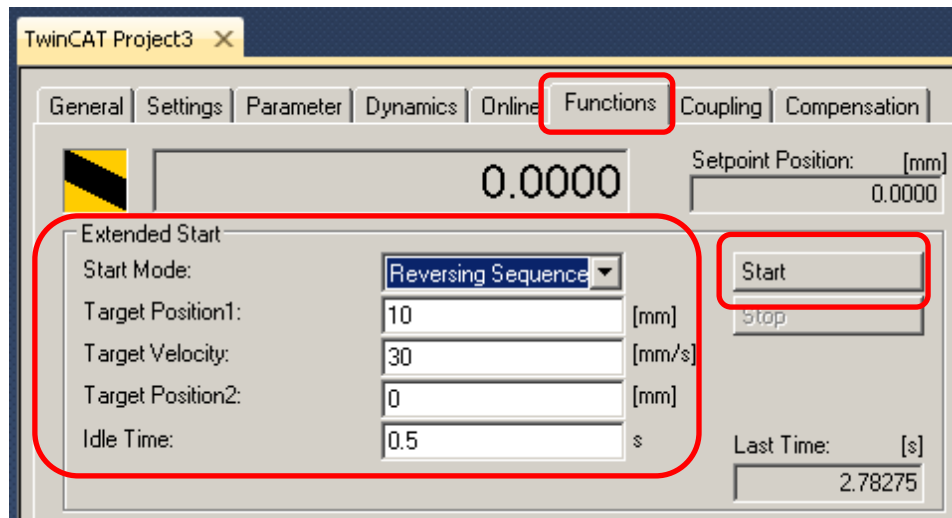

When final tuning has been done, the drive is ready to be operated by the EtherCAT master.

Switching Runtime with TwinCAT 2

If your computer already has TwinCAT 2 installed, then adding TwinCAT3 means that there are now two real-time kernels in the system. Only one of them can operate at the same time, so how to know which one is running?

Fortunately Beckhoff planned for this and there is an application that will get things sorted nicely.

Find it here, and double-click on *TcSwitchRuntime.exe*

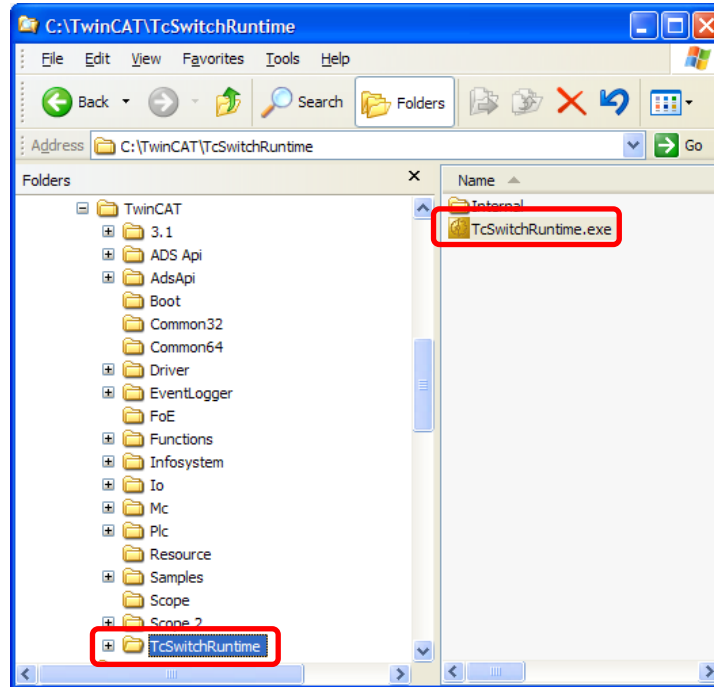

Here's how it looks with both TwinCAT 2 and TwinCAT3 active:

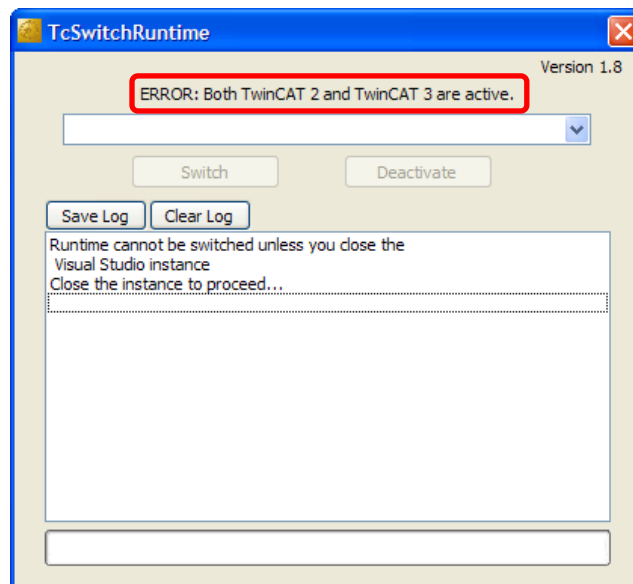

In order to proceed, the instance to be closed will be TwinCAT3, so close this screen now and

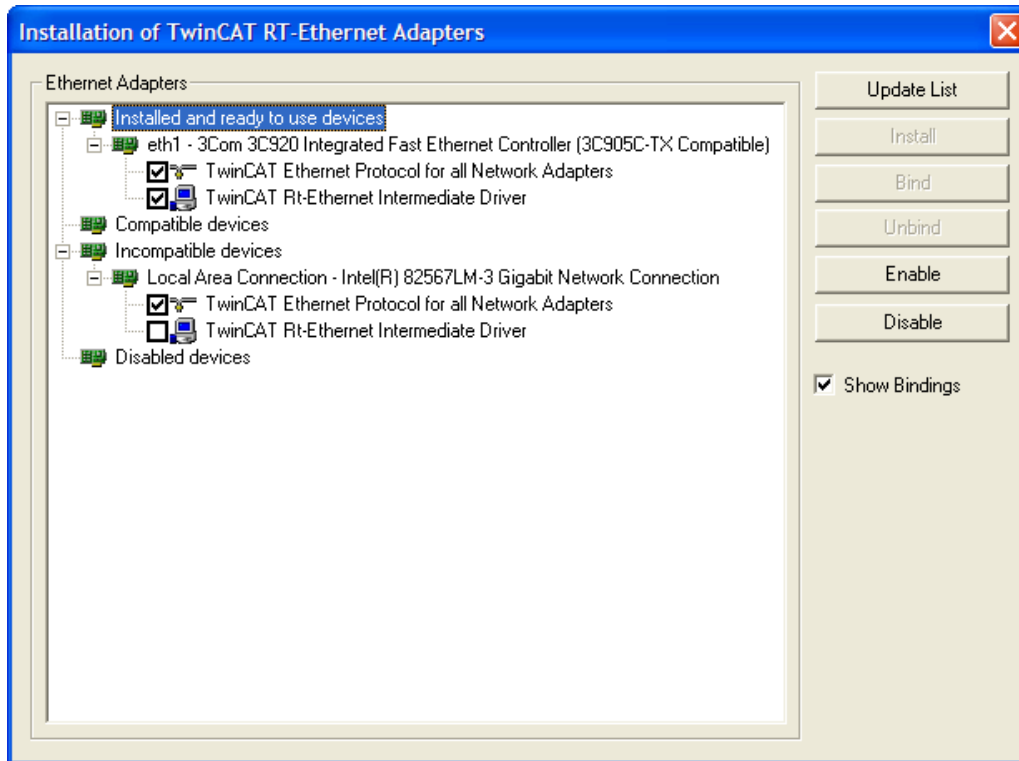
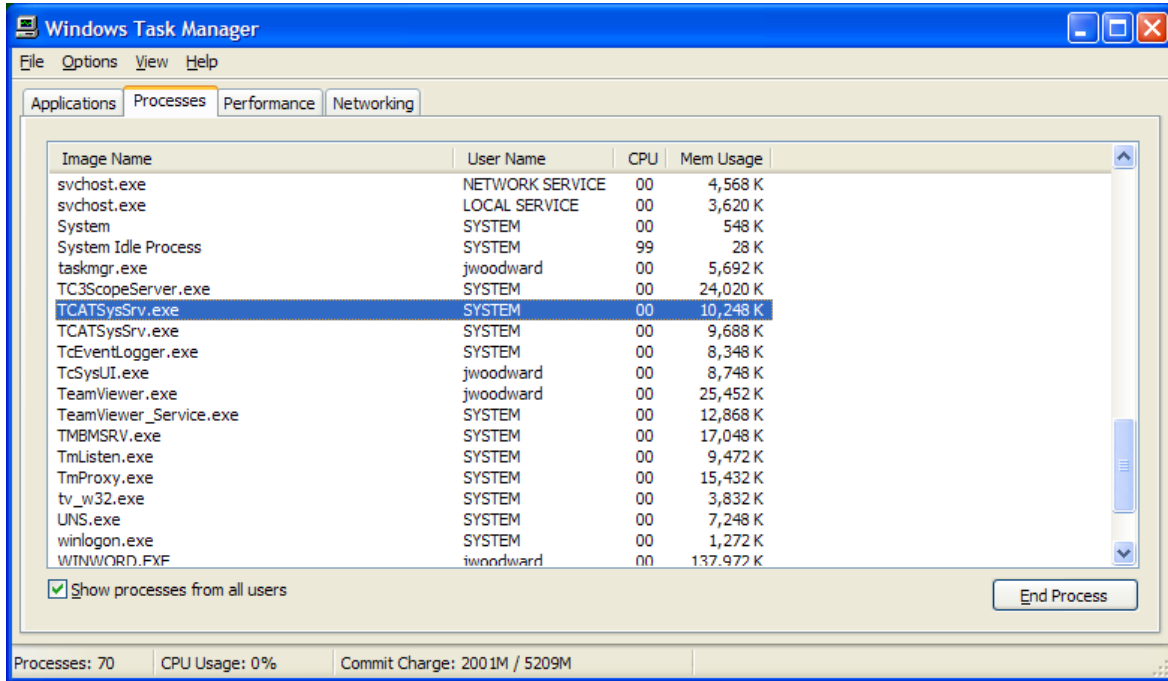

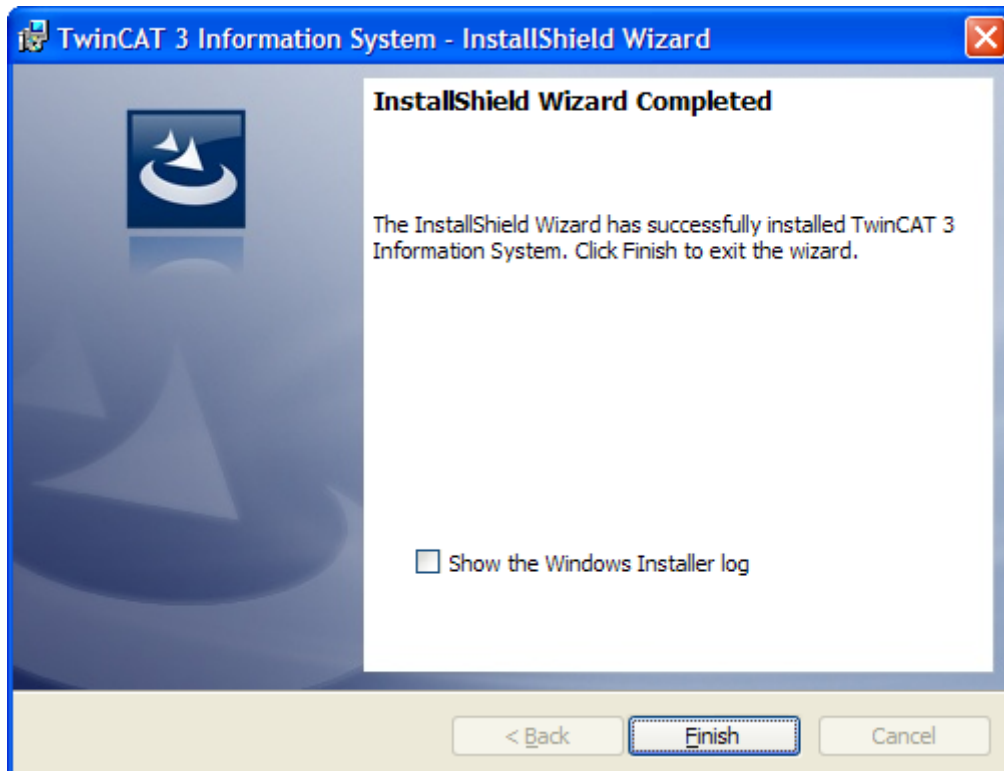
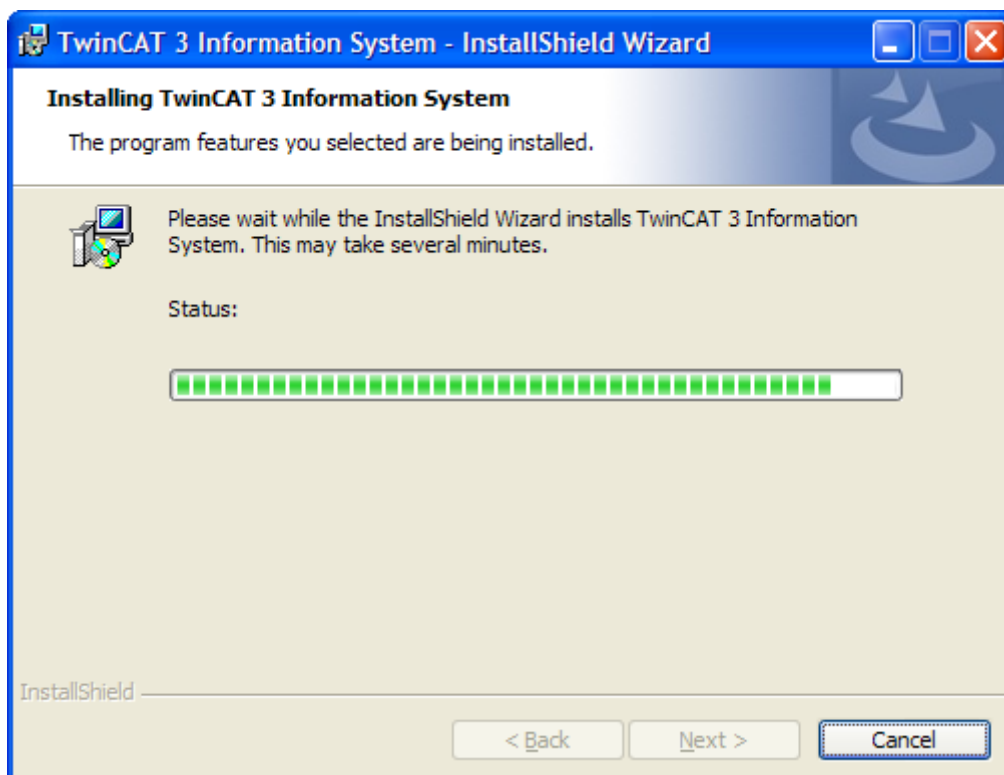

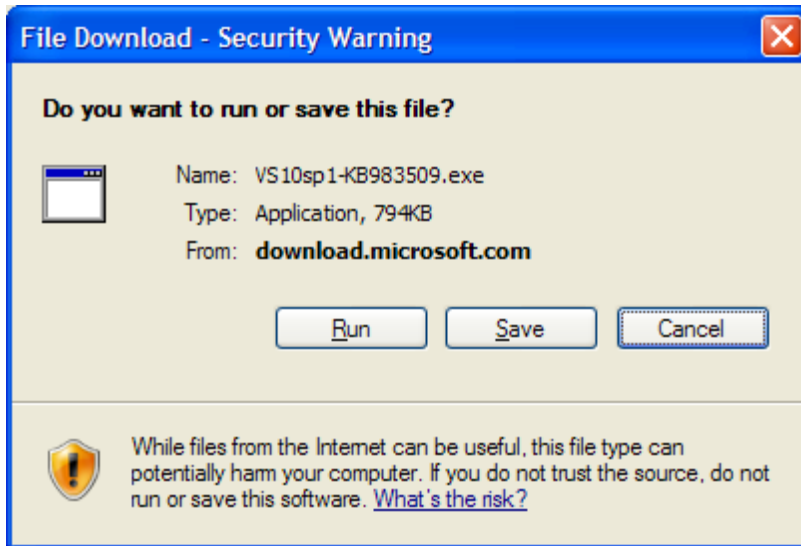
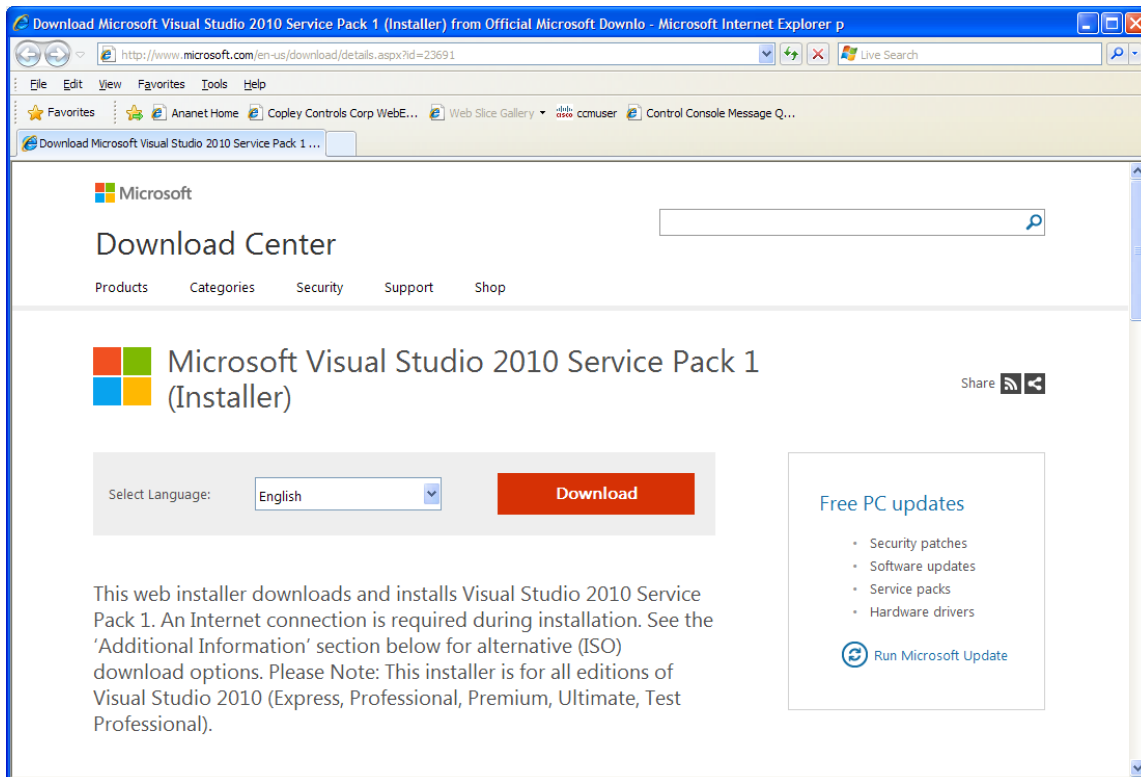

6.2 Beckhoff TwinCAT 2

Introduction

This document provides information on commissioning Copley Controls EtherCAT servo drives using the TwinCAT 2 EtherCAT master software. When these steps are followed, it should be possible to move a servo motor via a Copley Controls servo drive from the NC controller in TwinCAT 2. For more advanced motion control it is necessary to consult the Beckhoff InfoSystem software for details.

Step 1: Configure the Drive for EtherCAT Operation

- Install CME2
- Run Basic Setup to configure the drive for Position mode, and Command Source as CANopen over EtherCAT (CoE).

Step 2: Download the ESI (XML) File from the Copley web-site

The file is found here: <http://www.copleycontrols.com/Motion/zip/ecatxml.zip>
Download it to your desktop, or other folder for now.

Step 3: Assign an Ethernet Port on Your Computer to EtherCAT

EtherCAT requires a dedicated NIC (Network Interface Card). It does not share a port with other Ethernet traffic and should not be run from an Ethernet switch.

Step 4: Download the TwinCAT 2 Software and Install It

The TwinCAT 2 software will run for 30 days in Demo mode and can be re-installed after that time. It is on the Beckhoff web-site here: <http://www.beckhoff.com/>
Navigate to Download -> Software -> TwinCAT 2 30 days version -> Download: TwinCAT 2
Fill out the form and download the file. After that, run Setup to install TwinCAT 2.
DO NOT LAUNCH TWINCAT 2 BEFORE INSTALLING THE ESI FILE !

Here is the sequence of screens you will see during the TwinCAT 2 installation.

Language selection

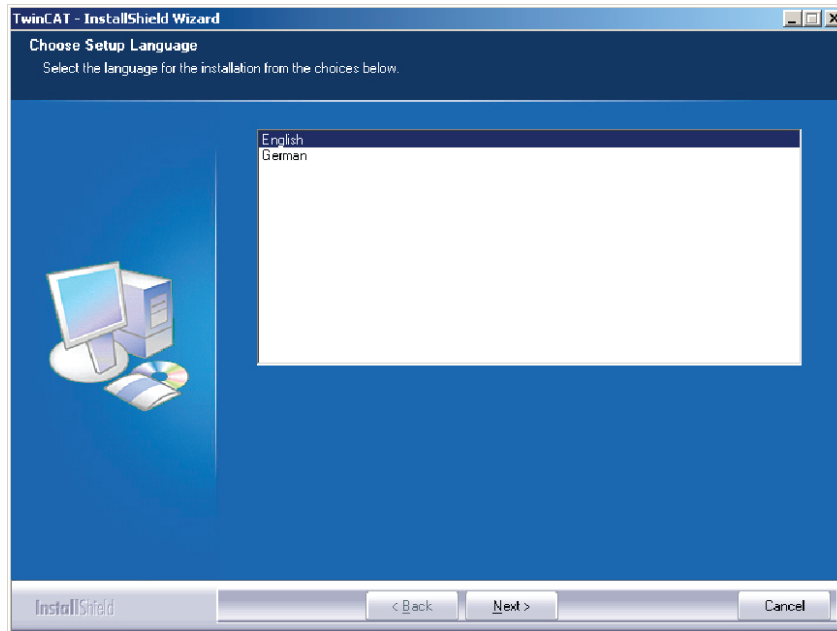

Click-through EULA

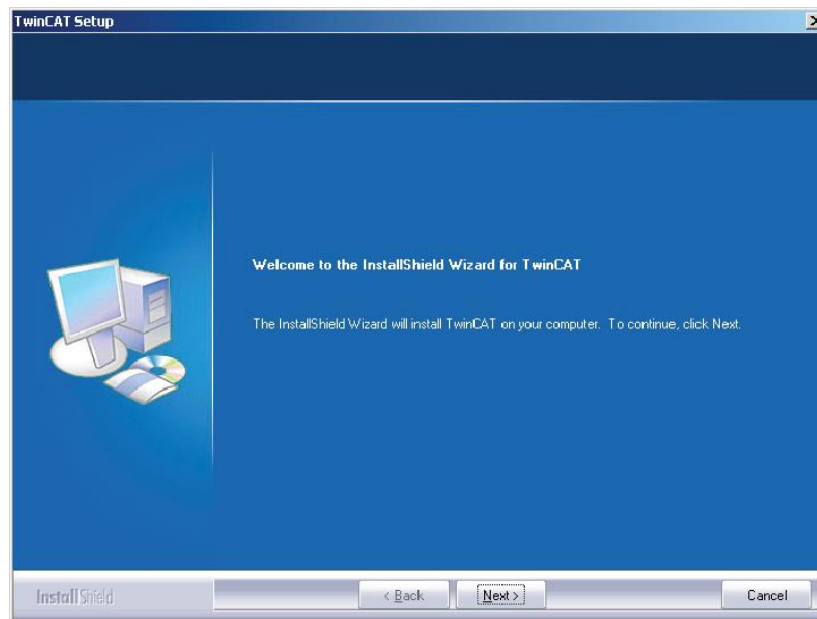

After Welcome, Accept

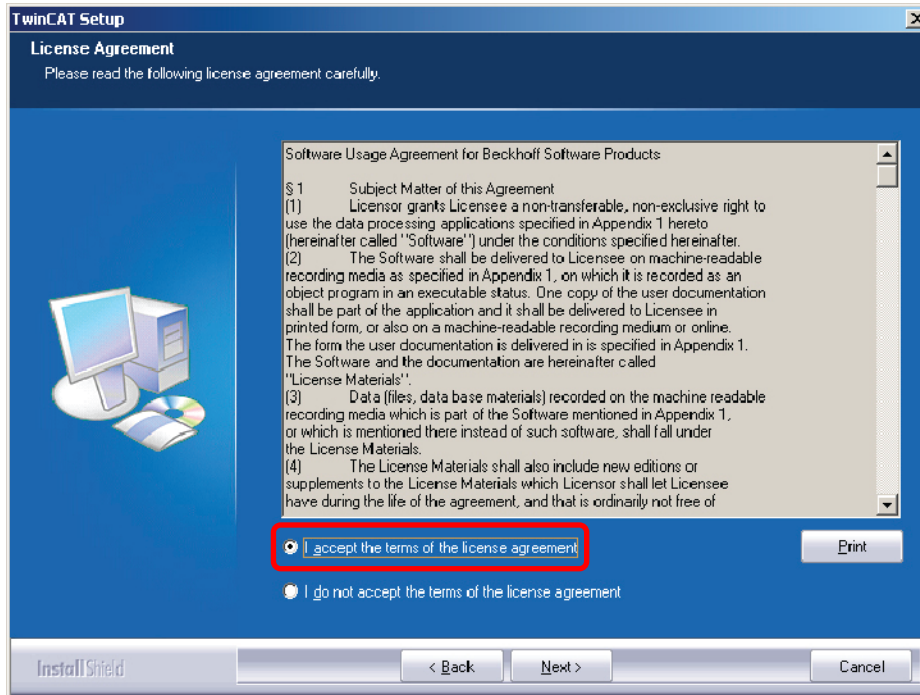

Name & Company Entry

Leave serial number blank, but a company name is necessary to proceed to the next step.

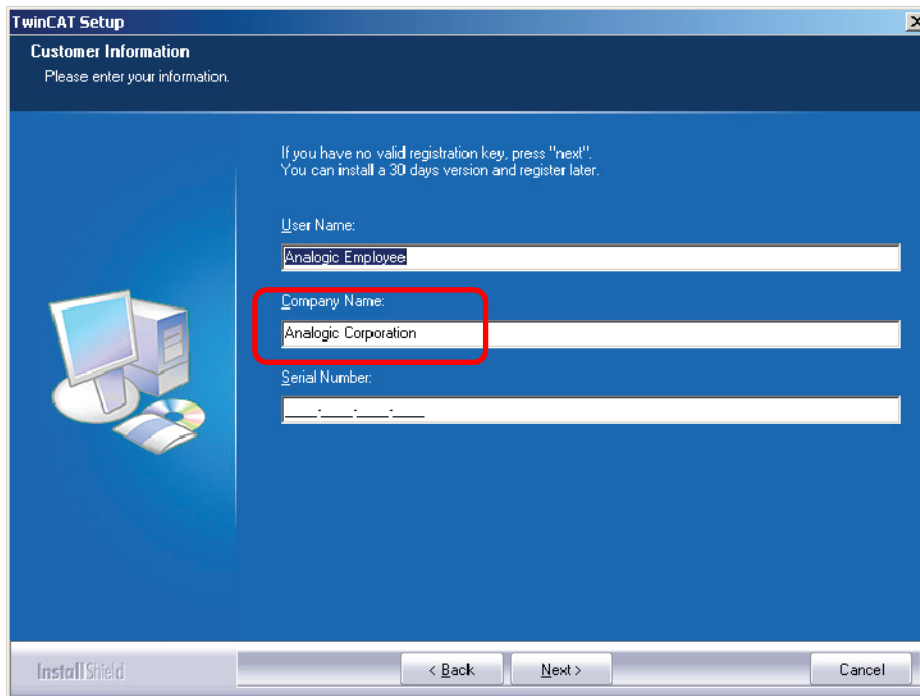

Installation Level Selection

Check the NC PTP item now and all of the items above it will be installed. This stands for Numerical Control (NC) Point-to-Point (PTP).

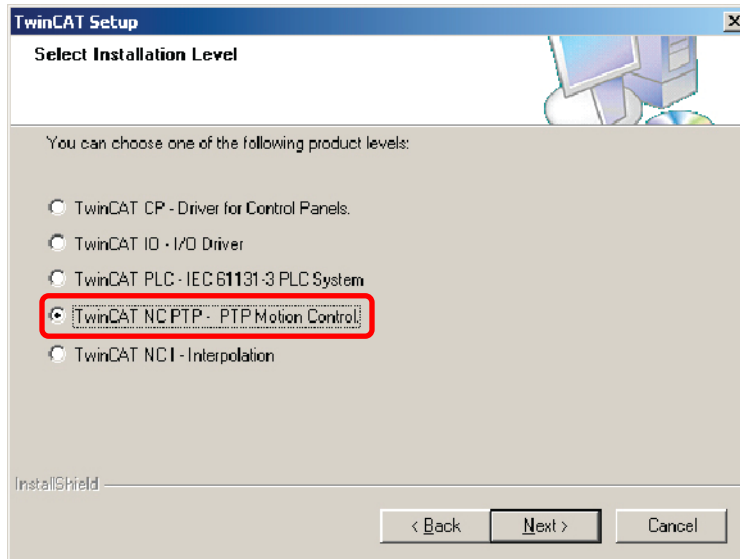

Version Selection

Check the 30 days demo, assuming you are a first-time user and not purchasing TwinCAT 2 at this time.

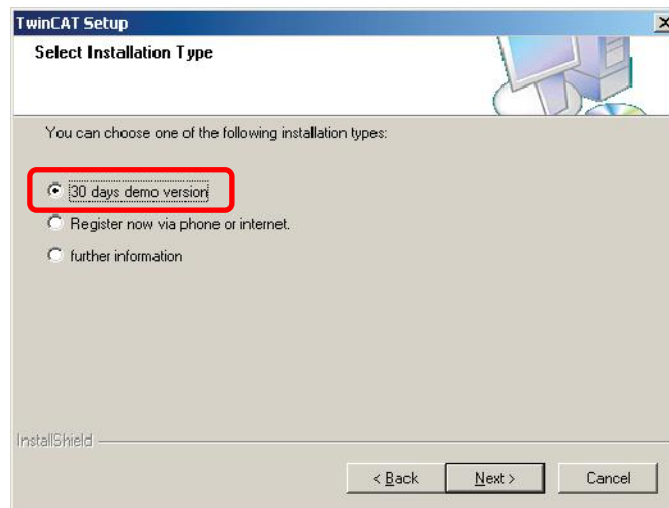

Feature Selection

The default selections are shown below. None are required for running a servo drive with the NC controller so you can leave these as shown unless conservation of hard-drive storage is a goal.

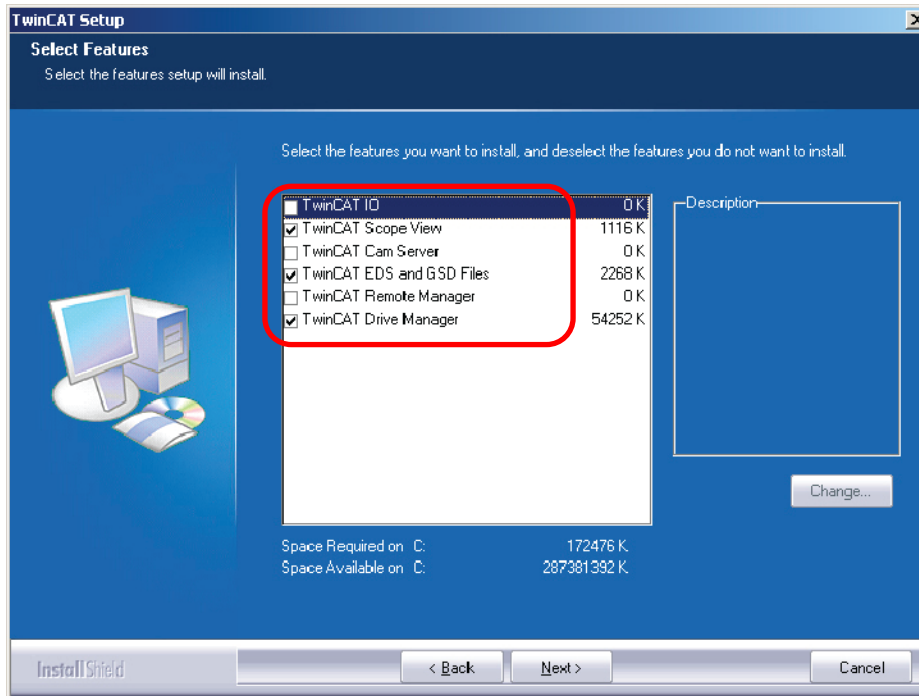

TwinCAT 2 Destination Folder

The default selections are shown below.

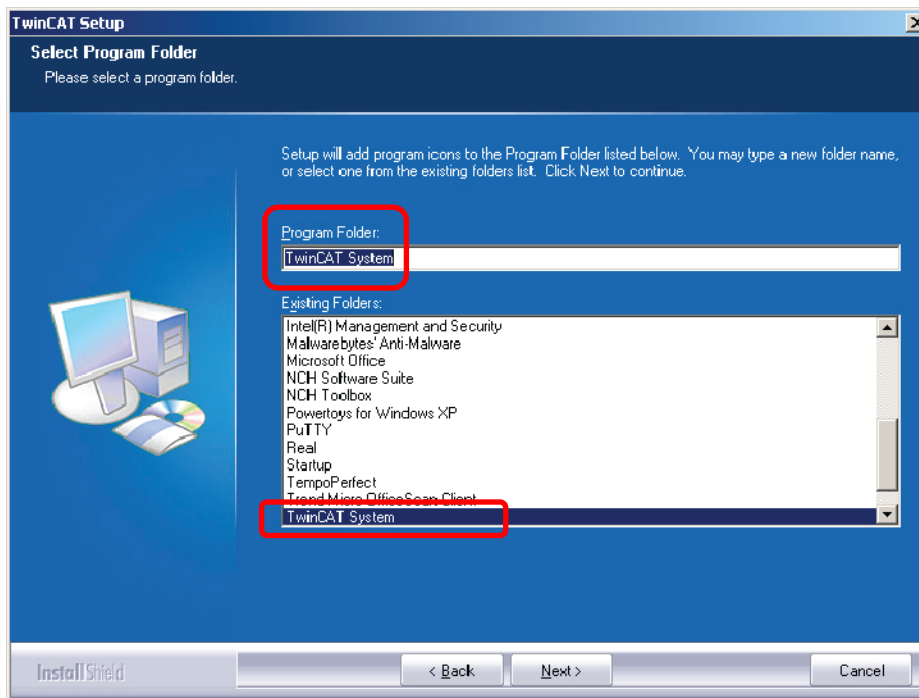

Restart Prompt

Restart is required at this point.

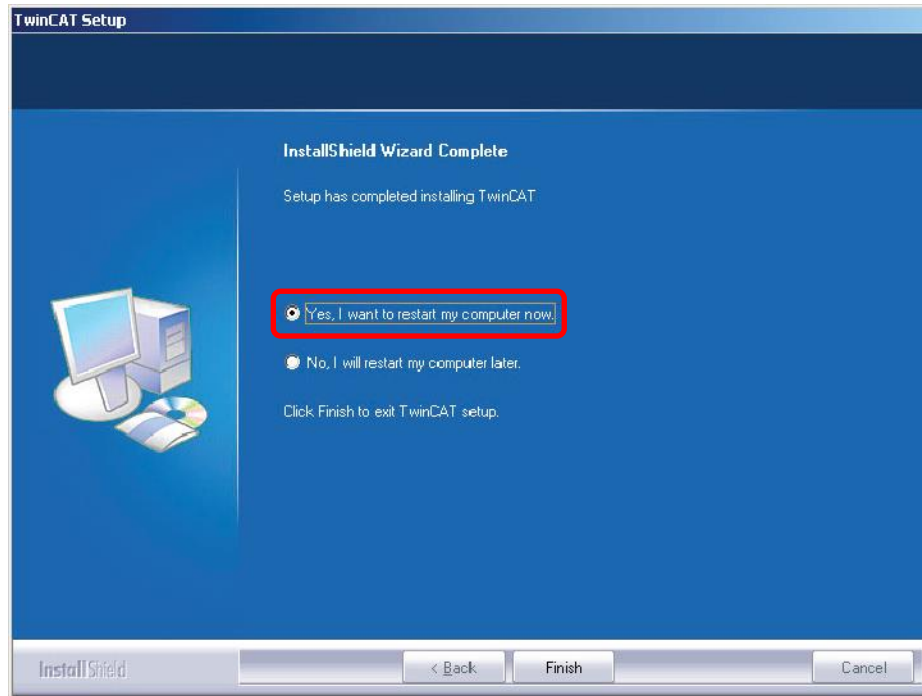

Restart

After restarting, the TwinCAT 2 splash screen will appear:



System Properties

Right-click on the TwinCAT 2 icon in the Windows Taskbar and select Properties.

The Registration tab shows version and trial expiration date info:

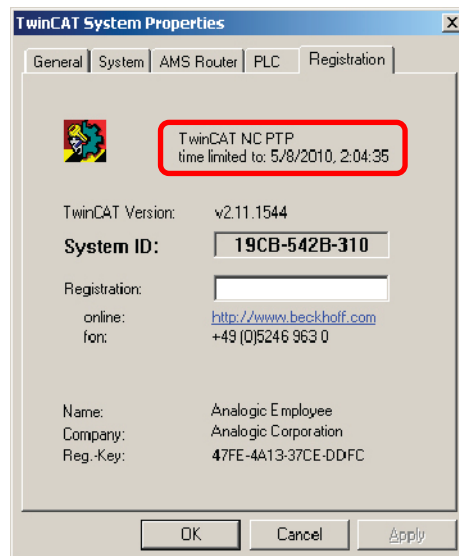

System Properties

The System tab shows the items installed. Note that TcPLC is shown because it was above NC PTP when the installation selections were made.

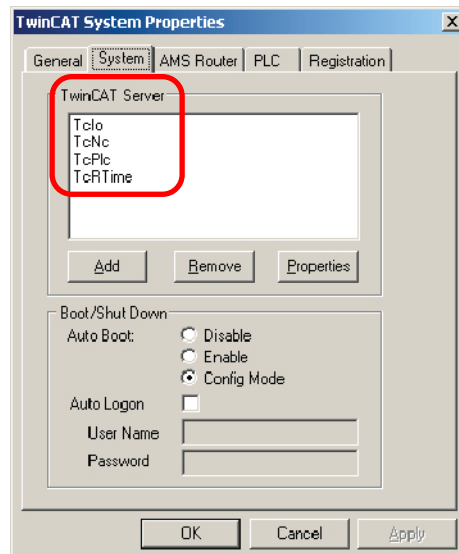

Check ESI File Installation

Download the ESI (XML) files from the Copley Controls web-site and paste them into the c:\TwinCAT\IO\EtherCAT folder. TwinCAT 2 will scan this folder for devices when it is launched so if it's already open, then close it and re-launch.

Also, be sure that there is only one ESI file for each Copley Controls device type in the IO folder. TwinCAT 2 only allows one ESI file for any device type in this folder. The example below shows ESI files for the Accelnet Plus EtherCAT (AEP) and Xenus Plus EtherCAT (XEL) devices.

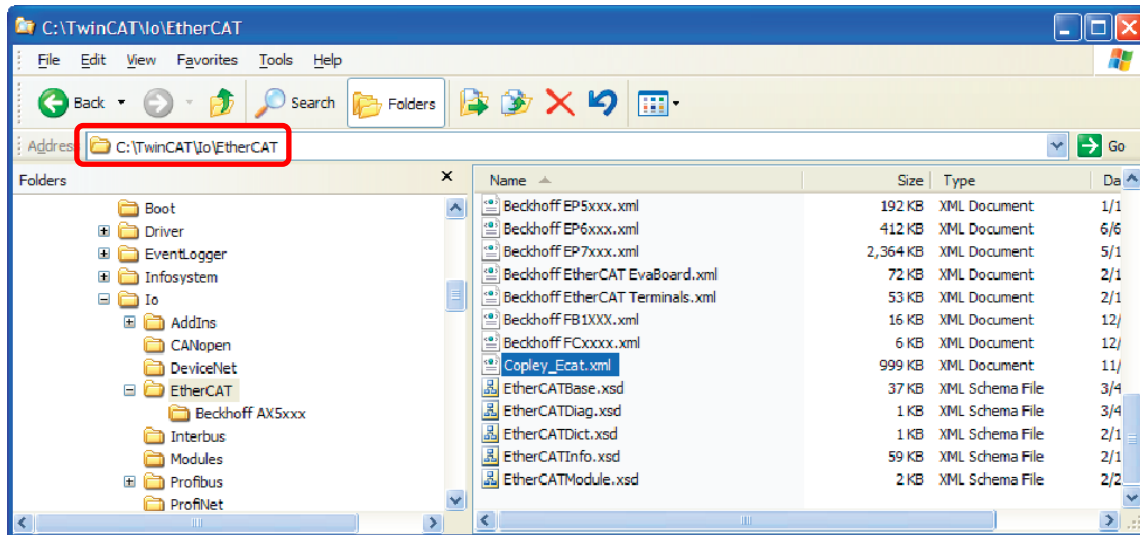

Installation Is Complete

At this point, TwinCAT 2 is installed, the Copley Controls ESI files are in the proper folder, so it's time to begin setting up a Copley Controls EtherCAT servo drive in TwinCAT 2.

Launch TwinCAT 2 System Manager and this is what appears.

Right-click on I/O Devices in the folder window

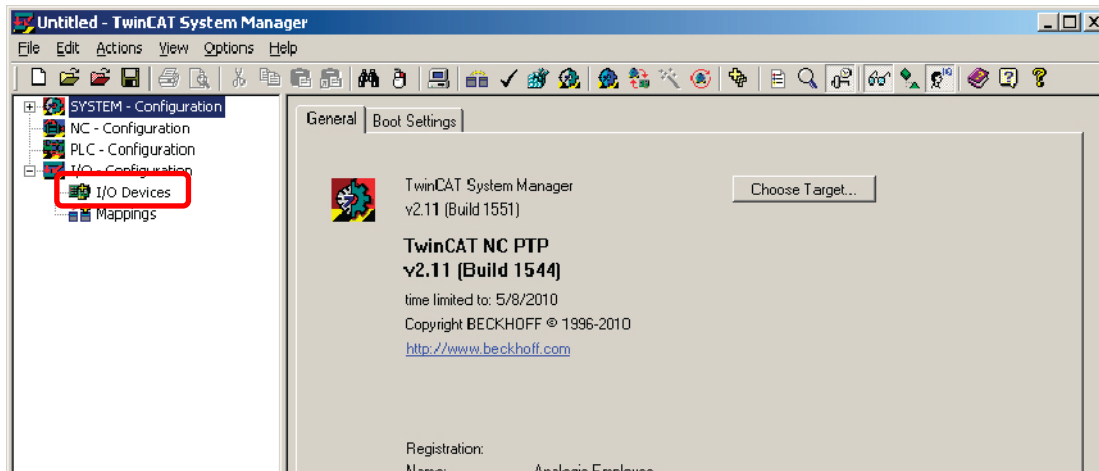

Open A New File And Scan For Devices

From File -> New, or click the icon, create new TwinCAT 2 project.
Next, right-click on the I/O Devices folder and select Scan for Devices.
The pop-up gives a warning but click **[OK]** to proceed.

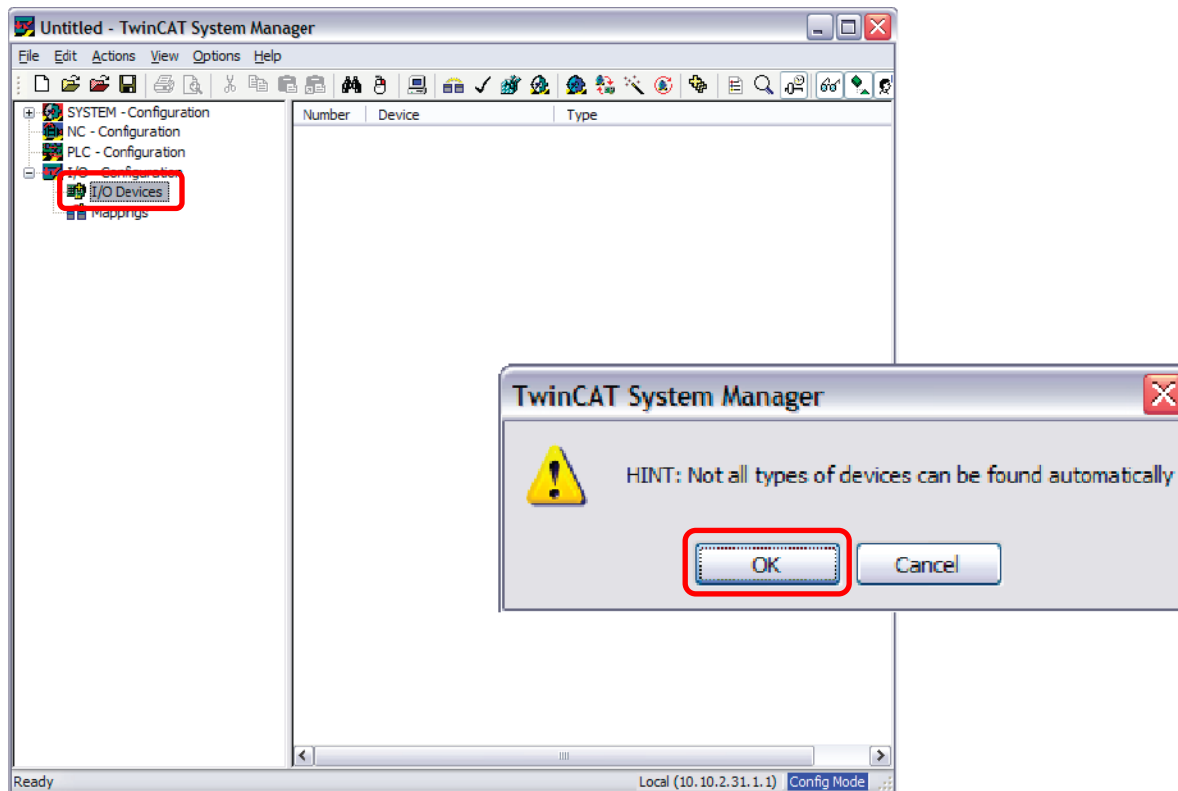

Select The Nic For Ethercat

Click **[OK]** for the EtherCAT port, Scan for Boxes,
Click **[Yes]** to Add drives to NC-Configuration,
Click **[Yes]** to Activate Free Run.

Devices Found And Link To Nc Controllers

If all goes well... TwinCAT 2 should find the CC devices and link these to NC controllers. Expanding the folder tree to show the NC and XEL items, we can see the encoder and outputs of the NC and the PDOs that have connected them.

NC Controller Detail

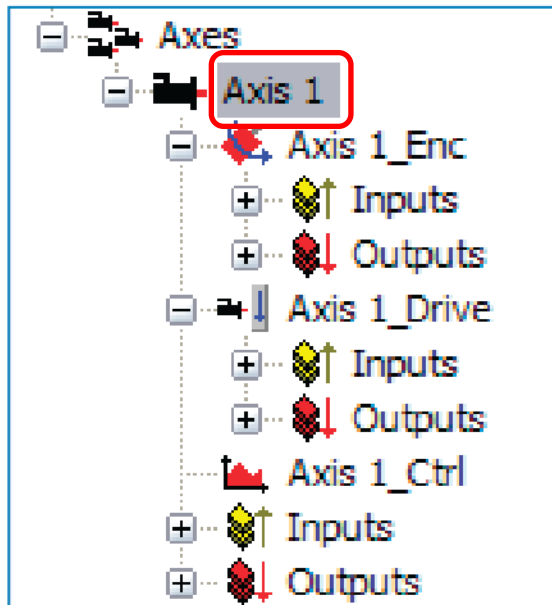

Copley Drive Detail

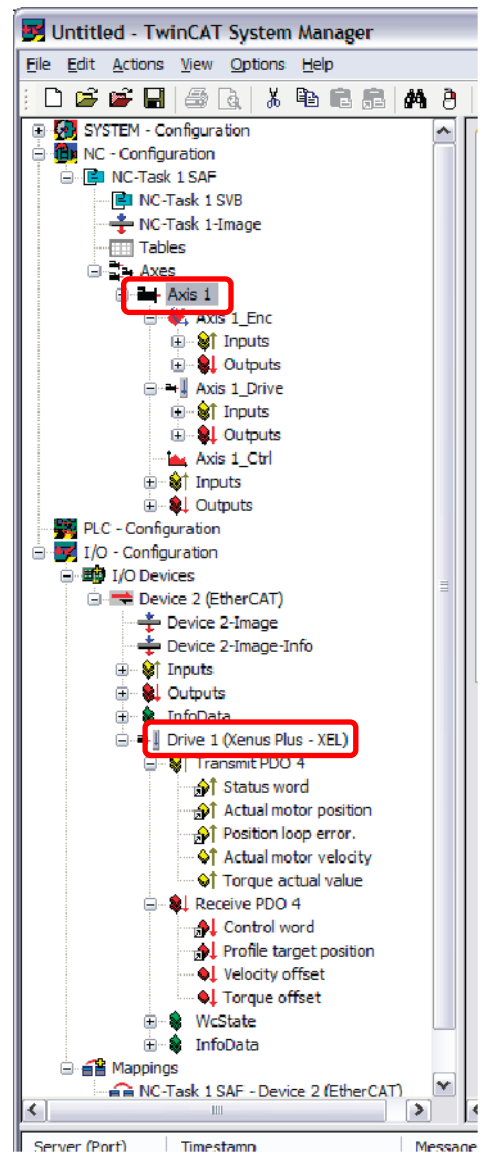
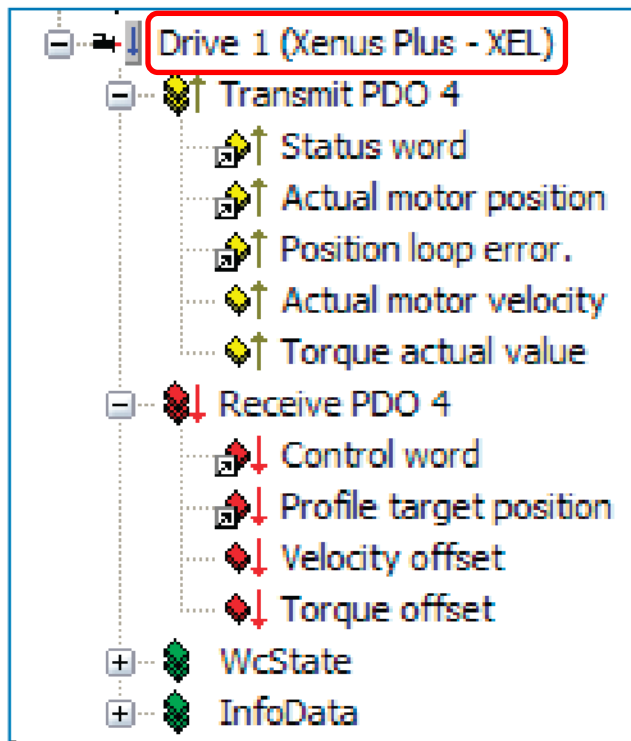

Data Linkage In TwinCAT 2

The diagram below shows how the servo drive is “wired” to the TwinCAT 2 NC using PDO data.

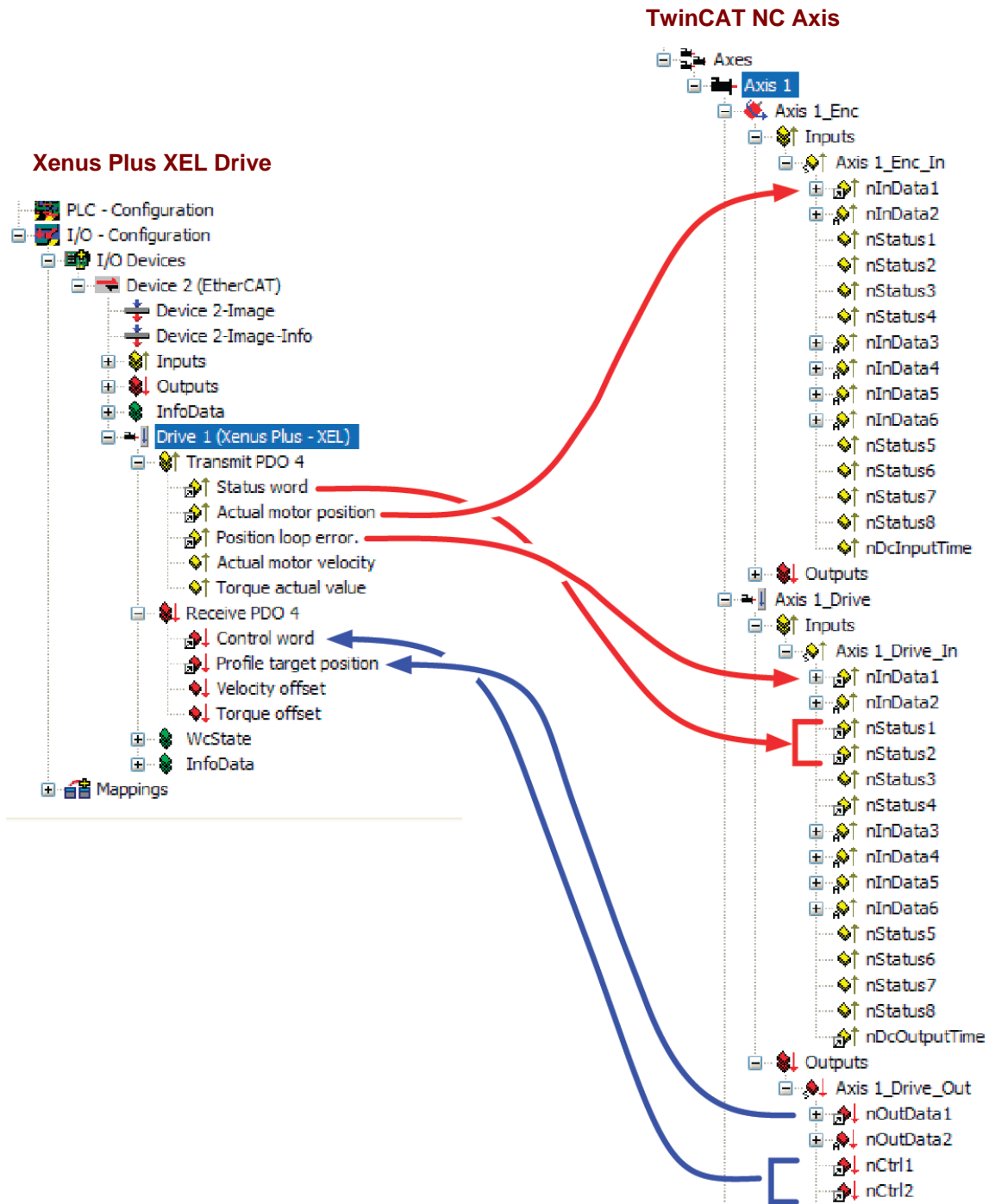

NC Configuration

As a position profile generator, the TwinCAT 2 NC must first have the *units* of position measurement configured. In the NC encoder, Axis 1_ENC in this example, Parameter tab the Scaling Factor is the important parameter. This number = (distance to cover) / (number of counts)

For a rotary motor, distance can be one revolution, and number of counts can be the encoder counts after quadrature decoding. For a 1000-line quad A/B encoder, this works out to $1000 \times 4 = 4000$ counts per revolution.

In this screen, the rotary motor has an absolute encoder that gives 131,072 counts/rev.

The units in TwinCAT 2 are shown as “mm/INC”. The “mm” is really a place-holder, not necessarily for millimeters, but for the unit of measurement. In this case it will be motor-revolutions.

So, 1 rev / 131,072 counts = .00007629394.

Click in this box and change the default .0001 number to the one for your motor’s encoder or feedback.

You don’t have to hit the Download button now, this change will take effect when the TwinCAT 2 configuration is “activated” later.

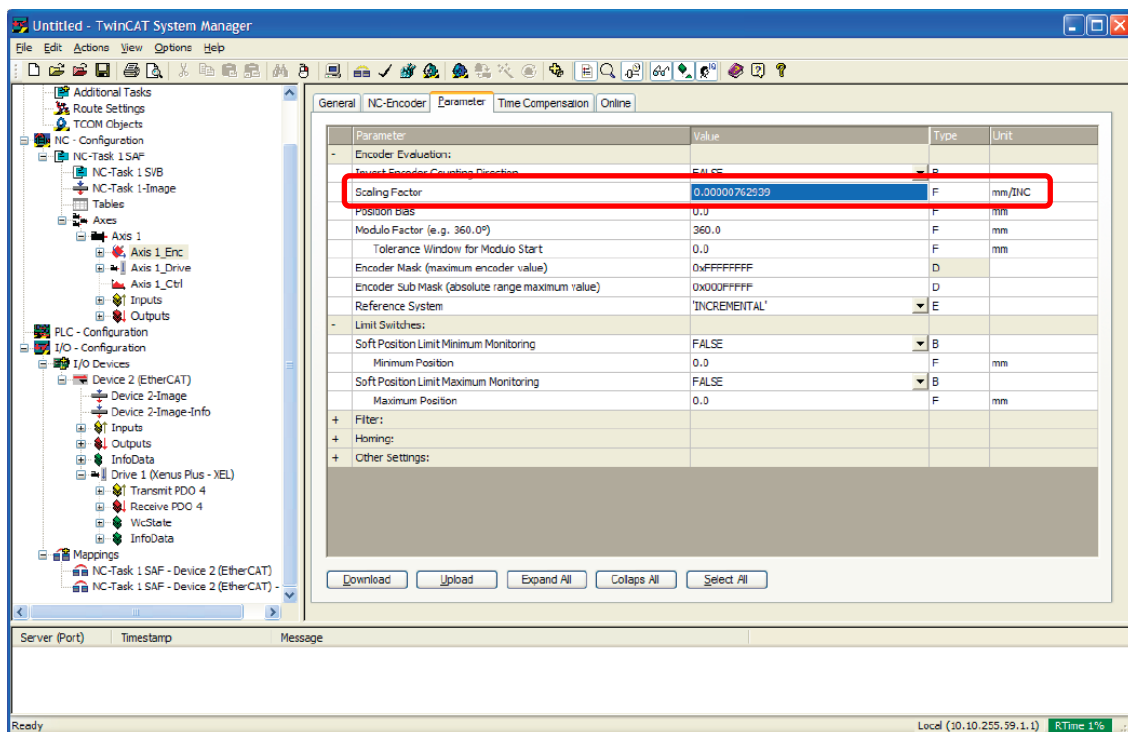

NC Units

If the motor is a linear axis, then the distance to cover might be mm, inches, or metres. All of these can be used and will be seen in the NC on-line screen when movements, jogging, etc. will all be done in these units.

NC Velocity And Fault Configurations

With the feedback units of measure configured, the next step is to set the NC parameters that control the speed of the motor as well as some fault conditions. This screen shot shows the parameters that will be adjusted.

- Reference Velocity: "mm/sec" = units/sec, the same distance-to-measure units that were used in the encoder parameter tab.
- Maximum Velocity: F1-- or F4++ Jog speed (rev/s)
- Manual Velocity (Fast): F2- or F3+ Jog speed (rev/s)
- Acceleration: rev/sec for a rotary motor, or mm/sec for linear (Ref_Velocity / Accel_time)
- Deceleration: rev/sec for a rotary motor, or mm/sec for linear (Ref_Velocity / Decel_time)
- Jerk: $rev/sec^2 = 4 * Accel$ for an S-curve that has the same acc/dec time as trapezoidal
- Position Lag Monitoring: Not needed in NC because position loop is closed in the drive
- Position Range Monitoring: Not needed in NC because position loop is closed in the drive
- Target Position Monitoring: Not needed in NC because position loop is closed in the drive

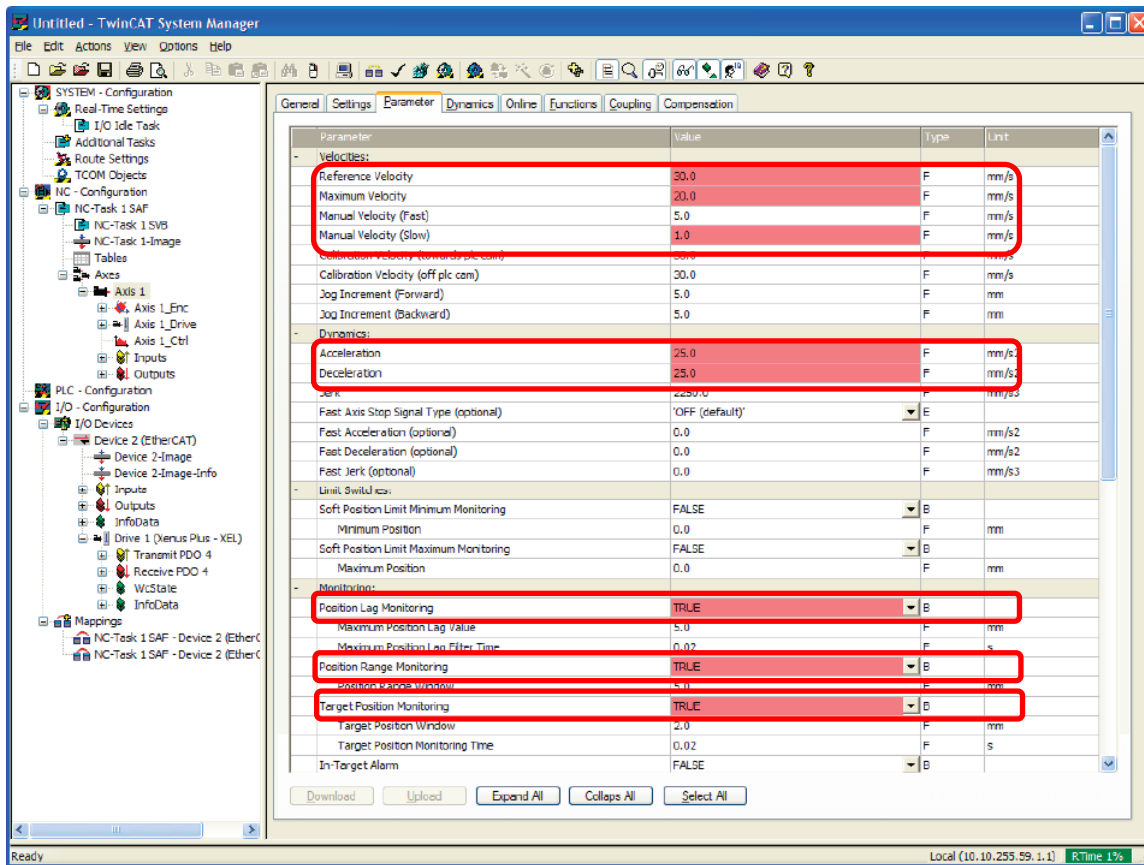

The numbers show in red now and when the configuration is activated will be updated and downloaded to the drive.

Online Operation Of The NC

When the parameter adjustments have been made, it is possible to operate the motor/drive through this control panel:

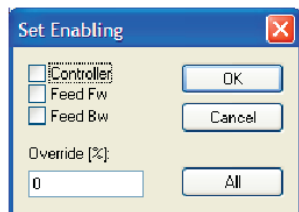
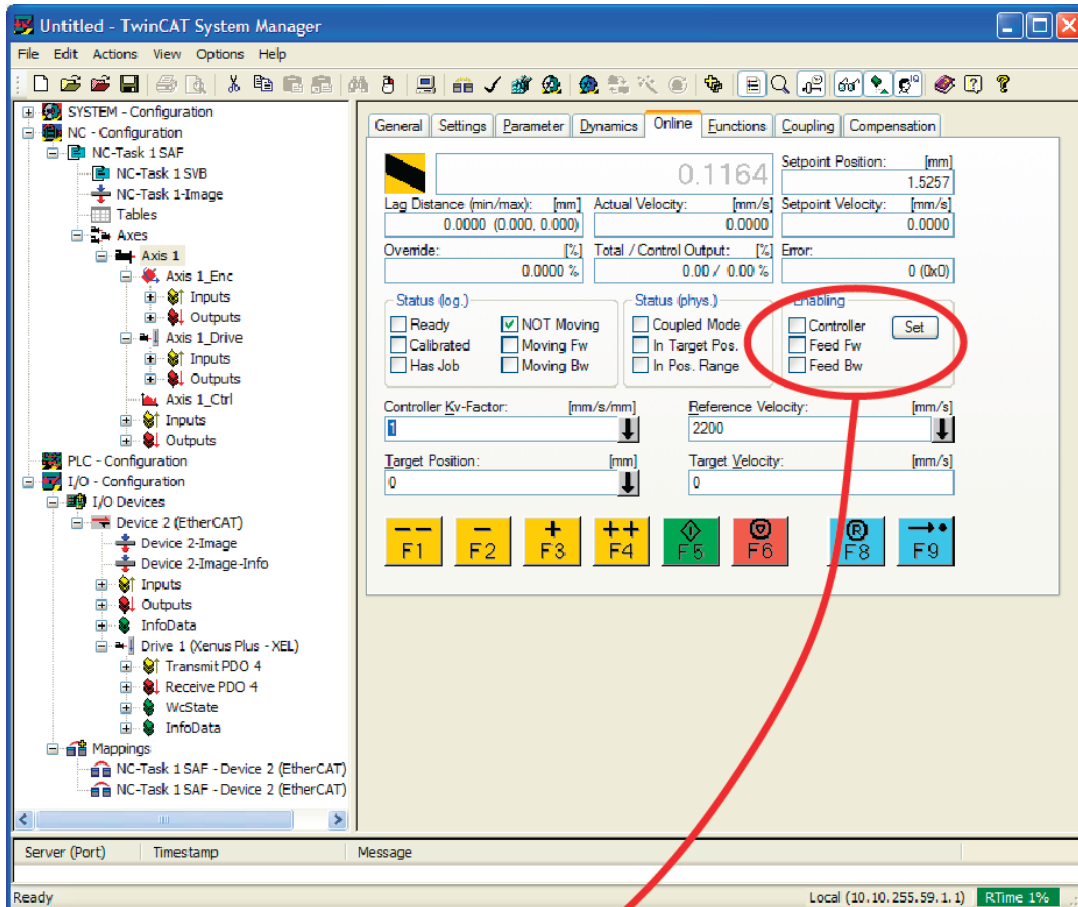

Enable The Drive

Click [Set] and [All] to enable the drive.

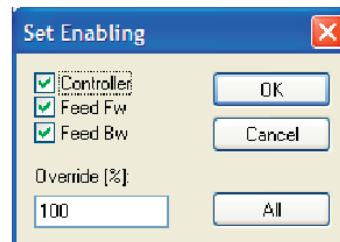

Jogging

The jog keys (F1~F4) should function for fast & slow jogging after the drive is enabled.

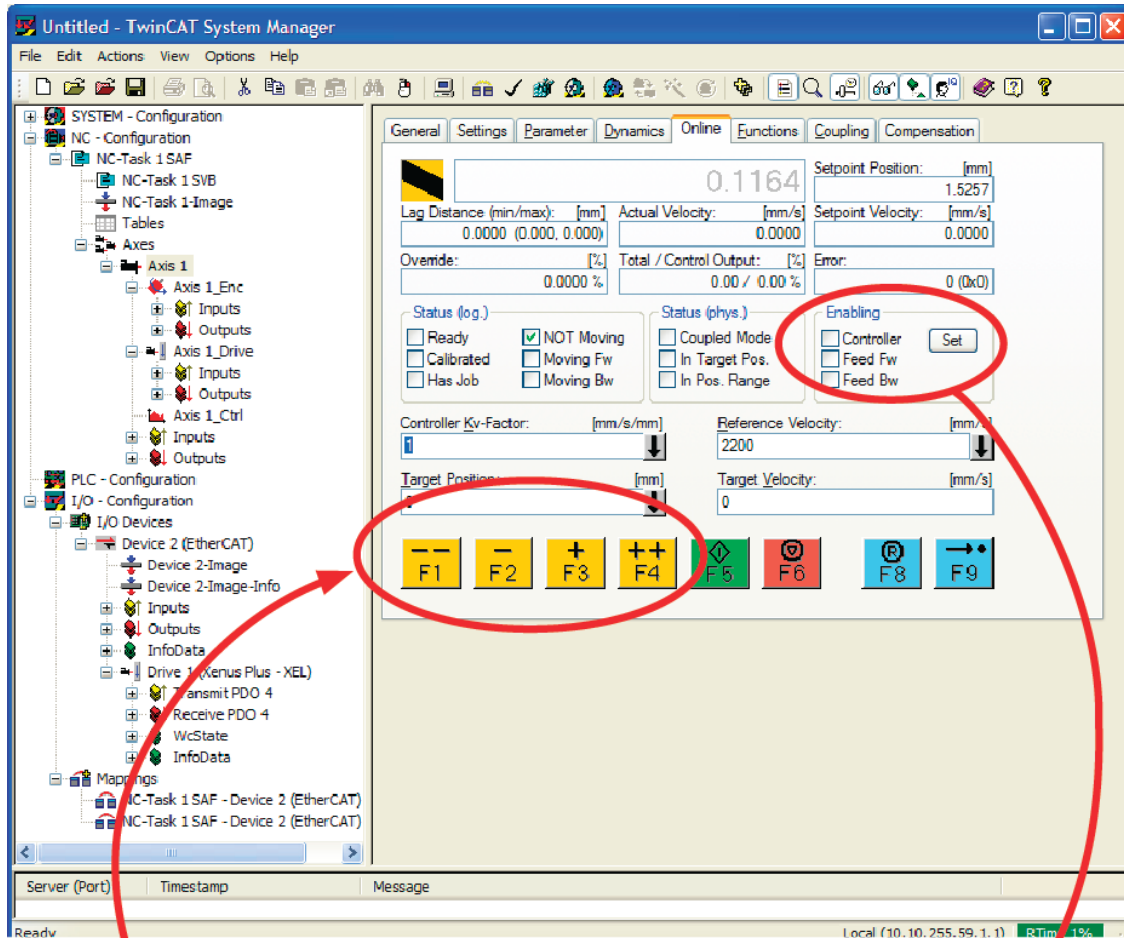

Enable The Drive

Click [Set] and [All] to enable the drive.

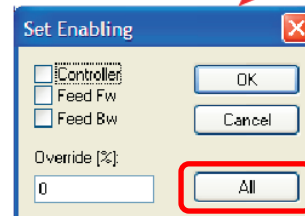
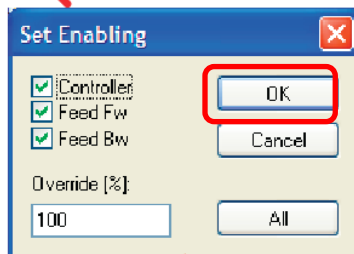

Simple Motion Without A PLC In TwinCAT 2

For tuning or demo, a simple back-forth motion can be made from the NC controller.

First, move the motor to a starting point by jogging, or disable it and move by hand.

Next in the Set Actual Position frame below, click the **[Set]** button with 0 in the position box. The number to the right of the yellow-black box (the actual position) should be zero.

In the Extended Start frame -> Start Mode pull-down, open it and pull-down to Reversing Sequence.

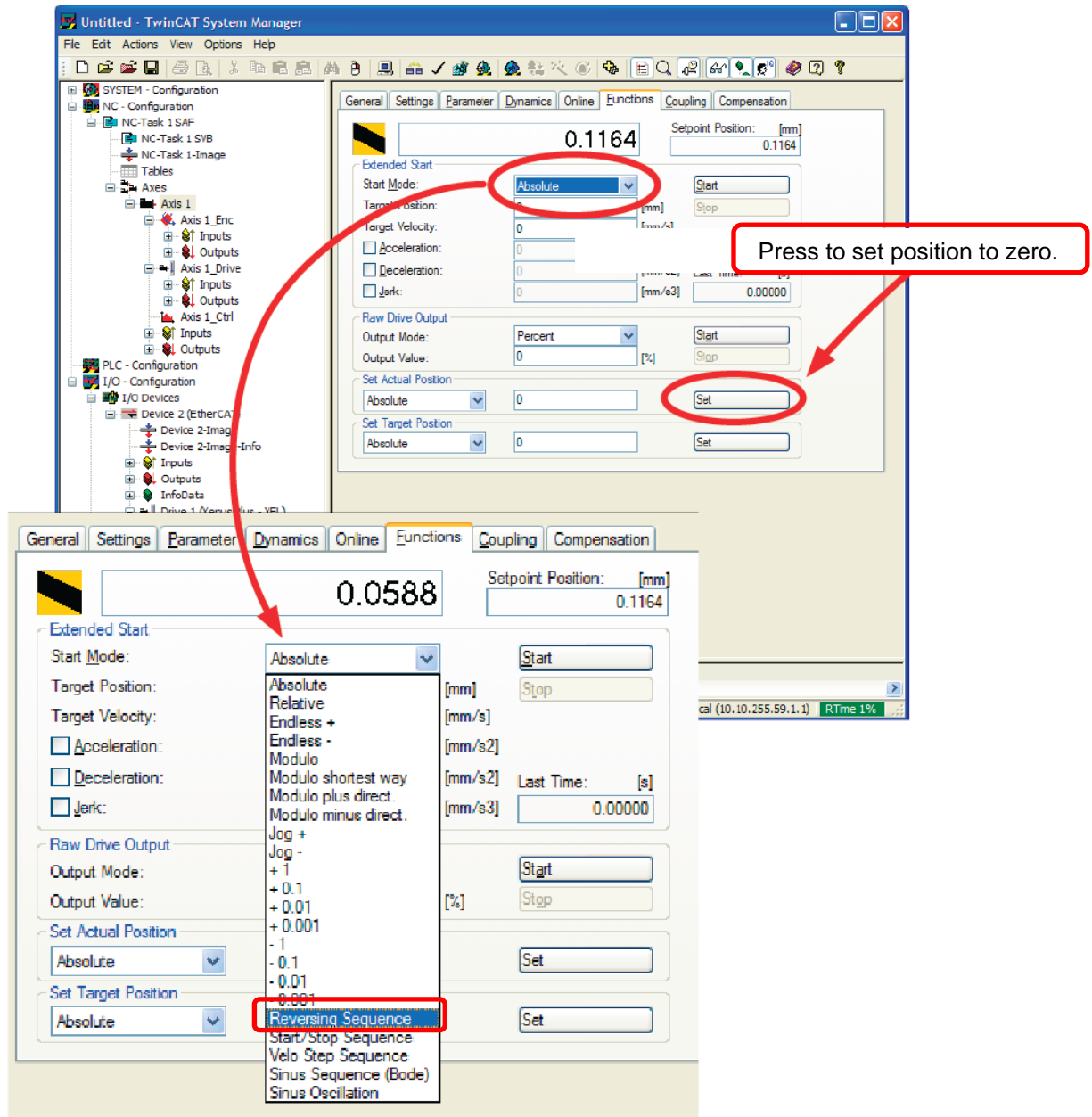

Simple Motion Without A PLC In TwinCAT 2 (cont'd)

From the Reversing Sequence selection set:

Target Position1 = Revolutions for a rotary motor, or mm for a linear to move

Target Velocity = Rev/sec for rotary, or mm/sec for linear

Target Position2 = 0 for an out-back motion from the starting point

Idle Time = Dwell time between moves for the motion to settle

The numbers in this example produce a profile that moves 10 revs at 1200 RPM (20 rev/sec) and dwell for 0.25 sec between moves.

Press the [Start] button in the Extended Start frame to begin and then the [Stop] button will become visible to stop the motions.

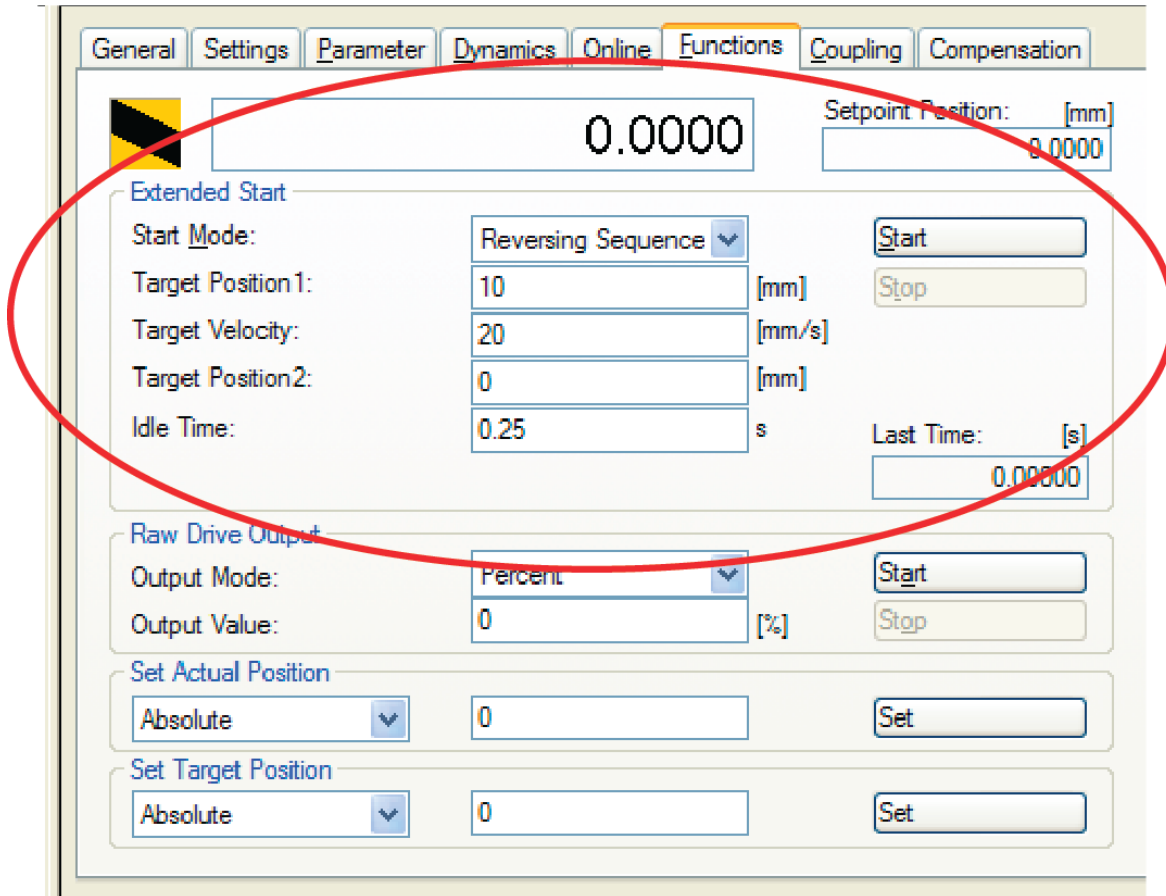

What Next???

A TwinCAT 2 PLC can be designed that provides overall control of the NC & servo-drive combo, I/O modules might be added, etc. But at this point, the TwinCAT master has found the Copley products and can communicate with them over an EtherCAT network while producing simple motion from the NC controller.

Beckhoff

Beckhoff web-site: <http://www.beckhoff.com>

The site is not set up with URLs for every item, so no deep-linking is possible in this document to particular items on the site. But using the menu, information can be found on some useful topics:

Download -> Software -> TwinCAT: This is where to get TwinCAT, 30 Day Demo version.

Download -> Beckhoff Information System -> Reference in HTML format:

The InfoSys is about 300MB, but has much detail on the Beckhoff products, TwinCAT, etc.

6.3 Delta-Tau Power PMAC

Introduction

This section provides information on commissioning Copley Controls EtherCAT servo drives using the Power PMAC Suite software. When these steps are followed, it should be possible to move a servo motor via a Copley Controls servo drive from a PMAC controller. For more advanced motion control it is necessary to consult Delta Tau for details..

IDE Installation

The first step is to download all of the Delta-Tau software and data needed to produce a working PMAC system. This is the primary Delta-Tau web-site page for all the software.

<http://forums.deltatau.com/showthread.php?tid=152>

Click on **File Depot**, and when the screen opens, click on **Power PMAC > Power PMAC IDE**

<http://forums.deltatau.com/filedepot/>

Click on the **Release** link. The most recent version of the IDE will be at the bottom of the listing that is shown.

http://www.deltatau.com/DT_Products/SoftwareDevelopment.aspx

Download the latest release of the IDE.

For the latest PMAC firmware, go to this link. First-time users can click **Login – Register** to get a password to the firmware downloads section.



Under the **Forum Announcements** section, click the links for the **Firmware** and IDE items to download.

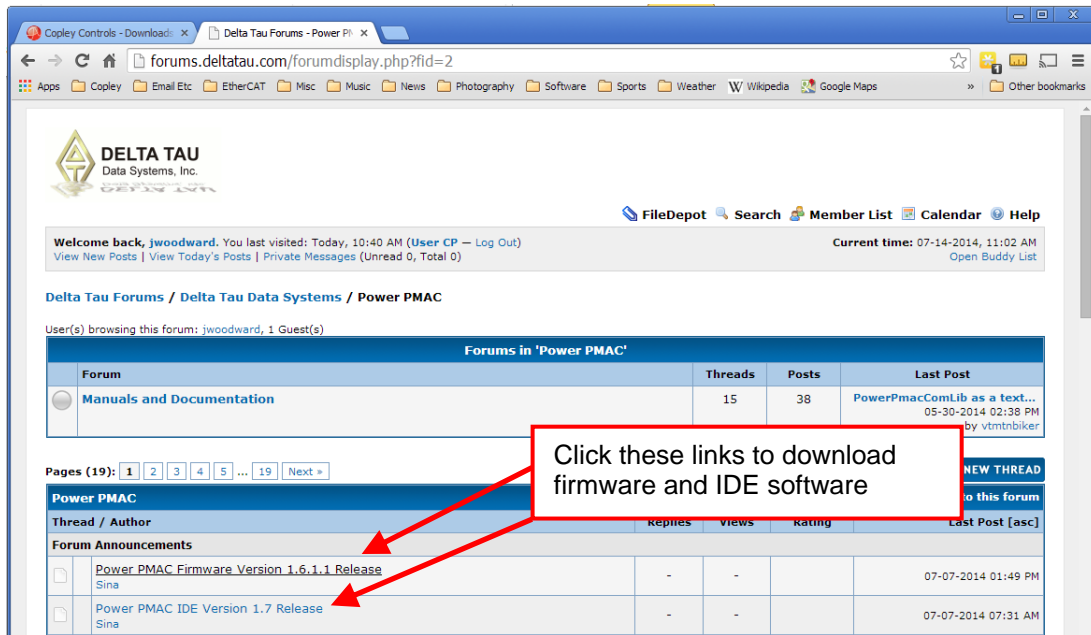

The firmware is in the **Power PMAC -> Firmware** folder and the IDE is in the **Power PMAC IDE -> Release** folder. Unzip these files after downloading and setup the IDE on your computer.

Do not launch PowerPmacSuite.exe until the Copley ESI files have been installed.

ESI (XML) Files

Go to the Copley Controls web-site, **Downloads -> Software Releases -> Firmware & EDS/ESI(XML)**
 Next, **Firmware & EDS/ESI Downloads -> EDS/ESI** and click on **EtherCAT**
 Save the file *ecatxml.zip* to your computer, and then un-zip it to extract the files.
 This will produce two folders: “flat” & “slots”. Copy all of the ESI files from the **flat** folder into the PMAC **ECATDeviceFiles** folder as shown below:

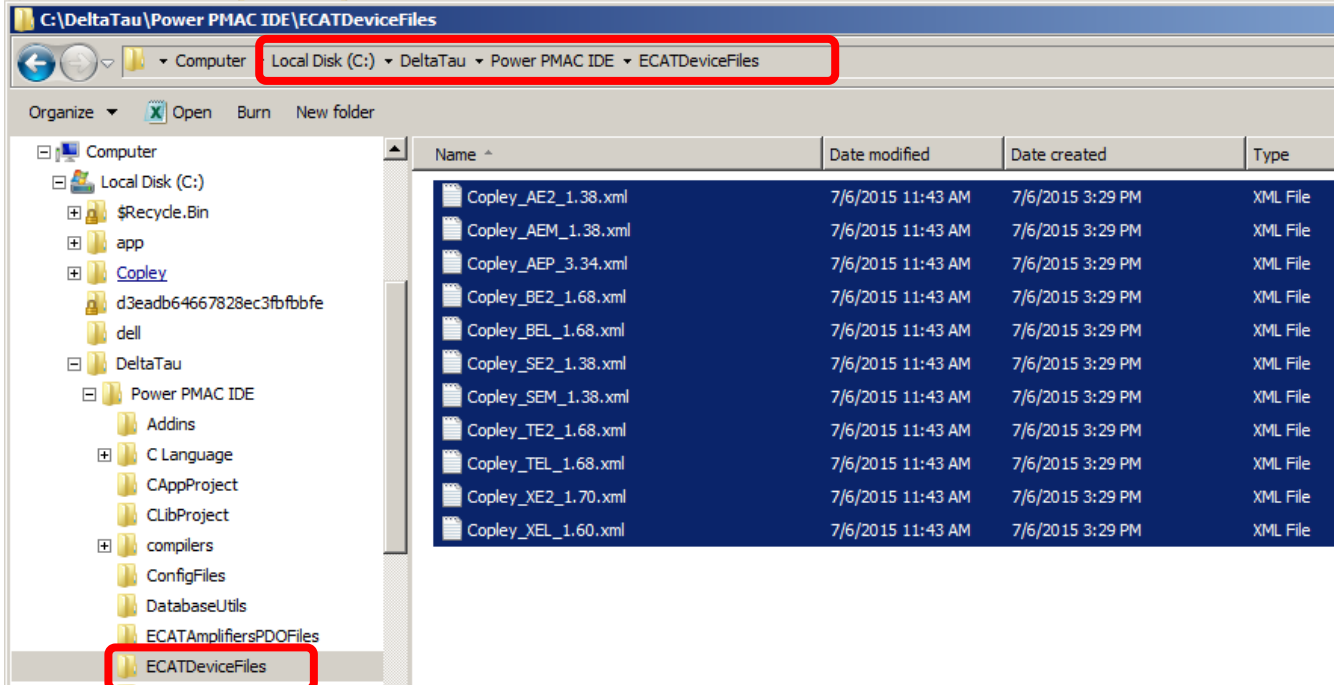

Launch the Power PMAC IDE



Local Network Configuration

Connect an Ethernet cable between the *Eth 0* port of the PMAC and the NIC on your computer. The PMAC can also operate through an Ethernet switch. Open the **Windows Control Panel** and select **Network and Sharing Center** from the listing. When that screen opens, click on **Change Adapter Settings**. Select the adapter to be used for EtherCAT operation

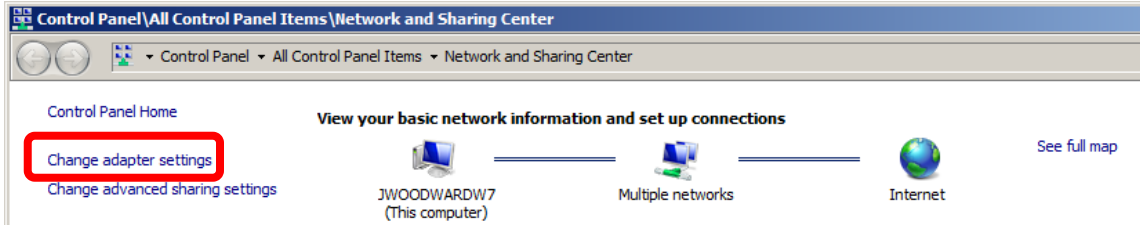

Select the local port to be used and open it:

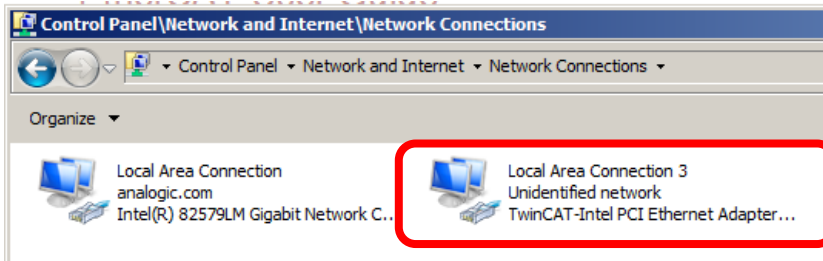

When the port screen opens, click [Properties]. The PMAC requires TCP/IPv4 so make sure that there is a check mark in the box for that protocol. Click on the IPv4 to make it highlighted, then press [Properties]:

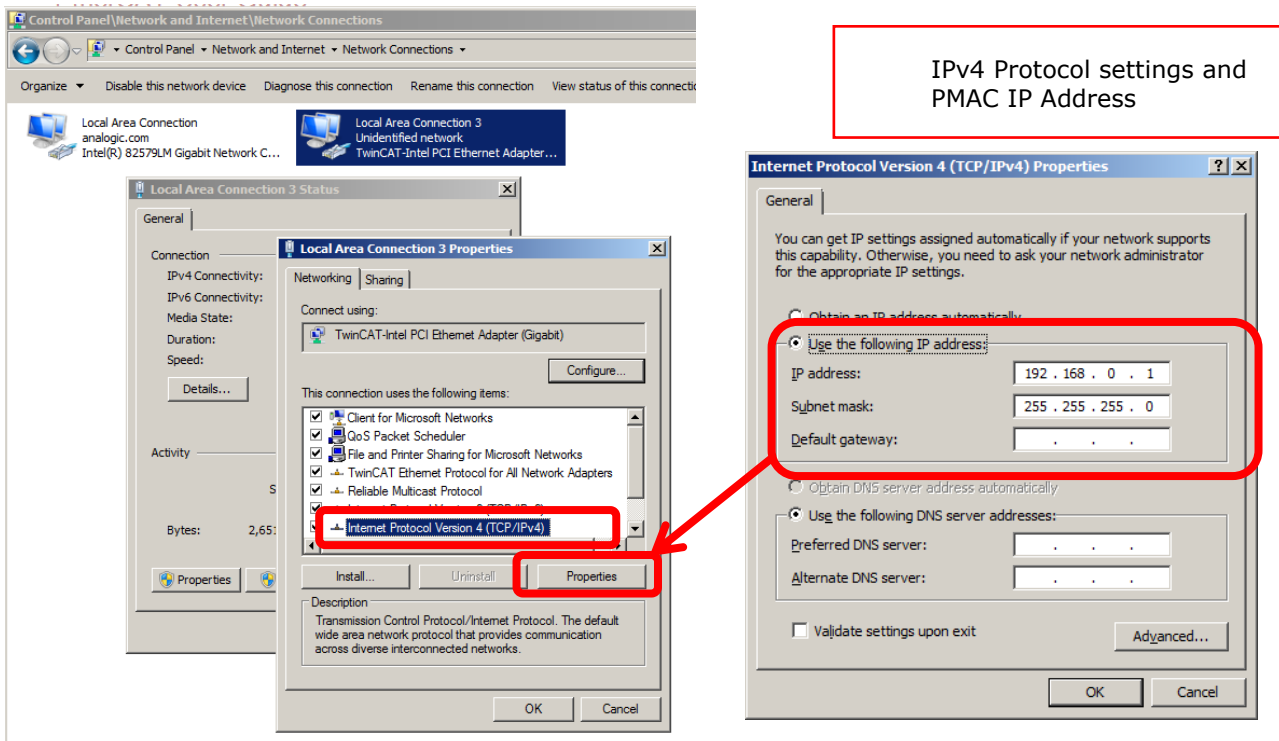

Set up the IPv4 properties as shown above. This is the default setting for the PMAC network port. If the PMAC has been set up with a different IP address, then enter that in this screen.

From the PMAC IDE select **Tools -> Options -> Power PMAC**.
 This screen shows the identity of the Power PMAC on the network.

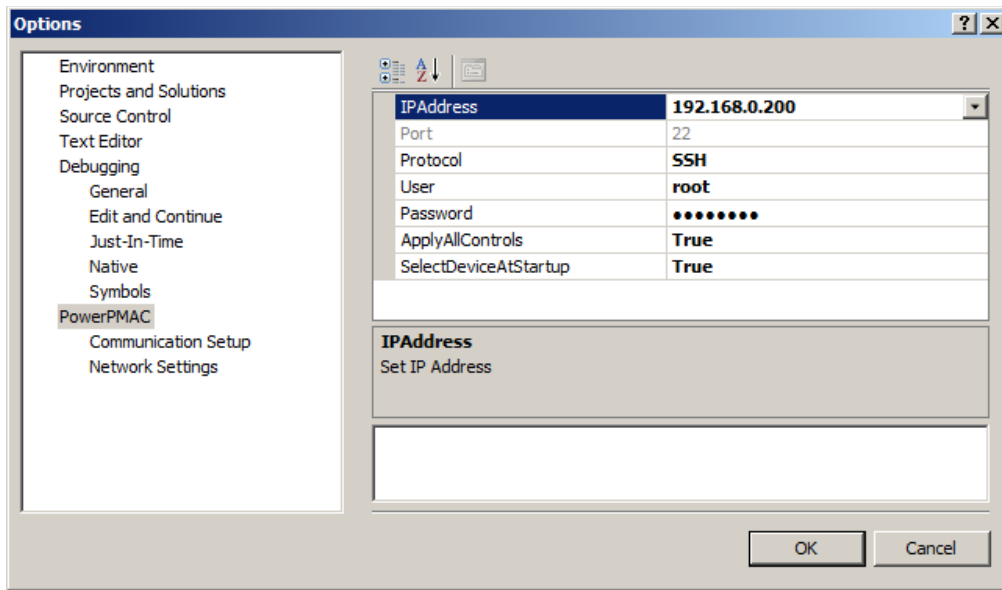

If connection to the IDE is successful, then open the IDE to the main page now.

Updating Firmware

Check the PMAC firmware version from the IDE with **Tools -> Task Manager -> Firmware Version**:

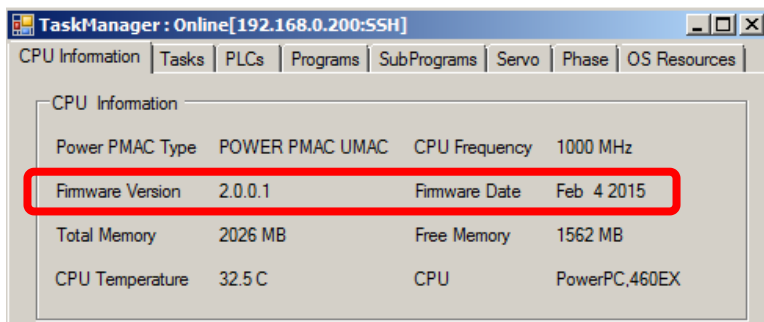

Check the version number of the firmware that was just downloaded. If it is higher than the firmware version as shown in the **Task Manager > CPU Information**, then install it now.

Open this screen: **Power PMAC -> Delta Tau -> Configure -> Download Firmware** and follow the instructions.

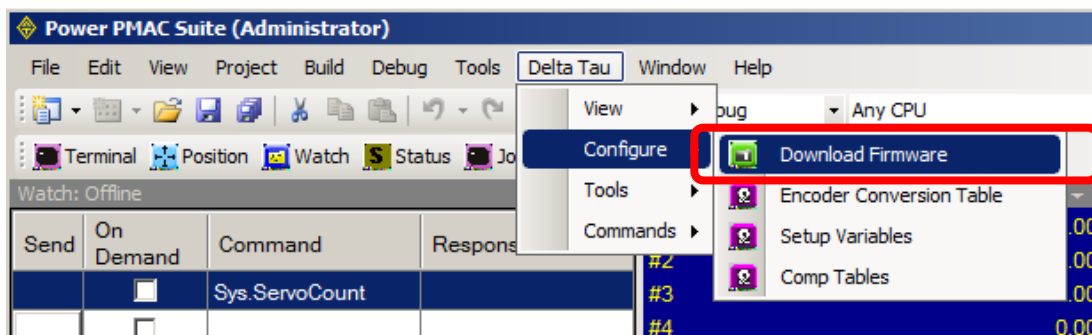

Start a new PMAC project

On the main page, click as shown to create a new PMAC project.
Power PMAC Suite -> File -> New -> Project

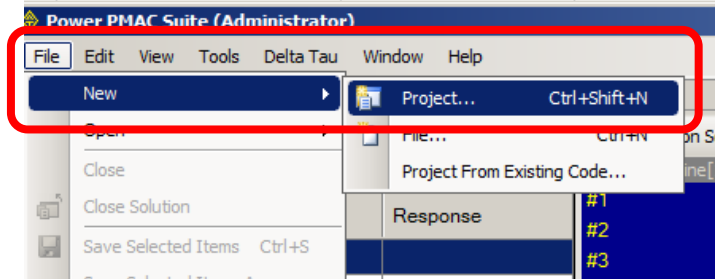

This will appear briefly
 Click **[OK]** to continue:

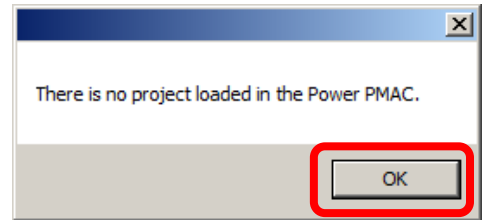

Name the new Project and click **[OK]**

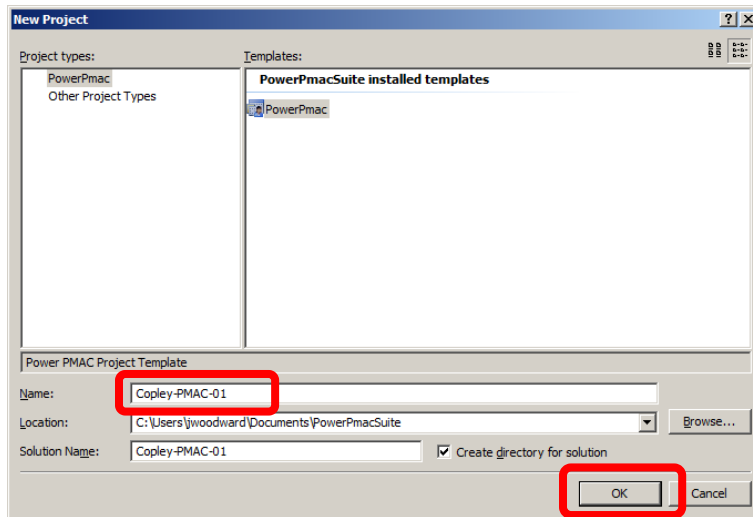

Reset the Power PMAC

This will “wipe” the PMAC and will prepare it for a new and complete configuration.

Using the Terminal Window, reset the PMAC flash memory to factory settings.
 This will erase any settings that may be in the PMAC flash from a previous configuration
 Enter: **\$\$\$*****. This clears RAM and loads the factory settings from flash to RAM.

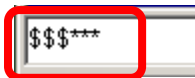

Next, enter: **save**. This copies the RAM settings to flash, overwriting any existing settings.



Re-boot from flash, loading the factory settings to RAM



System Setup

Open System Setup: **Power PMAC -> Tools -> System Setup**

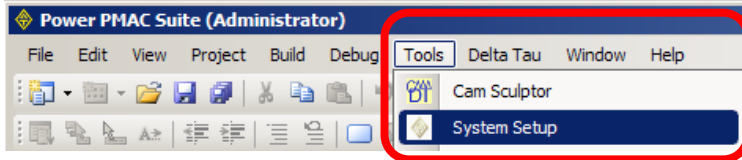

This is the screen after **System Setup** opens.
Note that the PowerPMAC is highlighted as the default selection.

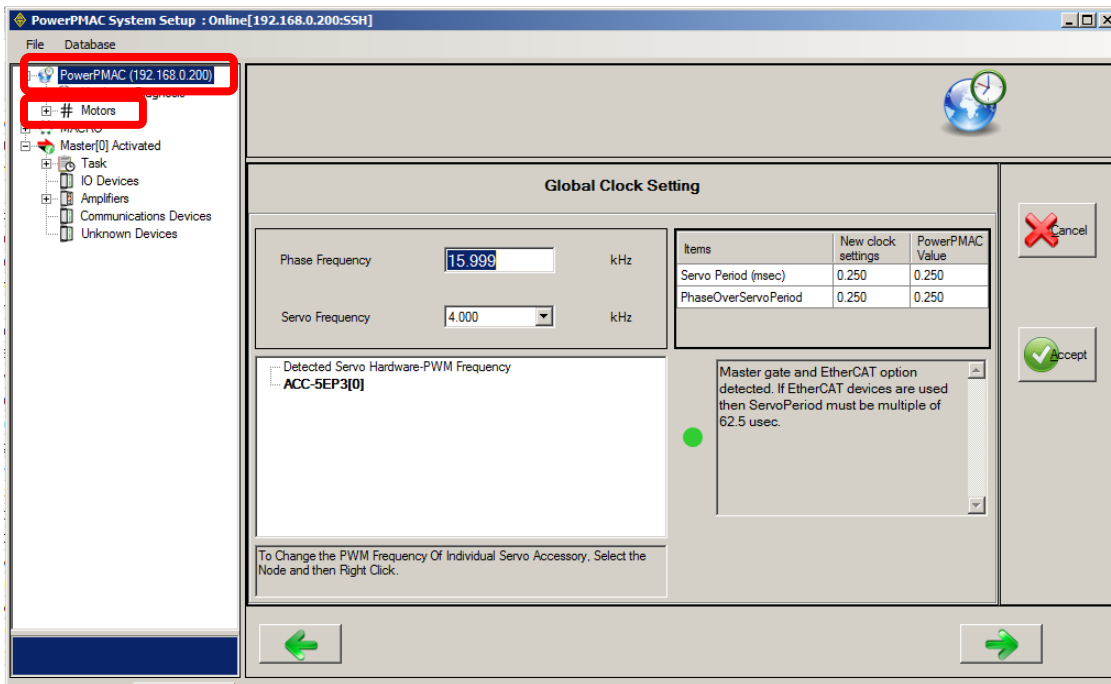

Create a New Setup

In System Setup, select **New -> Setup** to clear any **Motors** that it contained.

Click through the next two prompts:

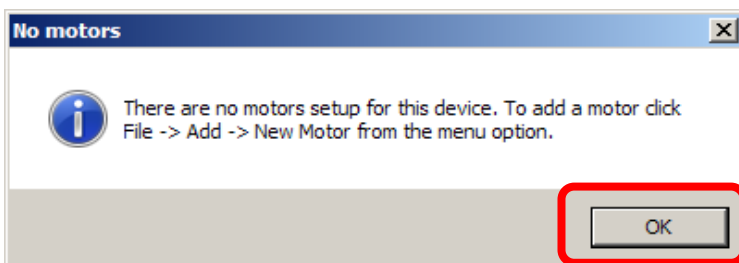
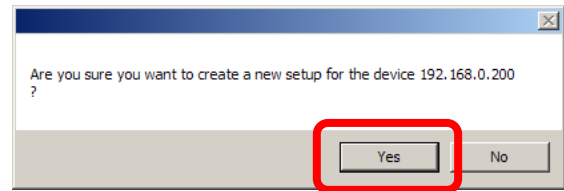
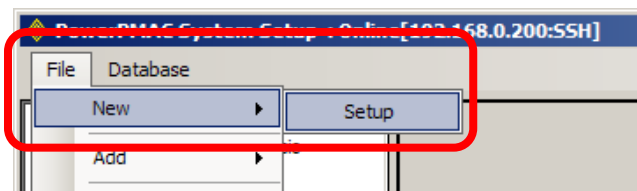

Reset All Masters and Scan for New Devices on the EtherCAT Network

Right-click **Master[0] Deactivated** to open a menu and select **Reset All Masters: Power PMAC -> Master[0] -> Reset All Masters**. Click **[Yes]** when prompted. Then select **Scan Devices**. Follow this with **[Yes]** to reset scan devices on the network.

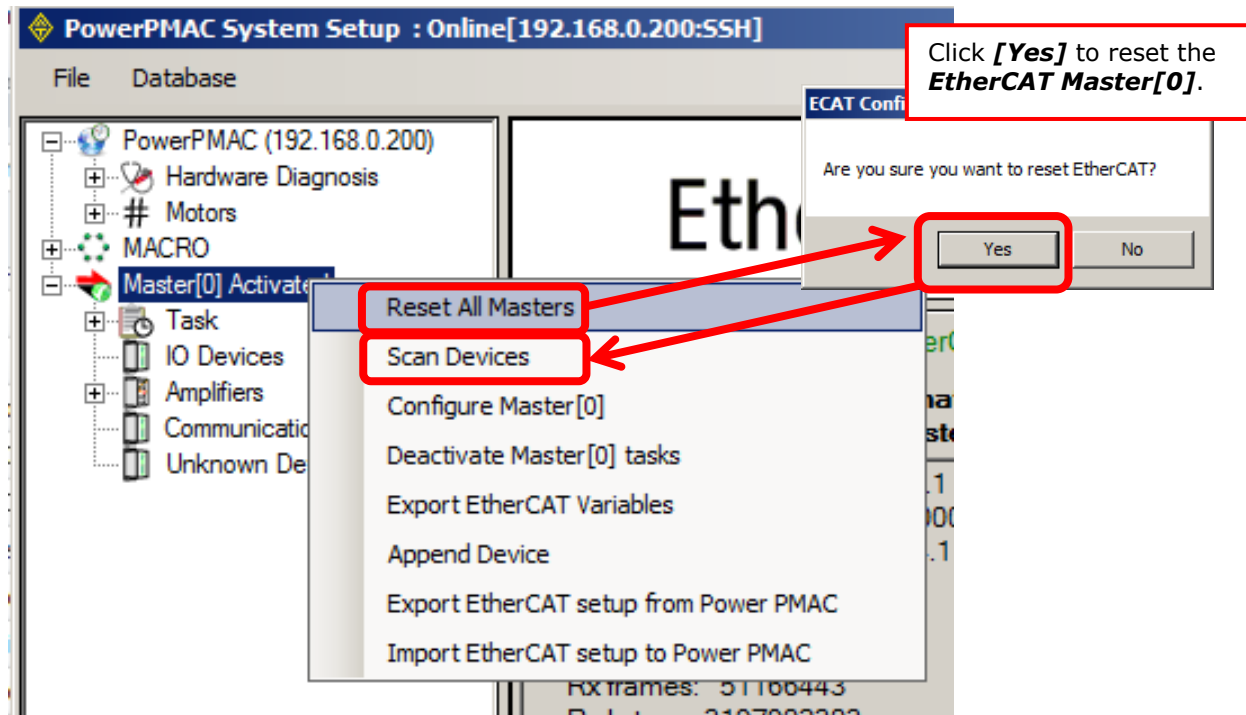

Set System Clock Frequencies

Set the global clock frequencies to work with the Copley drive. **Power PMAC -> Global Clock Setting Phase Frequency** (Copley PWM frequency) is set to 16.000 kHz and the **Servo Frequency** (Servo loop frequency in Copley drives) is set to 4.000 kHz. Click **[Accept]** when done..

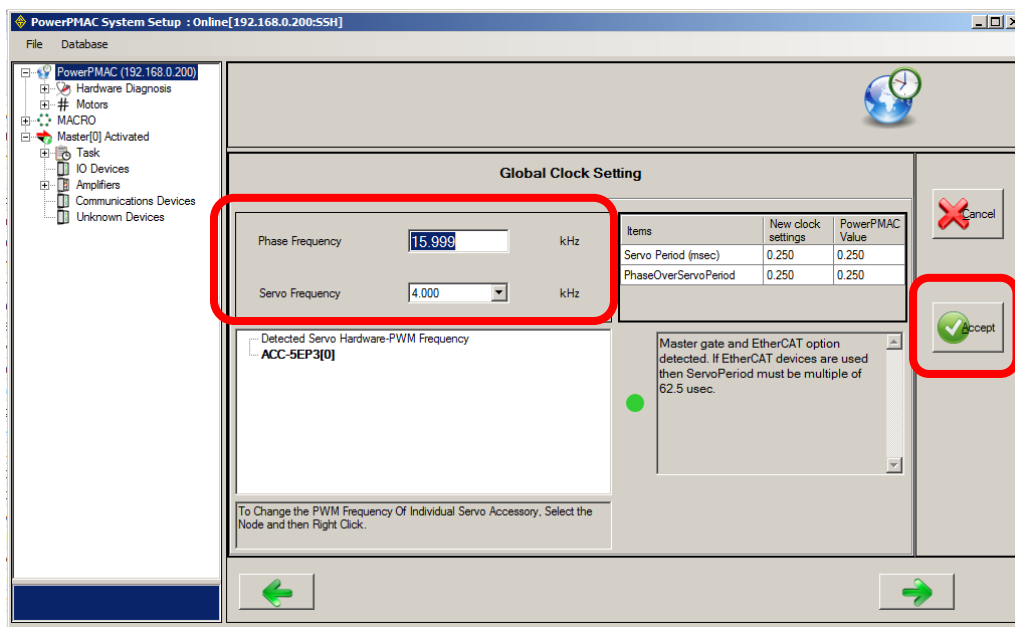

Update Device Files

After the reset, the master will scan the network for EtherCAT devices.
 The Copley drive should appear under the **Amplifiers** section of the **Master[0]**:
 Right-click on the first device and select **Update Device File**:

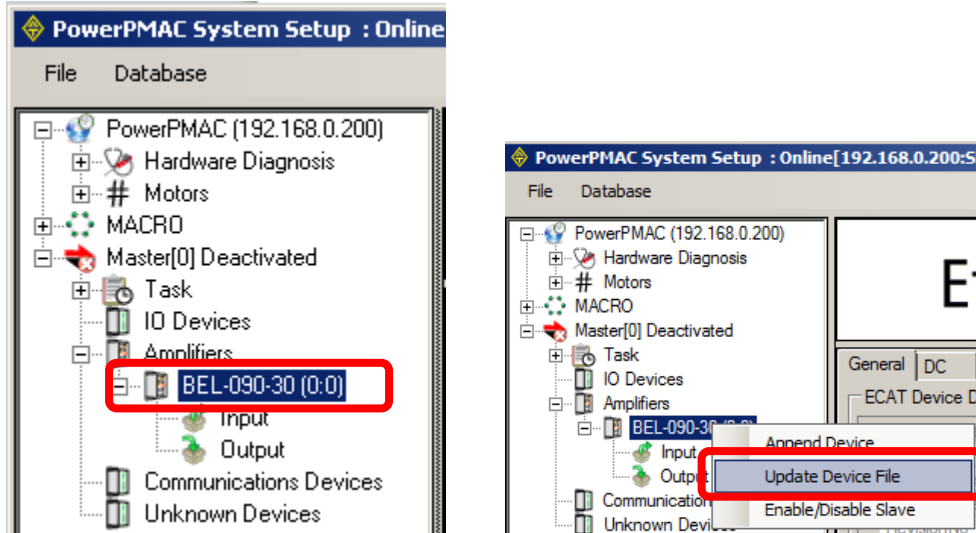

The frame at the top of the screen below shows the data for the selected device. Notice “BEL” in the **Device Specification File** item. Open the file of the same name in the folder tree below and click to open until **Accelnet EtherCAT Drive (CoE)** is shown. Click to select this and the data that shows in the **Device Details** box should have the same Product Code as the drive data in the box at the top. Click **[Update Device File]**:

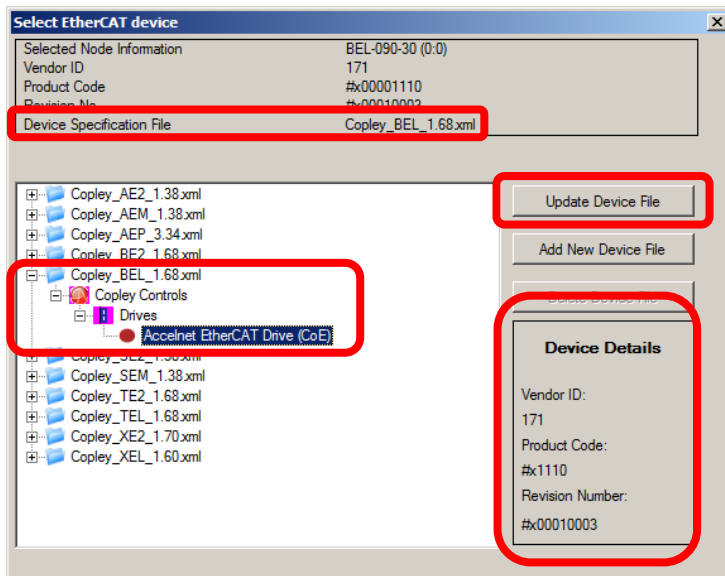

This confirms that the ESI (XML) file has been associated with the matching device.

Click OK, then close the **Select EtherCAT Device** window [X].

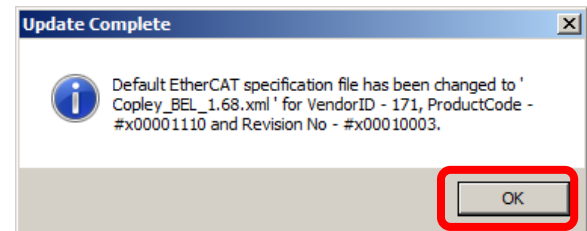

Repeat this action for any other drives that appear under the **Amplifiers** section.

Configure Master[0]

Right-click on **Master[0] Deactivated** and select **Configure Master[0]**:

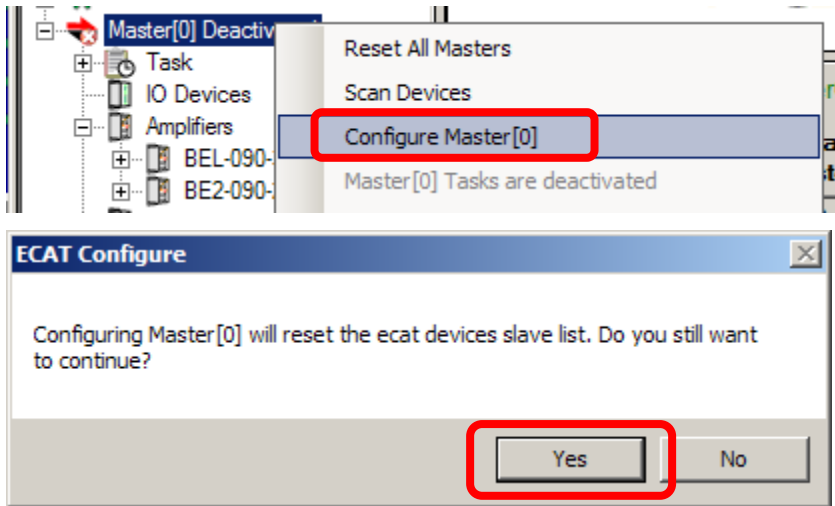

Amplifiers Set Up

General Tab

Click on the first device found under **Amplifiers**, and in the **General** tab to the right will be shown the **Product Code**. In this example is is #x00001110.

Check the **Slave Index**. It must be ≥ 0 . If it is < 0 , then repeat the **Configure Master** step.

If Slave Index is OK, then check **IsDetectedByECATNetwork** and it should be **Yes**.

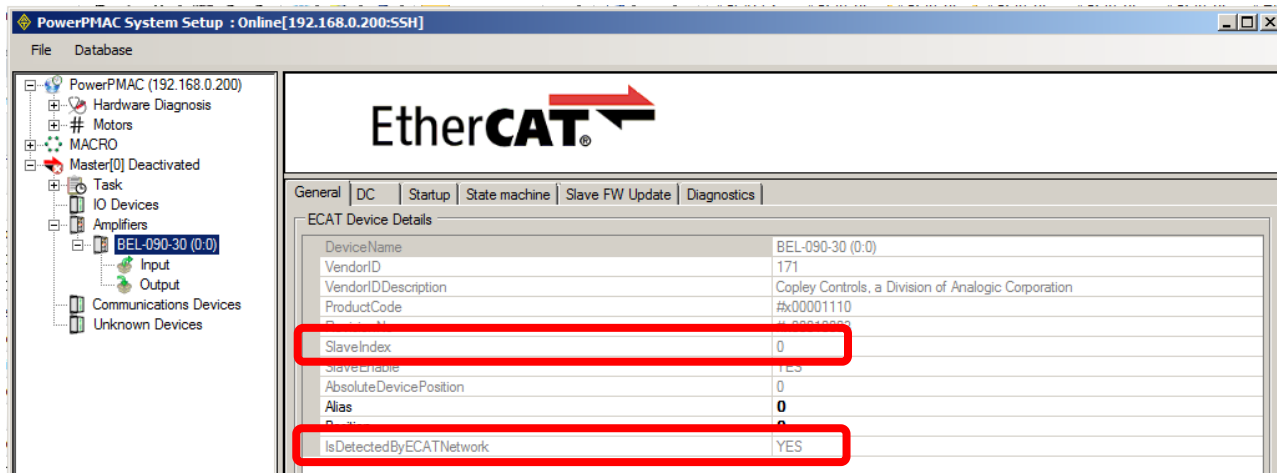

DC Tab

Next, click on the **Amplifiers** device, then on the **DC** tab. For the first device in the network, note that **Is Reference Clock** is checked. The master will synchronize itself and all of the other slaves on the network with the clock of this slave.

Important: When there are multiple **Amplifiers** only one of them can be checked as the **Reference Clock**

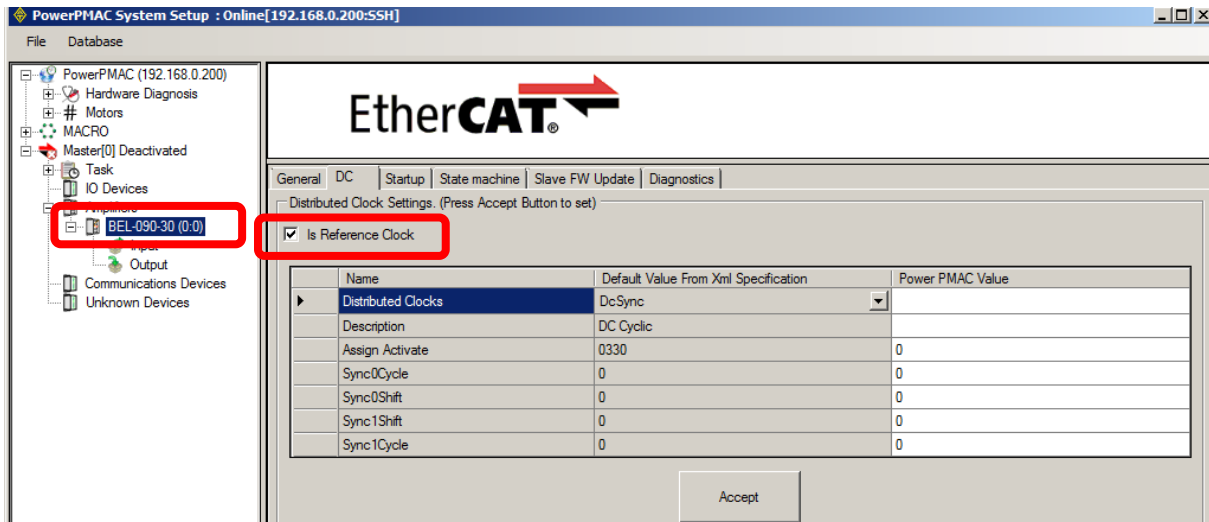

Now, enter data into the **Power PMAC Value** column. The **Assign Activate** value is simply copied from the **Default Value** column. The **Sync0Cycle** time should be the Copley servo drives' position/velocity loop time. That frequency is 4 kHz so the time is 250 μ s, or 250000 ns which is entered in the **Power PMAC Value** column. The **Sync0Shift** time should be one half of that value, 125 μ s, or 125000 ns. Click **[Accept]** to complete this operation.

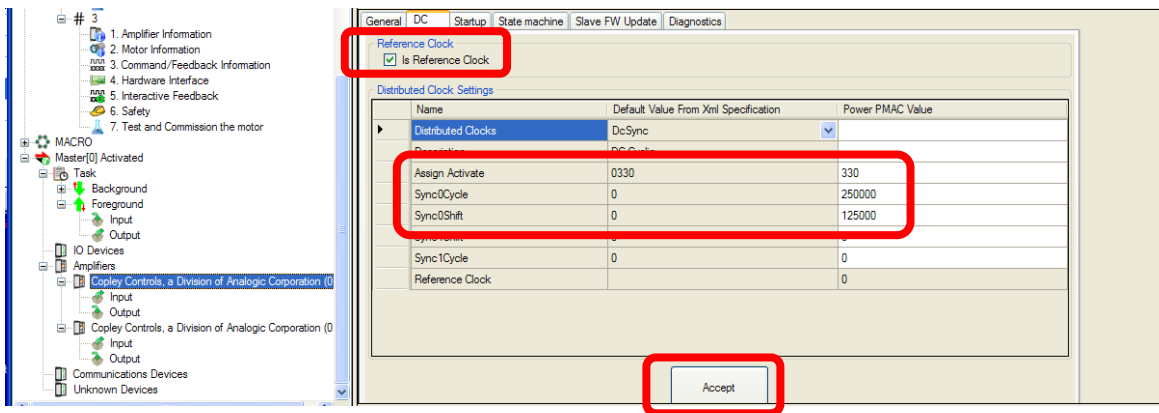

Startup Tab

1-Axis Drives

Open the next tab after the *DC* tab to access the **Startup** mode settings. **Cyclic Sync Position (CSP)** is the default and set from the ESI file. The pull-down listing shows the other Op Modes that are supported. Select **Cyclic Sync Position** and click **[Accept]** to continue.

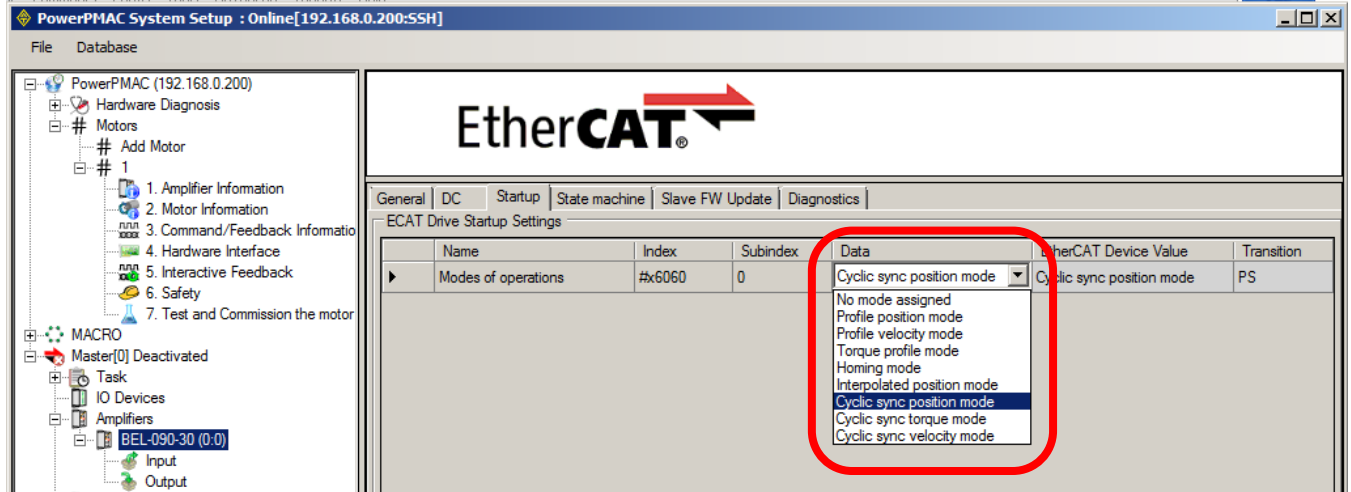

2-Axis Drives

Set up DC the same as the previous for Axis-A. For Axis-B leave the reference-clock item unchecked. On the **Startup** tab, click the box to **Add New from Dictionary object** to set up the startup Mode of operation for Axis B ->

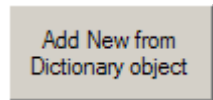

The Axis A Mode of Operation for CSP is #x6060. Axis B will be that + #x0800, or #x6860. Click to highlight that row, and press the **Add** button:

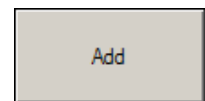
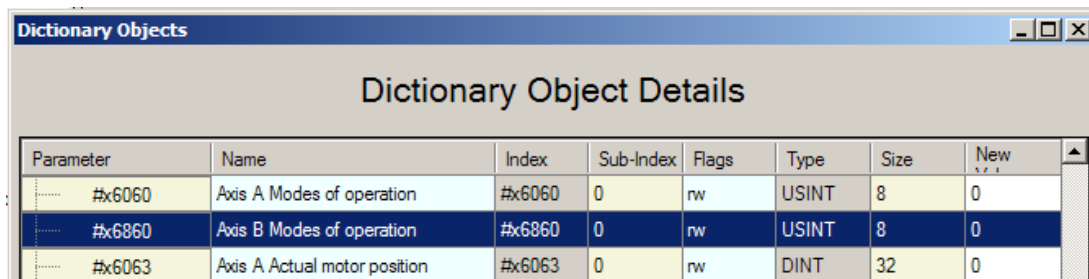

Click in the Data box in the #x6860 row and enter "8", the number of the CSP mode:

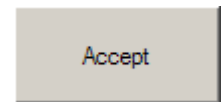
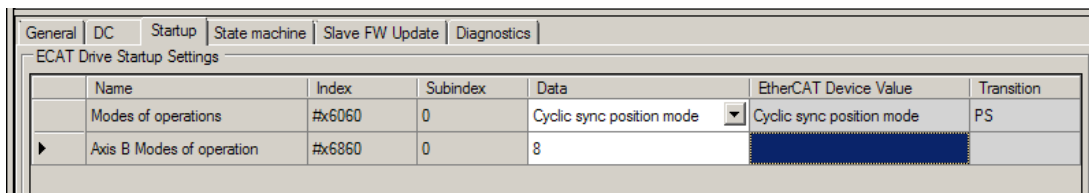

And press **[Accept]** to complete the Startup tab:

Note: In future versions of the IDE, the Axis B Mode of Operation will be set automatically based on the settings in the ESI file.

Input PDO Configuration: 1-Axis

Click on the **Input** item of the drive to show the TxPdo. Note that a PMAC input is a device output. This means that the drive is transmitting data to the PMAC and that the data will be in a drive TxPDO (Transmit PDO). The PDO List shows all of the TxPDO, and **#x1b00** is the ESI file default PDO. This is also assigned to Sync Manager (SM) 3 and contains all of the position, velocity, and torque data as well as the Status Word. After selecting **#x1b00**, click on **[Load PDOs to PMAC]**. This will update the PDO Contents as shown below:

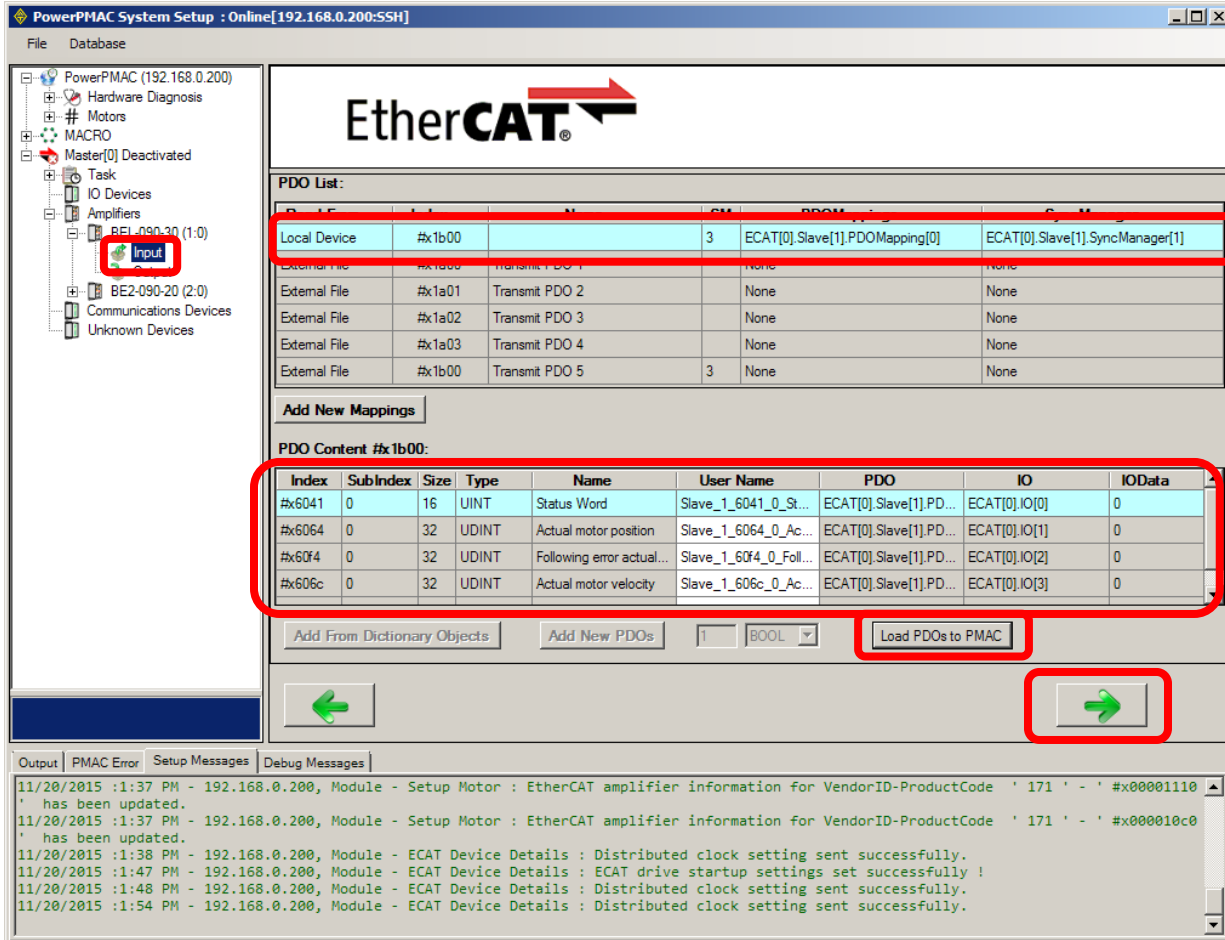

Note: after loading the PDO to the PMAC, the columns PDO, I/O, and IOData all are updated and show data. Click the [->] at the bottom of the screen to go to the next settings.

Input PDO Configuration: 2-Axis

Begin with the selection of #x1b00 as in the 1-axis setup, and clicking **Load PDOs to PMAC**.

The screenshot shows the 'PowerPMAC System Setup' interface. On the left, a tree view shows the configuration for 'BEL-090-30 (2:0)' with 'Input' selected. The main area displays the 'EtherCAT' logo and configuration tables. The 'PDO List' table is as follows:

Read From	Index	Name	SM	PDOMappings	SyncManager
Local Device	#x1b00		3	ECAT[0].Slave[0].PDOMapping[0]	ECAT[0].Slave[0].SyncManager[1]
Local Device	#x1b00		0	None	None
External File	#x1a00	Transmit PDO 1		None	None
External File	#x1a01	Transmit PDO 2		None	None
External File	#x1a02	Transmit PDO 3		None	None
External File	#x1a03	Transmit PDO 4		None	None

Below the 'PDO List' is the 'PDO Content #x1b00:' table:

Index	SubIndex	Size	Type	Name	User Name	PDO	IO	IOData
#x6041	0	16	UINT	Status Word	Slave_0_6041_0_St...	ECAT[0].Slave[0].PD...	ECAT[0].IO[13]	0
#x6064	0	32	UDINT	Actual motor position	Slave_0_6064_0_Ac...	ECAT[0].Slave[0].PD...	ECAT[0].IO[14]	0
#x60f4	0	32	UDINT	Following error actual...	Slave_0_60f4_0_Foll...	ECAT[0].Slave[0].PD...	ECAT[0].IO[15]	0
#x606c	0	32	UDINT	Actual motor velocity	Slave_0_606c_0_Ac...	ECAT[0].Slave[0].PD...	ECAT[0].IO[16]	0

At the bottom right, there is a 'Load PDOs to PMAC' button.

Then, highlight the row with #x1b40, and click **Load PDOs to PMAC**

The screenshot shows the 'PowerPMAC System Setup' interface. On the left, the tree view shows 'Input' selected. The main area displays the 'EtherCAT' logo and configuration tables. The 'PDO List' table is as follows:

Read From	Index	Name	SM	PDOMappings	SyncManager
Local Device	#x1b00		0	ECAT[0].Slave[0].PDOMapping[0]	ECAT[0].Slave[0].SyncManager[1]
Local Device	#x1b40	Input	3	ECAT[0].Slave[0].PDOMapping[2]	None
Local Device	#x1b40		0	None	None
External File	#x1a01	Transmit PDO 2		None	None
External File	#x1a02	Transmit PDO 3		None	None
External File	#x1a03	Transmit PDO 4		None	None

Below the 'PDO List' is the 'PDO Content #x1b40:' table:

Index	SubIndex	Size	Type	Name	User Name	PDO	IO	IOData
#x6841	0	16	UINT			ECAT[0].Slave[0].PD...	ECAT[0].IO[23]	0
#x6864	0	32	UDINT			ECAT[0].Slave[0].PD...	ECAT[0].IO[24]	0
#x68f4	0	32	UDINT			ECAT[0].Slave[0].PD...	ECAT[0].IO[25]	0
#x686c	0	32	UDINT			ECAT[0].Slave[0].PD...	ECAT[0].IO[26]	0

At the bottom right, there is a 'Load PDOs to PMAC' button.

Output PDO Configuration: 1-Axis

Click on **Output** below the device to show the PDO that the PMAC will send to the device. **#x1700** is the drive RxPdo containing the Control Word, and target position, velocity offset (velocity feedforward), and torque offset (acceleration feedforward). Click **[Load PDOs to PMAC]** and the PDO Contents will update. Click the **[->]** at the bottom of the screen to go to the next settings.

The screenshot shows the 'PowerPMAC System Setup' application. The left sidebar shows a tree view with 'Output' selected under the 'BEL-090-30 (1.0)' device. The main area displays the EtherCAT logo and configuration options. Two tables are visible:

PDO List:

Local From	Index	Name	DM	PDOMappings	SyncManager
Local Device	#x1700		2	ECAT[0].Slave[1].PDOMapping[1]	ECAT[0].Slave[1].SyncManager[0]
External File	#x1600	Receive PDO 1		None	None
External File	#x1601	Receive PDO 2		None	None
External File	#x1602	Receive PDO 3		None	None
External File	#x1603	Receive PDO 4		None	None
External File	#x1700	Receive PDO 5	2	None	None

PDO Content #x1700:

Index	SubIndex	Size	Type	Name	User Name	PDO	IO	IOData
#x6040	0	16	UINT	Control Word	Slave_1_6040_0_Co...	ECAT[0].Slave[1].PD...	ECAT[0].IO[5]	0
#x607a	0	32	UDINT	Target Position	Slave_1_607a_0_Tar...	ECAT[0].Slave[1].PD...	ECAT[0].IO[6]	0
#x60b1	0	32	UDINT	Velocity offset	Slave_1_60b1_0_Vel...	ECAT[0].Slave[1].PD...	ECAT[0].IO[7]	0
#x60b2	0	16	UINT	Torque offset	Slave_1_60b2_0_Tor...	ECAT[0].Slave[1].PD...	ECAT[0].IO[8]	0

At the bottom, there are buttons for 'Add From Dictionary Objects', 'Add New PDOs', a dropdown menu set to '1' with 'BOOL' selected, and a 'Load PDOs to PMAC' button. Below these are two green arrow buttons for navigation.

The message log at the bottom shows the following output:

```

11/20/2015 1:37 PM - 192.168.0.200, Module - Setup Motor : EtherCAT amplifier information for VendorID-ProductCode ' 171 ' - ' #x00001110 ' has been updated.
11/20/2015 1:37 PM - 192.168.0.200, Module - Setup Motor : EtherCAT amplifier information for VendorID-ProductCode ' 171 ' - ' #x000010c0 ' has been updated.
11/20/2015 1:38 PM - 192.168.0.200, Module - ECAT Device Details : Distributed clock setting sent successfully.
11/20/2015 1:47 PM - 192.168.0.200, Module - ECAT Device Details : ECAT drive startup settings set successfully !
11/20/2015 1:48 PM - 192.168.0.200, Module - ECAT Device Details : Distributed clock setting sent successfully.
11/20/2015 1:54 PM - 192.168.0.200, Module - ECAT Device Details : Distributed clock setting sent successfully.
    
```

Output PDO Configuration: 2-Axis

Click on **Output** below the device to show the PDO that the PMAC will send to the device. #x1700 is the drive RxPdo containing the Control Word, and target position, velocity offset (velocity feedforward), and torque offset (acceleration feedforward) for Axis-A. Click [**Load PDOs to PMAC**] and the PDO Contents will update. Click the [**->**] at the bottom of the screen to go to the next settings.

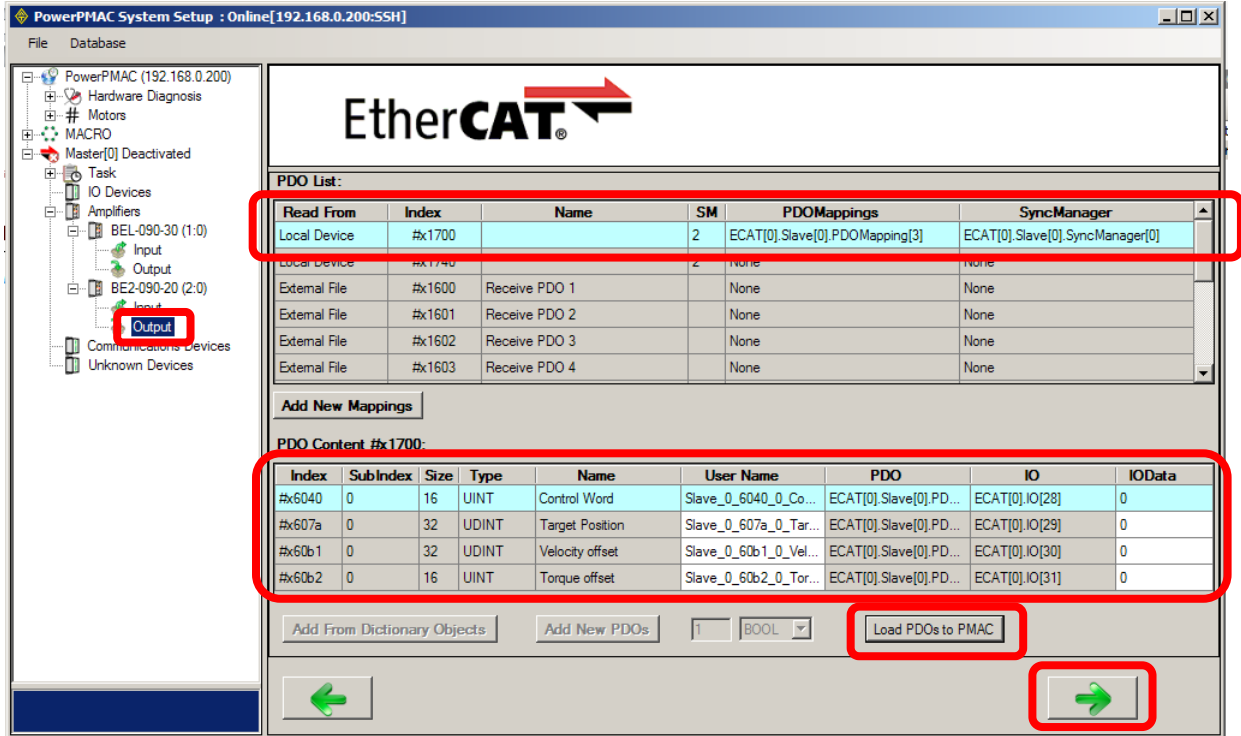

Next, highlight the row with #x1740, click [**Load PDOs to PMAC**] and the PDO Contents will update the PDOs for Axis-B. Click the [**->**] at the bottom of the screen to go to the next settings.

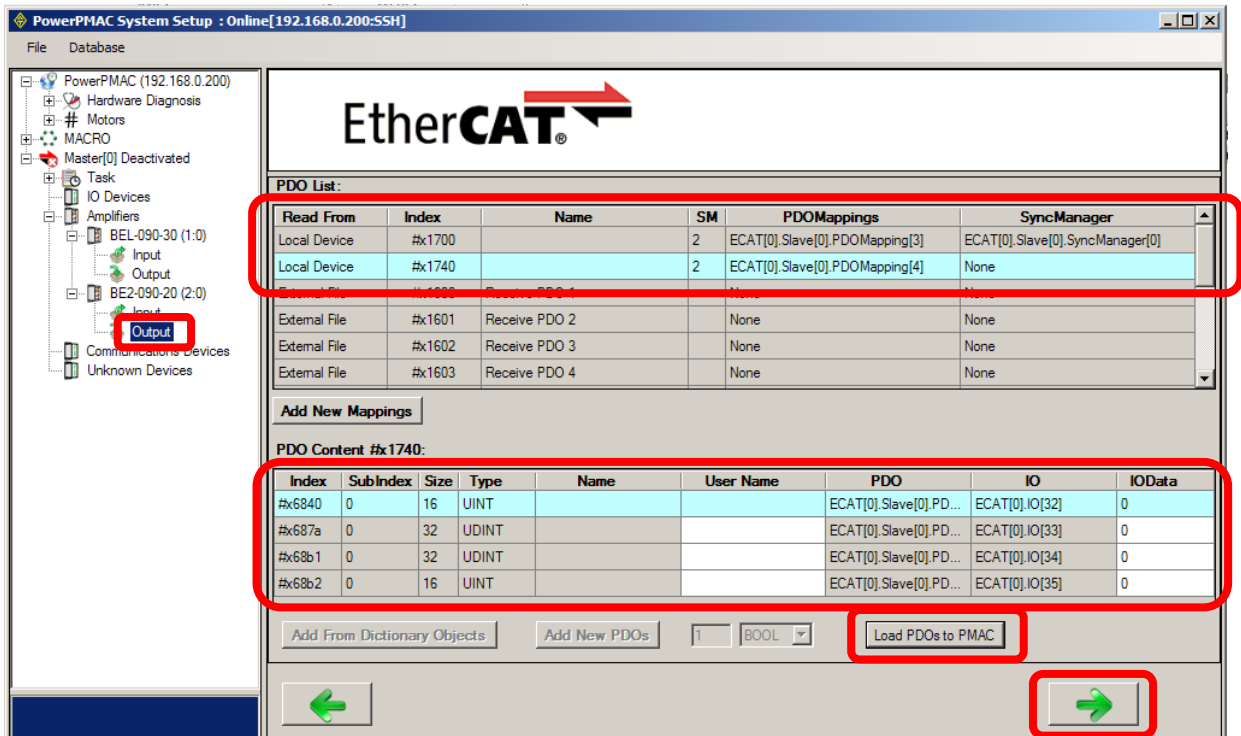

Motor Configuration

Note that “Motor” has two meanings in the PMAC. What is commonly called an *Axis* in other EtherCAT masters is called a **Motor** in Delta-Tau controllers. And, a Delta-Tau **Motor** comprises the servo drive, a physical motor, and any feedback devices connected to the motor and/or the load.

The screenshot shows the 'PowerPMAC System Setup' interface. The tree view is expanded to show the configuration for 'Motor #1'. The following elements are highlighted with red boxes and arrows, with corresponding text boxes:

- Motors**: A red box highlights the 'Motors' folder. A text box points to it: "Motors" here are motion axes and refers to the servo-drives AND the actual motors attached to them.
- # 1**: A red box highlights the 'Motor #1' folder. A text box points to it: This number is **Motor #1**.
- 1. Amplifier Information**: A red box highlights this sub-item. A text box points to it: This is a Copley BEL servo drive.
- 2. Motor Information**: A red box highlights this sub-item. A text box points to it: This is an actual motor.
- 3. Command/Feedback Information**: A red box highlights this sub-item. A text box points to it: Position Feedback encoders on the actual motor.
- BEL-090-30 (0:0)**: A red box highlights this device under the 'Amplifiers' folder. A text box points to it: This device is "1.Amplifier Information" under **Motor #1** above.

Add a New Motor

Click on **Motors** to Add a New Motor. Start with "1". In this example, **Motors #1** will be linked to the BEL amplifier.

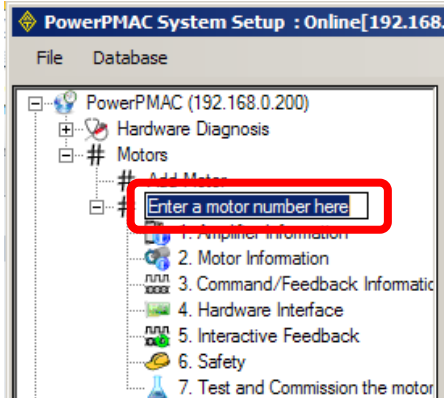

Amplifier Information

Click on the **Amplifier Information** item under **Motor #1**. This shows the information from the device under the **Amplifiers** section of the **Master[0]** folder tree.

Click on **Manufacturer** and select **Copley Controls (EtherCAT:171)**. Next, click on Part Number, and find the one that brings up the Product Description that matches the model in **Master[0] Deactivated > Amplifiers**:

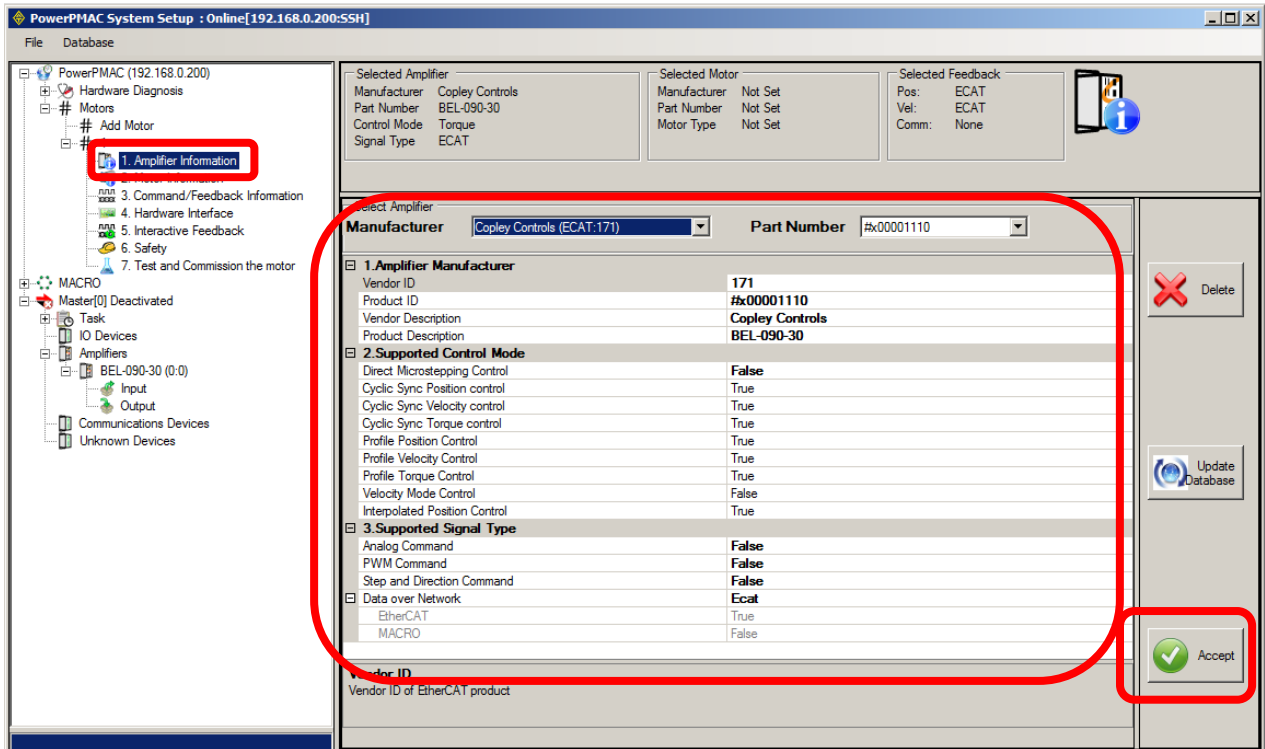
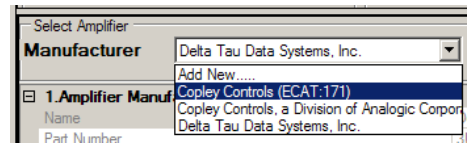

After the drive has been selected, the settings in **Supported Control Mode** and **Supported Signal Type** should appear as above.

Click **[Accept]** to continue.

Motor Information

Because the actual motor has already been specified and set up in the BEL configuration, it is not necessary to add information on the motor in this step. Click **[>]** to continue.

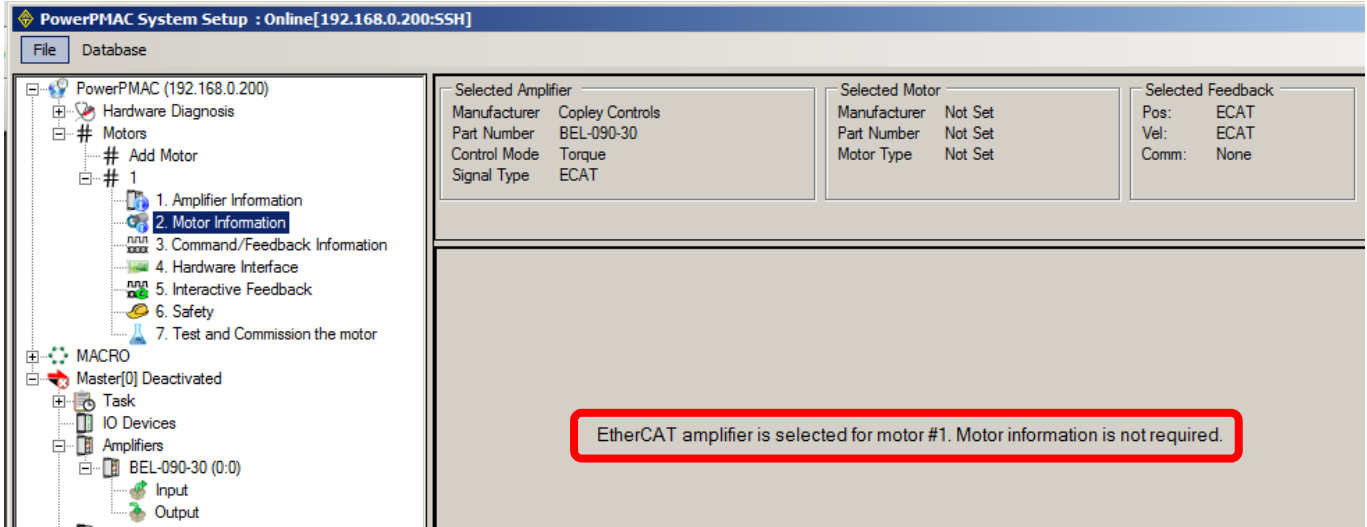

Command/Feedback Information

Under the **Amplifier Control/Signal** item, there is a pull-down listing. Select **Cyclic Position** which works with the CSP Mode of Operation that was set up in the device configuration. In this example, the only feedback is **Primary Feedback** from the motor encoder which sends the position data via EtherCAT (**ECAT**) to the PMAC. If there is a secondary feedback encoder on the load, that would be entered under the **Dual Feedback** item.

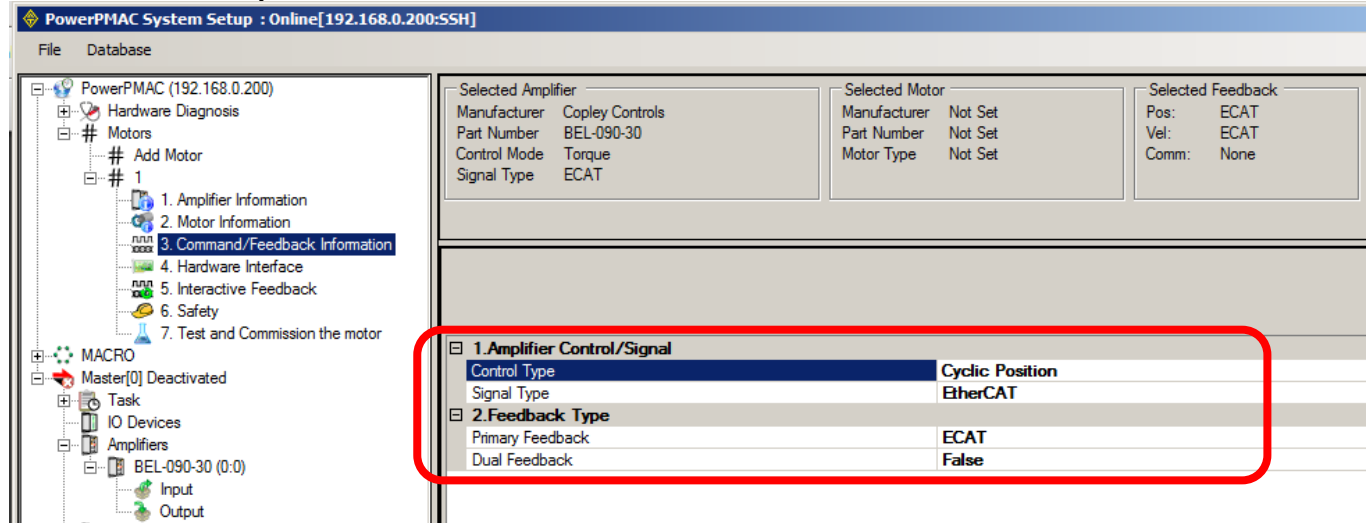

Click **[Accept]** to continue.

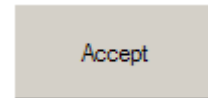

Hardware Interface: 1-Axis Drives

Amplifier Control/Signal Make these selections from the pull-downs for each item.

1. Amplifier Control/Signal	
Control Type	Cyclic Position
Signal Type	EtherCAT
2. Feedback Type	
Primary Feedback	ECAT
Dual Feedback	False

Amplifier Interface

To configure these items, click on *Please select etherCAT address*

2. Amplifier Interface	
Command Signal Channel	Invalid EtherCAT address. Please select etherCAT address.
Amplifier Enable Signal Output Channel	Invalid EtherCAT address. Please select etherCAT address.
Amplifier Fault Signal Input Channel	
3. Feedback Interface	
Primary Feedback Channel	

Scroll down and select #x607a for the **Command Signal Channel** of amplifier that was selected for **Motor #1**:
Select #x6040 for the **Amplifier Enable Signal Output Channel**
Select #x6041 for **Amplifier Fault Signal Input Channel**
Select #x6064 for **Primary Feedback Channel**

1. Amplifier Control/Signal	
Control Type	Cyclic Position
Signal Type	EtherCAT
2. Amplifier Interface	
Command Signal Channel	BEL-090-30 (1:0) (#x607a) - (Slave_1_607a_0_TargetPosition)
Amplifier Enable Signal Output Channel	BEL-090-30 (1:0) (#x6040) - (Slave_1_6040_0_ControlWord)
Amplifier Fault Signal Input Channel	BEL-090-30 (1:0) (#x6041) - (Slave_1_6041_0_StatusWord)
3. Feedback Interface	
Primary Feedback Channel	BEL-090-30 (1:0) (#x6064) - (Slave_1_6064_0_Actualmotorpositi)

This is how it looks after selections are completed:

PowerPMAC System Setup : Online[192.168.0.200-SSH]

File Database

PowerPMAC (192.168.0.200)

- Hardware Diagnosis
 - Motors
 - # Add Motor
 - # 1
 - 1. Amplifier Information
 - 2. Motor Information
 - 3. Command/Feedback Information
 - 4. Hardware Interface
 - 5. Interactive Feedback
 - 6. Safety
 - 7. Test and Commission the motor
 - # 2
 - 1. Amplifier Information
 - 2. Motor Information
 - 3. Command/Feedback Information

Selected Amplifier
Manufacturer: Copley Controls
Part Number: BEL-090-30
Control Mode: Position
Signal Type: ECAT

Selected Motor
Manufacturer: Not Set
Part Number: Not Set
Motor Type: Not Set

Selected Feedback
Pos: ECAT
Vel: ECAT
Comm: None

1. Amplifier Control/Signal	
Control Type	Cyclic Position
Signal Type	EtherCAT
2. Amplifier Interface	
Command Signal Channel	BEL-090-30 (1:0) (#x607a) - (Slave_1_607a_0_TargetPosition)
Amplifier Enable Signal Output Channel	BEL-090-30 (1:0) (#x6040) - (Slave_1_6040_0_ControlWord)
Amplifier Fault Signal Input Channel	BEL-090-30 (1:0) (#x6041) - (Slave_1_6041_0_StatusWord)
3. Feedback Interface	
Primary Feedback Channel	BEL-090-30 (1:0) (#x6064) - (Slave_1_6064_0_Actualmotorpositi)

Click **[Accept]** to continue.

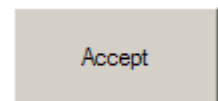

Hardware Interface: 2-Axis Drives, Axis A

Click on **Motors** to Add a New Motor. In this example, **Motor #2** will be linked to the BE2 amplifier, Axis A: **Important! Each axis of a 2-axis drive will be configured as a separate Motor # !**

Amplifier Information Select BE2 drive
Click **[Accept]** to continue.

Select Amplifier		Accept
Manufacturer	Copley Controls (ECAT:171)	Part Number #x000010C0
1. Amplifier Manufacturer		
Vendor ID	171	
Product ID	#x000010C0	
Vendor Description	Copley Controls	
Product Description	BE2-090-20	
2. Supported Control Mode		

Command/Feedback Information:

Amplifier Control/Signal and **Feedback Type** Should appear as below.
Click **[Accept]** to continue.

Accept	
1. Amplifier Control/Signal	
Control Type	Cyclic Position
Signal Type	EtherCAT
2. Feedback Type	
Primary Feedback	ECAT
Dual Feedback	False

Hardware Interface

To configure these items, click on **Please select etherCAT address**

2. Amplifier Interface	
Command Signal Channel	Invalid EtherCAT address. Please select etherCAT address.
Amplifier Enable Signal Output Channel	Invalid EtherCAT address. Please select etherCAT address.
Amplifier Fault Signal Input Channel	
3. Feedback Interface	
Primary Feedback Channel	

Scroll down and select #x607a for the **Command Signal Channel** of amplifier that was selected for **Motor #1**:
Select #x6040 for the **Amplifier Enable Signal Output Channel**
Select #x6041 for **Amplifier Fault Signal Input Channel**
Select #x6064 for **Primary Feedback Channel**
Click **[Accept]** to continue.

Accept	
1. Amplifier Control/Signal	
Control Type	Cyclic Position
Signal Type	EtherCAT
2. Amplifier Interface	
Command Signal Channel	BE2-090-20 (2:0) (#x607a) - (Slave_0_607a_0_TargetPosition)
Amplifier Enable Signal Output Channel	BE2-090-20 (2:0) (#x6040) - (Slave_0_6040_0_ControlWord)
Amplifier Fault Signal Input Channel	BE2-090-20 (2:0) (#x6041) - (Slave_0_6041_0_StatusWord)
3. Feedback Interface	
Primary Feedback Channel	BE2-090-20 (2:0) (#x6064) - (Slave_0_6064_0_Actualmotorpositi)

Safety

The items in this section can be configured in the Copley servo drive. These include:

- I2T Current Limiting
- Position Following Error limits
- Software pos/neg position limits

Hardware Interface: 2-Axis Drives, Axis B

Click on **Motors** to Add a New Motor. In this example, **Motor #3** will be linked to the BE2 amplifier, Axis B: **Important! Each axis of a 2-axis drive will be configured as a separate Motor # !**

Amplifier Information Select BE2 drive
Click **[Accept]** to continue.

Select Amplifier		Accept
Manufacturer	Copley Controls (ECAT:171)	Part Number #x000010C0
1. Amplifier Manufacturer		
Vendor ID	171	
Product ID	#x000010C0	
Vendor Description	Copley Controls	
Product Description	BE2-090-20	
2. Supported Control Mode		

Command/Feedback Information:

Amplifier Control/Signal and **Feedback Type** Should appear as below.
Click **[Accept]** to continue.

1. Amplifier Control/Signal		Accept
Control Type	Cyclic Position	
Signal Type	EtherCAT	
2. Feedback Type		
Primary Feedback	ECAT	
Dual Feedback	False	

Hardware Interface

To configure these items, click on **Please select etherCAT address**
Important, object numbers for Axis B will be \$xn8nn !

2. Amplifier Interface	
Command Signal Channel	Invalid EtherCAT address. Please select etherCAT address.
Amplifier Enable Signal Output Channel	Invalid EtherCAT address. Please select etherCAT address.
Amplifier Fault Signal Input Channel	
3. Feedback Interface	
Primary Feedback Channel	

Scroll down and select #x687a for the **Command Signal Channel** of amplifier that was selected for Motor #1:
Select #x6840 for the **Amplifier Enable Signal Output Channel**
Select #x6841 for **Amplifier Fault Signal Input Channel**
Select #x6864 for **Primary Feedback Channel**
Click **[Accept]** to continue.

2. Amplifier Interface		Accept
Command Signal Channel	BE2-090-20 (2:0) (#x687a)	
Amplifier Enable Signal Output Channel	BE2-090-20 (2:0) (#x6840)	
Amplifier Fault Signal Input Channel	BE2-090-20 (2:0) (#x6841)	
3. Feedback Interface		
Primary Feedback Channel	BE2-090-20 (2:0) (#x6864)	

Safety

The items in this section can be configured in the Copley servo drive. These include:

- I2T Current Limiting
- Position Following Error limits
- Software pos/neg position limits

Create Set-Up Files and Save the EtherCAT Project

Export EtherCAT Variables

From **System Setup**, click this to export EtherCAT variables. This will create three files.

- filename.h
- EcatActivate0.cfg
- filename.pmh

Filename is the user's name for the file.

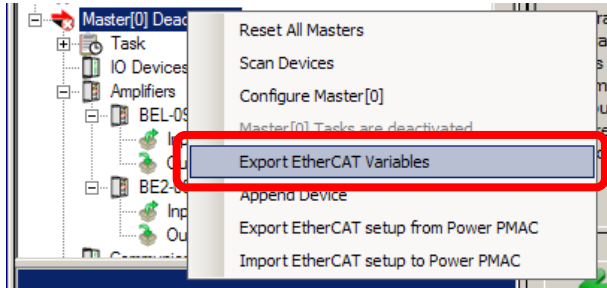

The *.h, *.cfg, and *.pmh files were created by **Export EtherCAT Variables**

This is the confirmation of the files created by clicking Export EtherCAT Variables (file names may vary but they always go to these folders.

Power PMAC Project File Organization

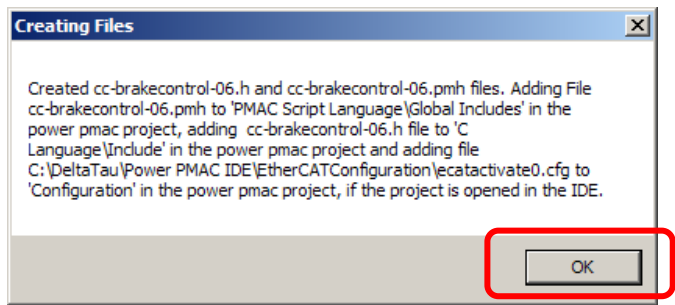
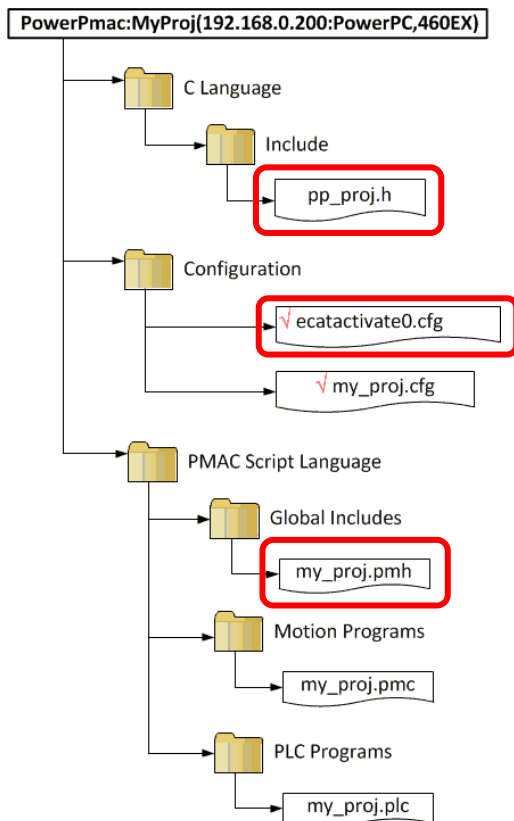

Click **Yes to All** when this screen opens

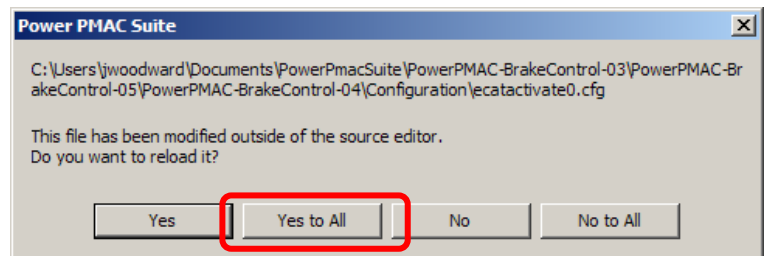

The files created by this operation are saved only to the PC hard drive!

Generate and Save a Configuration File

In the Solution Explorer, right-click on the Configuration folder and select Generate Configuration File. This file contains all of the settings that were made in System Setup.

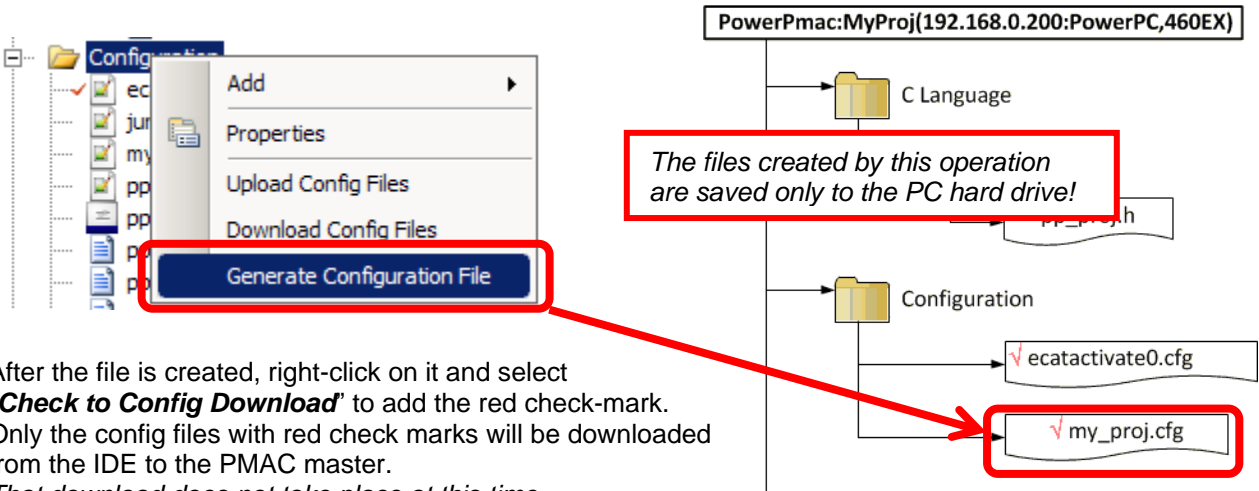

After the file is created, right-click on it and select **“Check to Config Download”** to add the red check-mark. Only the config files with red check marks will be downloaded from the IDE to the PMAC master. That download does not take place at this time.

Save All settings to the computer’s hard drive.

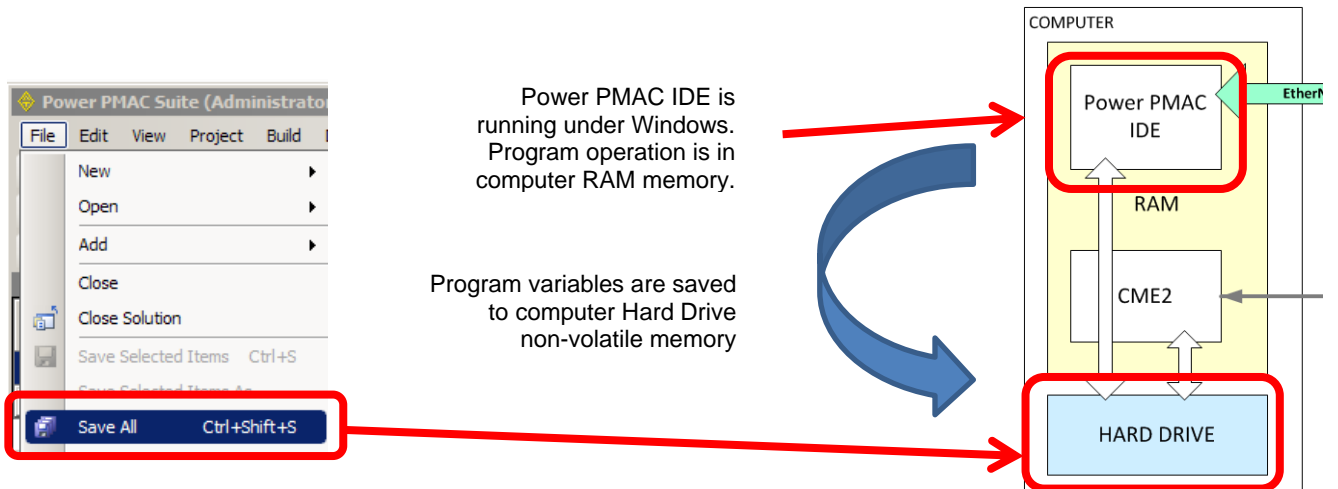

PMAC System Structure

A PMAC system has three components, each of which has volatile (RAM) and non-volatile (Flash) storage. When the word “save” is used in the following discussions it means that data is copied from RAM memory to Flash memory. But, as the diagram shows, it is very important to understand clearly just where the from > operation is taking place.

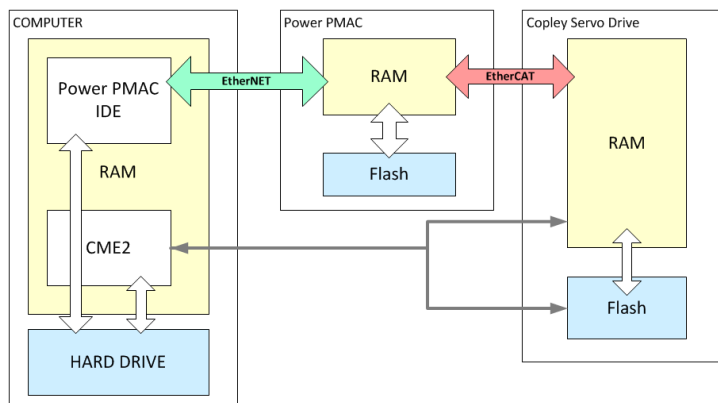

Generate and Save the EcatActivate0.cfg File

This file is run every time that the EtherCAT Master[0] is activated.
 Activation occurs when this is entered in the Terminal Window **EtherCAT[0].Enable=1**

After the file is created, right-click on it and select “Check to Config Download” to add the red check-mark. Only the config files with red check marks will be downloaded from the IDE to the PMAC master.

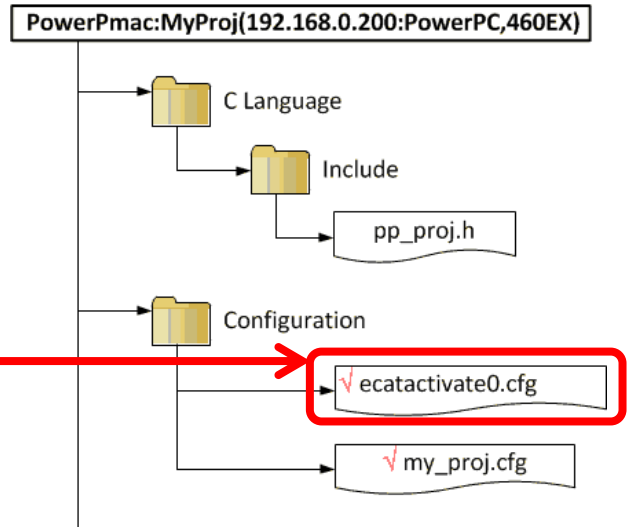
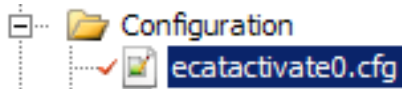

Here is the contents of the file.
 Note the “10” is actually a lower-case L0 which is a “Local L-variable”.

```

ecatactivate0.cfg  cc-brakecontrol-06.h  cc-brakecontrol-06.pmh
L0 = ecatsdo(0,0,$6060,0,8,0)
L0 = ecatsdo(0,1,$6060,0,8,0)
L0 = ecatsdo(0,1,$6860,0,8,0)
    
```

These configure EtherCAT SDOs that set the Mode of Operation of the drives and axes. The first digit 0 means that this is a write-SDO, sending data to the drive. Second is the slave index where 0 is the first slave in the example, the 1-axis BEL. When this is a 1, it is the second slave, the 2-axis BE2. Note that two SDOs are written to the BE2, setting the Mode of Operation for Axis-A and Axis-B. Index \$6060 is the basic one for setting Mode of Operation and is the same for single-axis drives and the Axis-A of two-axis drives. Index \$6860 is for Axis-B and has the 0x0800 offset from the \$6060 that is used for Axis-B of 2-axis drives.

Download the Config Files

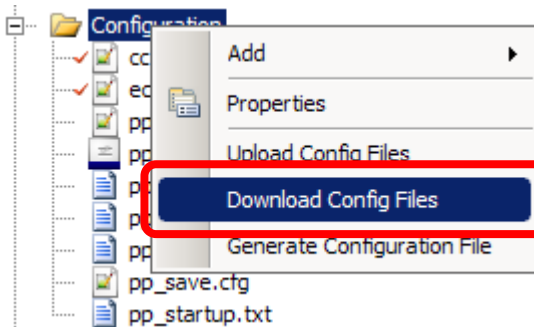

The files created by this operation are saved only to the PC hard drive!

Save the Configuration

Reset the PMAC

Command Entries and Response

The Terminal window is the primary user interface in the PMAC. This is where commands are entered and parameters can be read and written as **On-Line Commands**. These have immediate effect when entered. The frame above the terminal window is a scrolling display of the commands entered and the PMAC responses to those commands.

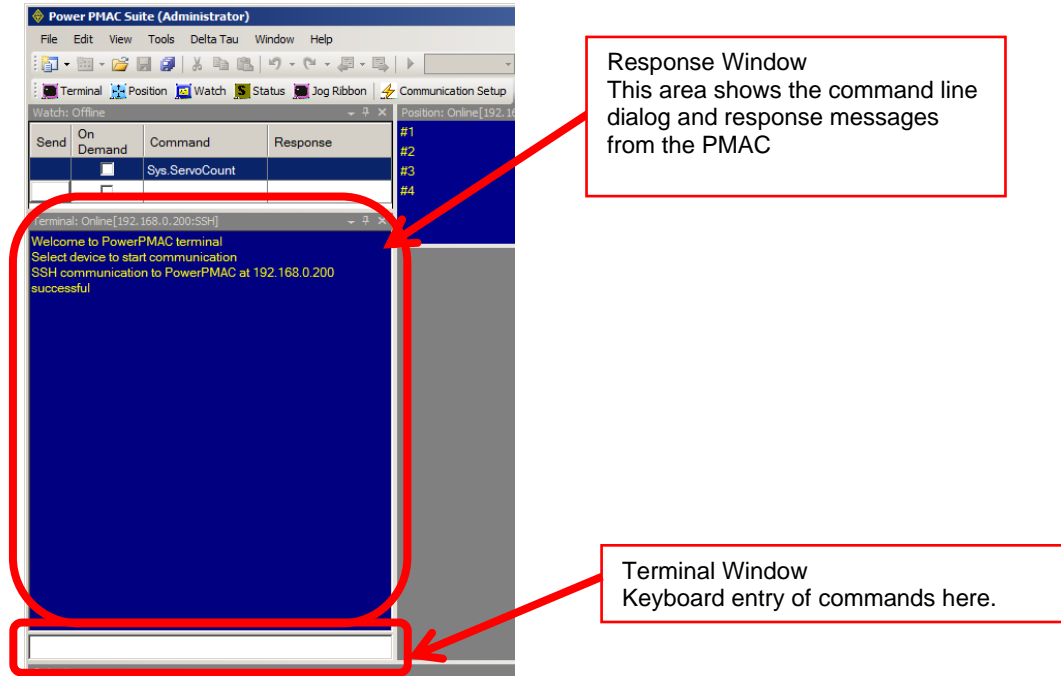

Some typical On-Line Commands

Set the EtherCAT operation to RUN:

ECAT[0].Enable = 1

Enable Motor #1:

#1/

Enable Motors #1,2,3:

#1..3/ or #1,2,3

Jog Motor #1 positive:

#1j+

Jog Motor #1,2,3 positive:

#1..3j+

Disable all Motors:

k

6.4 Acontis EC-Master Windows: Quick Setup w/ SE2

Introduction

This section provides a quick and basic walkthrough of how to use the Acontis EC-Engineer and EC-Master Windows stack to control a Copley Controls SE2 drive operating in UV Command Mode. It will only cover the basics of utilizing the EC-SlaveTestApplication that is included with installation. It will cover loading the ESI file in EC-Engineer, configuring the EtherCAT settings and exporting the ENI file for use in the EC-Master example. In the EC-Master EC-SlaveTestApplication slave settings will be configured and the output process data will be updated to provide UV current commands to the coils.

The EC-Engineer and EC-Master Windows installations come with user manuals. It is highly recommended that the user manuals are read prior to reading this guide. It is recommended to start with the EC-Master Quickstart Guide.

The Acontis software EC-Engineer and EC-Master Windows must be installed prior to this walkthrough.

ESI Files

Download the ESI file from the Copley Controls web-site:

<http://www.copleycontrols.com/Motion/zip/ecatxml.zip>

The ESI files are used by the EC-Engineer software create an ENI file which contains information on all of the slaves on the network.

Start the Acontis EC-Engineer Software

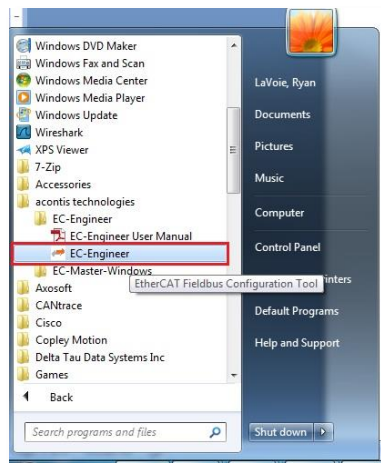

Make sure Configuration Mode is highlighted, then select "Online Configuration".

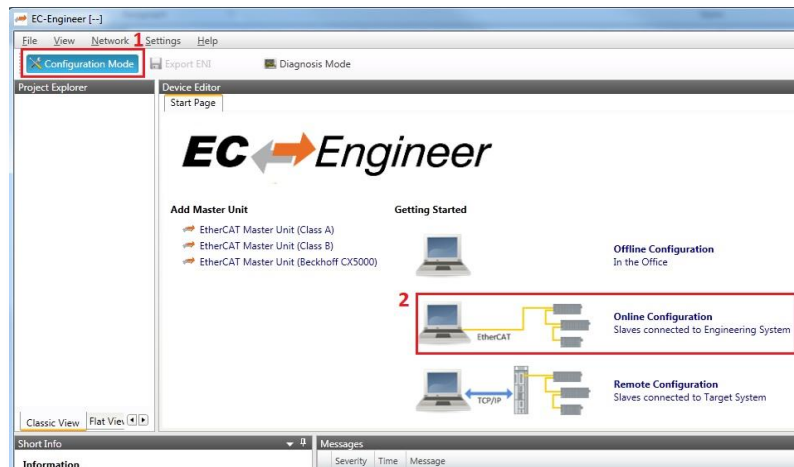

Scan the Network for Devices

Select EtherCAT Master Unit (Class A) and press OK.

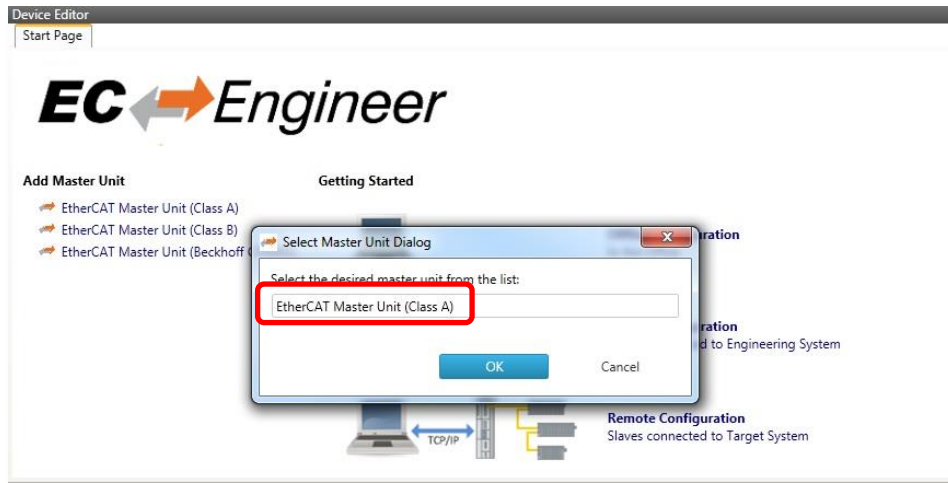

In the Device Editor tab, select the network adapter you wish to use. Adjust the Cycle Time to 4 ms (4000 us) then press Select.

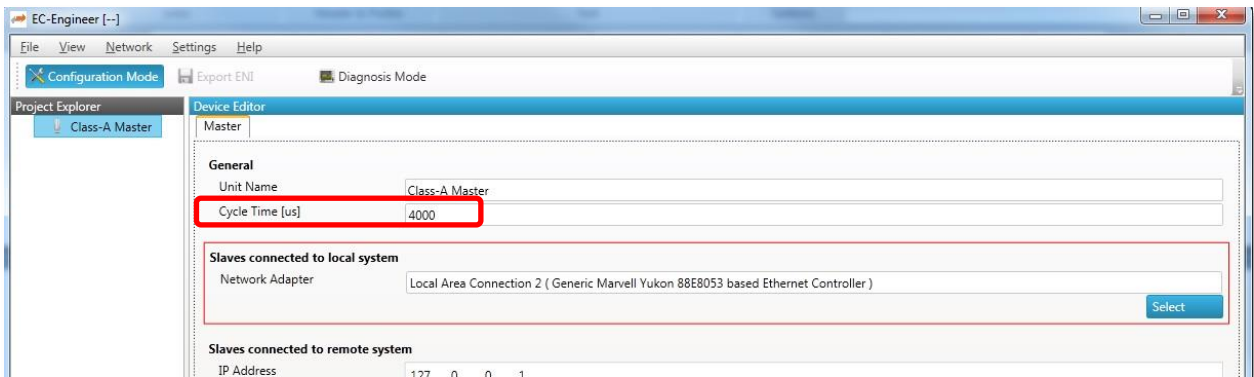

The EC-Engineer will now scan for devices on the network. If the scan and connection was successful you will see the device listed under the Class-A Master in the Project Explorer viewer. The Select button will also have changed to Deselect – allowing for a different network adapter to be chosen if necessary.

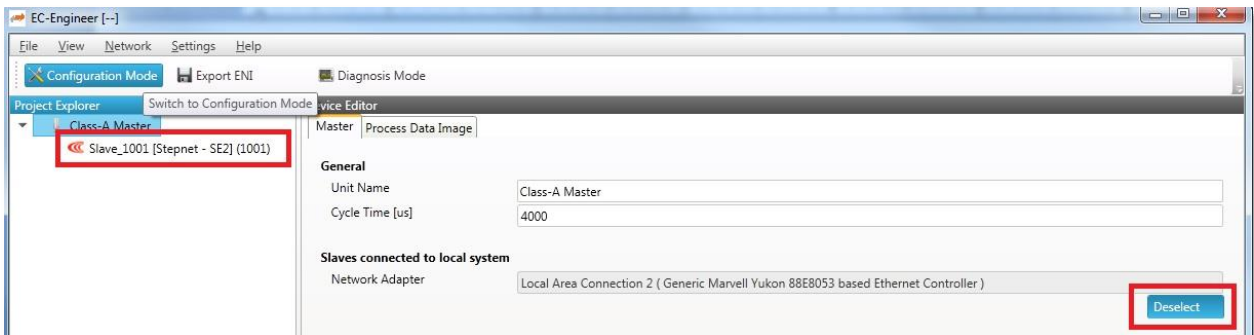

Configure Device PDOs

The SE2 drive is now listed as a slave. If we select this drive in the Project Explorer window, we can begin to look at its process data information as loaded by the ESI file. In this case, we see three PDOs are currently active, one TPDO that contains the Amplifier Event Status register for each axis, as well as the Actual A and B currents for each axis. We also see two RPDOs, one for each axis, which contains the commanded U and V current when running in UV mode.

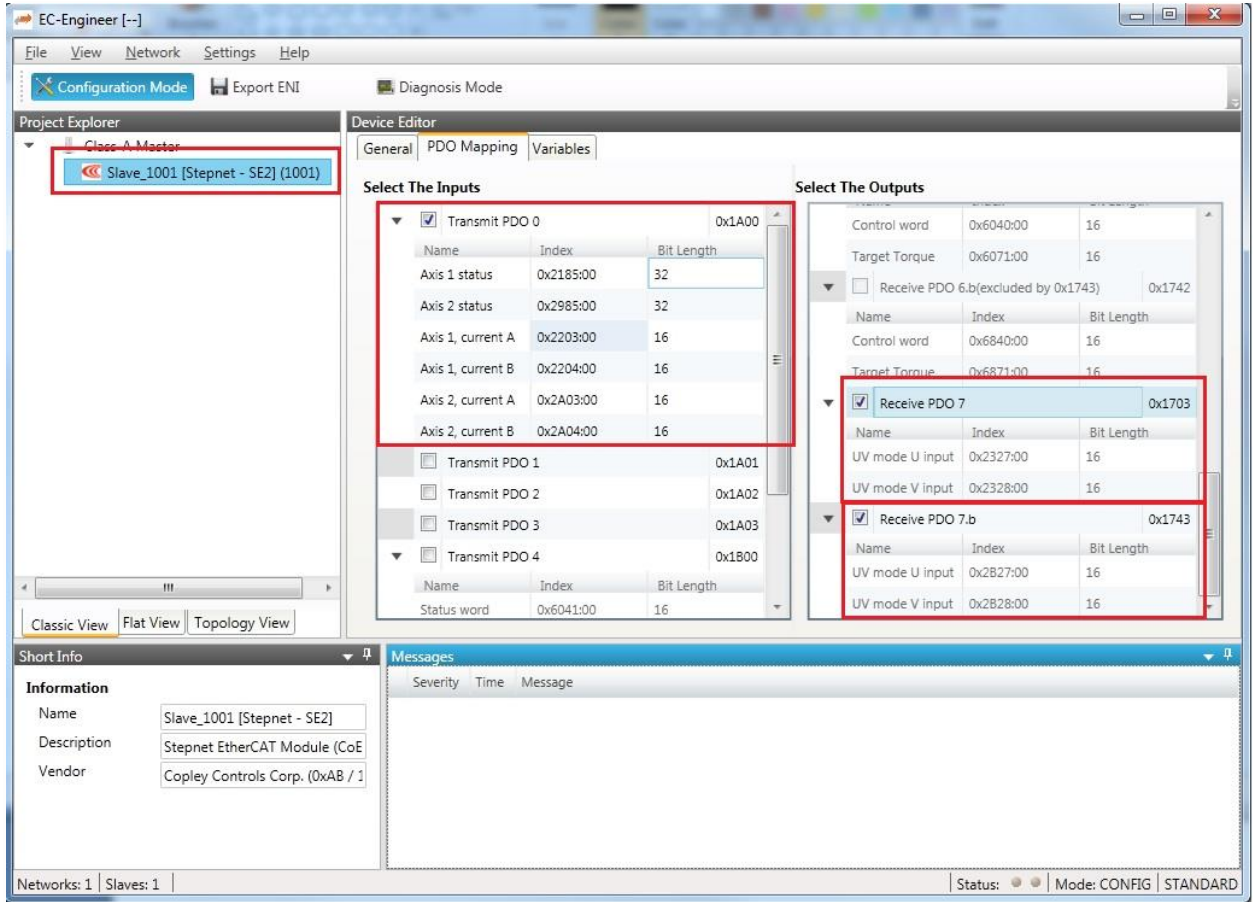

Export the ENI File

Once it is confirmed that the PDO Mapping matches what is expected, the ENI file can be exported for use with the EC-Master Windows software.

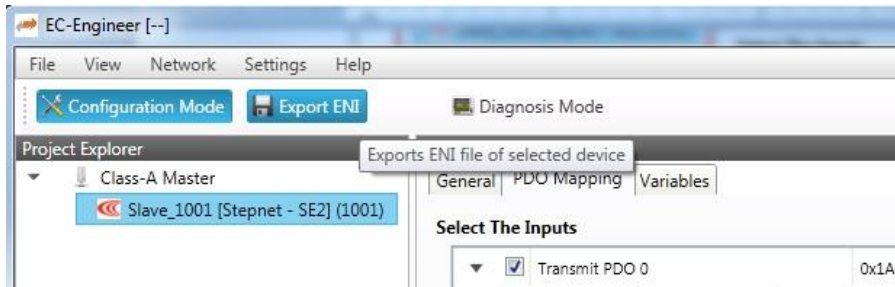

Now the installed EC-SlaveTestApplication example will be used to control the output data of the SE2 unit, and confirm its current values in CME2 using the ASCII command line.

Initialize the Drive on the Network

Navigate to the EC-SlaveTestApplication shortcut in the Start Menu under acontis technologies->EC-Master-Windows.

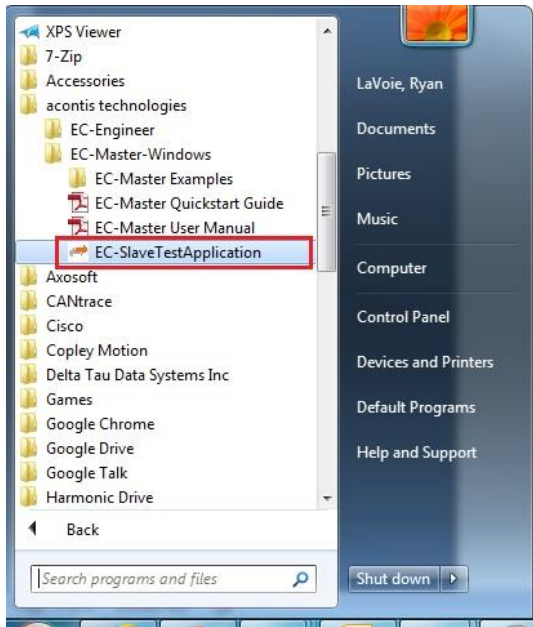

Now select the proper settings for our master application. First select “Local” and make sure the LinkLayer is targeting WinPCAP and the adapter is the same adapter you used when creating the ENI file in EC-Engineer (1). Next point the Acontis EC-Master software to the ENI file created (2).

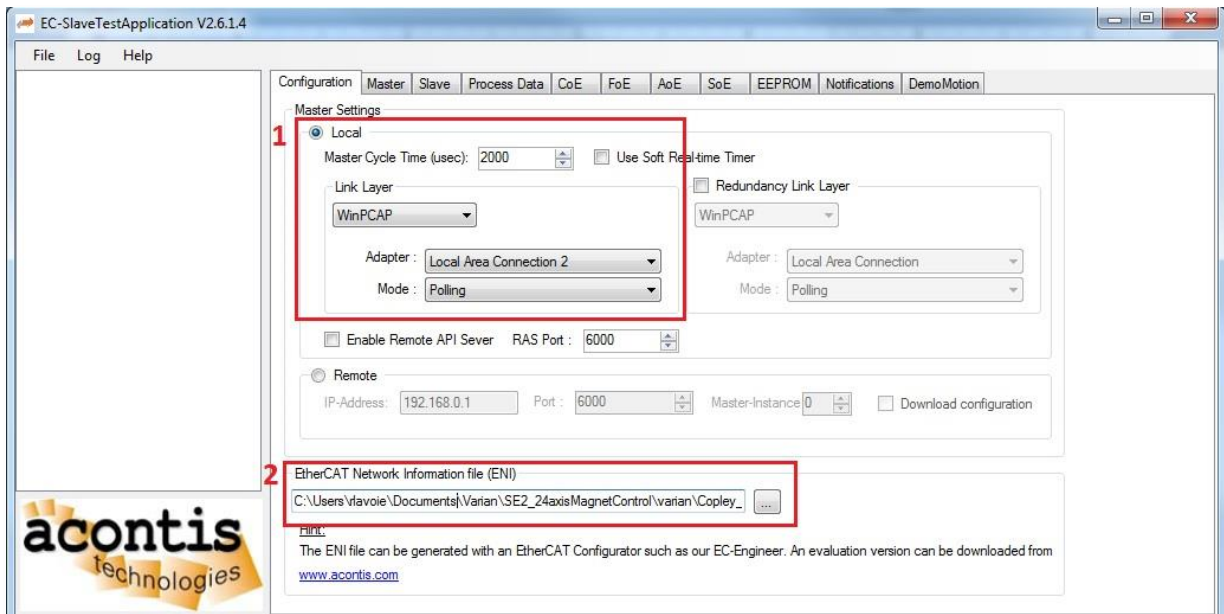

Select the “Master” tab and click the “Initialize” button. This will issue the commands to initialize the EtherCAT network.

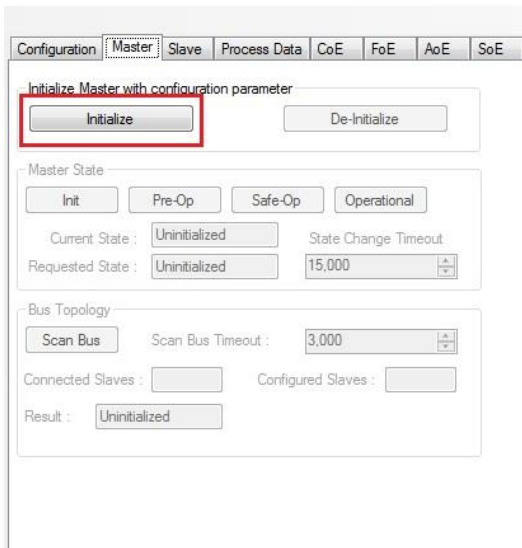

If the initialization was successful, all current slaves on the EtherCAT bus initialize with EC-Master Windows will be listed under the “Master” top level tree label. When the bus is first initialized, the master state will be “UNKOWN” and the slave state will be “INIT”.

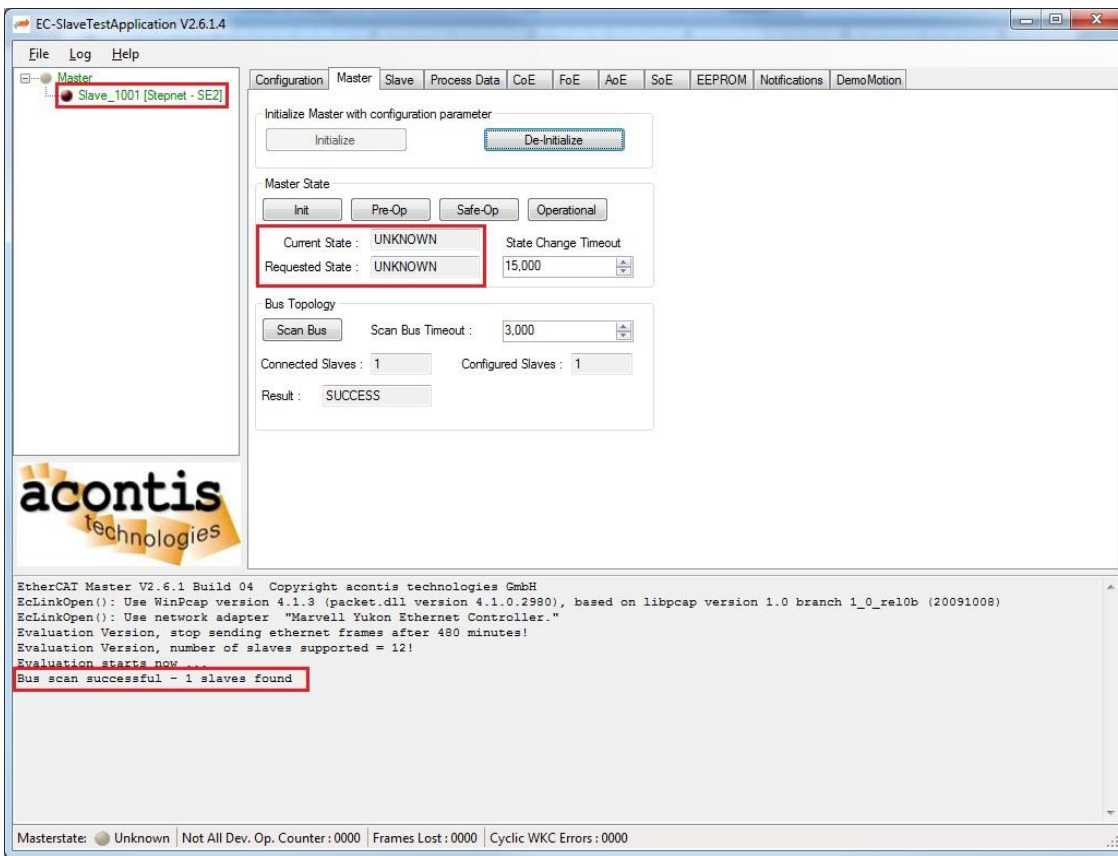

Change the Drive State from Init to Operational

The first step is to move the master and slave into the operational state. Click on the Operational button to change the master state to Operational. This will also issue commands to the slaves and bring them to the operational state as well. When the operational state is requested you will see the “Requested State” indicator change immediately, whereas the “Current State” may take a bit longer. If necessary, adjust the “State Change Timeout” to prevent timeout before state change occurs.

State change sequence: UNKNOWN->INIT->PREOP->SAFEOP->OP

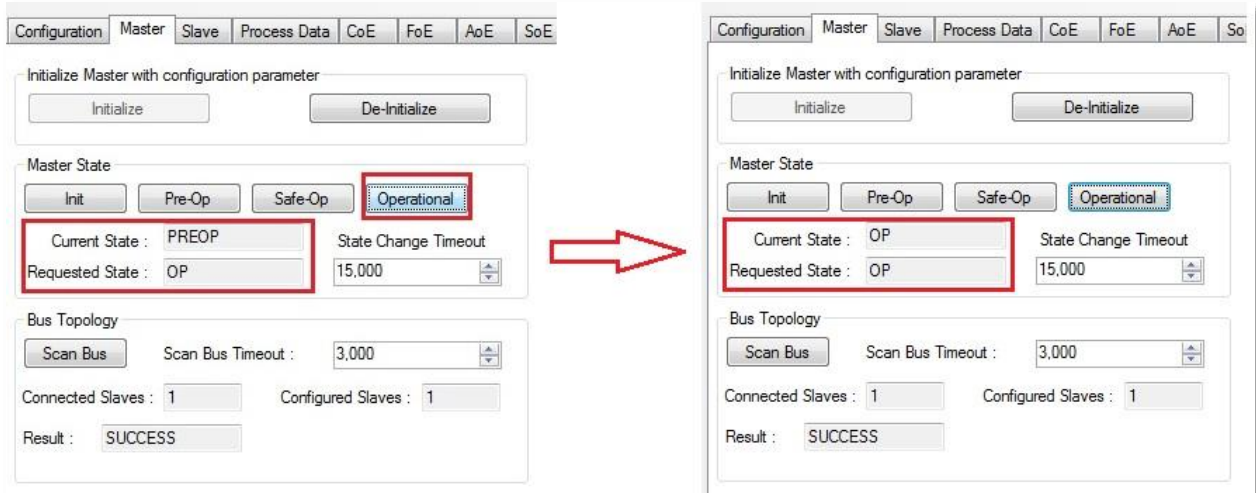

Confirm that the slave has also moved to the Operational state by selecting the “Slave” tab. ****Note:** If no information is displayed when the “Slave” tab is selected, make sure the slave has been selected in the tree under the listed Master.

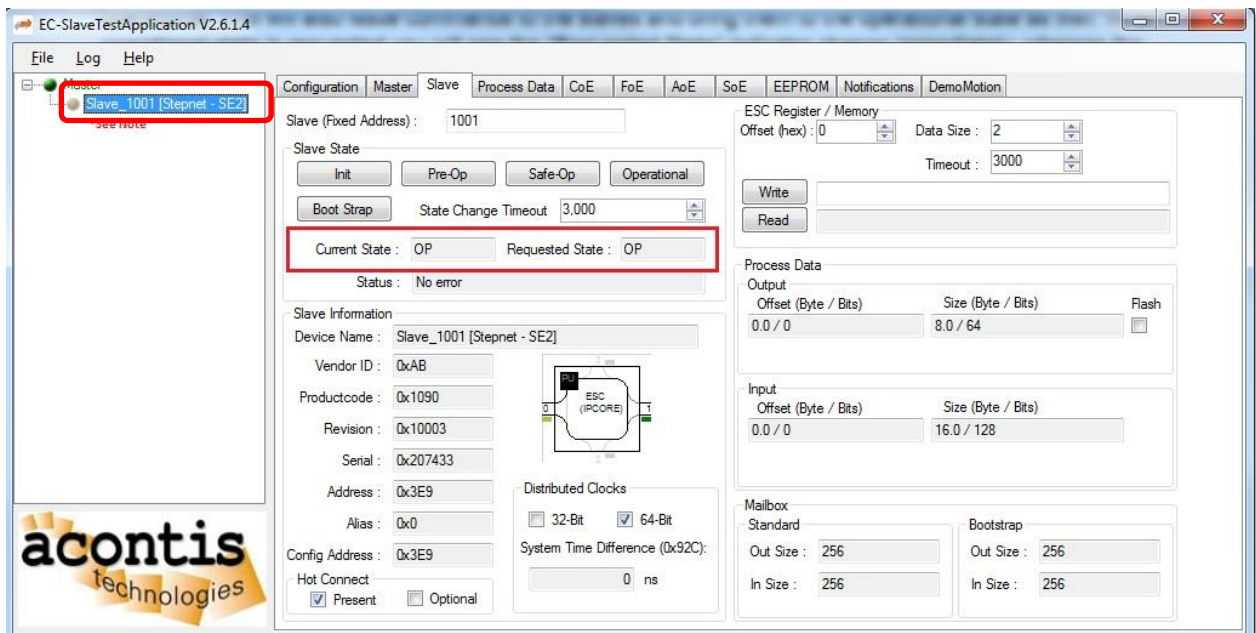

PDO Data from Master to Drive

When the slave is in the OP state, both the RPDOs and TPDOs that have been mapped will be cyclically updated. To test this, select the Process Data tab, and select “Auto Refresh” to allow the Input and Output data to update automatically. An update rate of 1000ms is fine for this example – this is simply the refresh of the GUI, not the Cycle Time of the EtherCAT master and slaves.

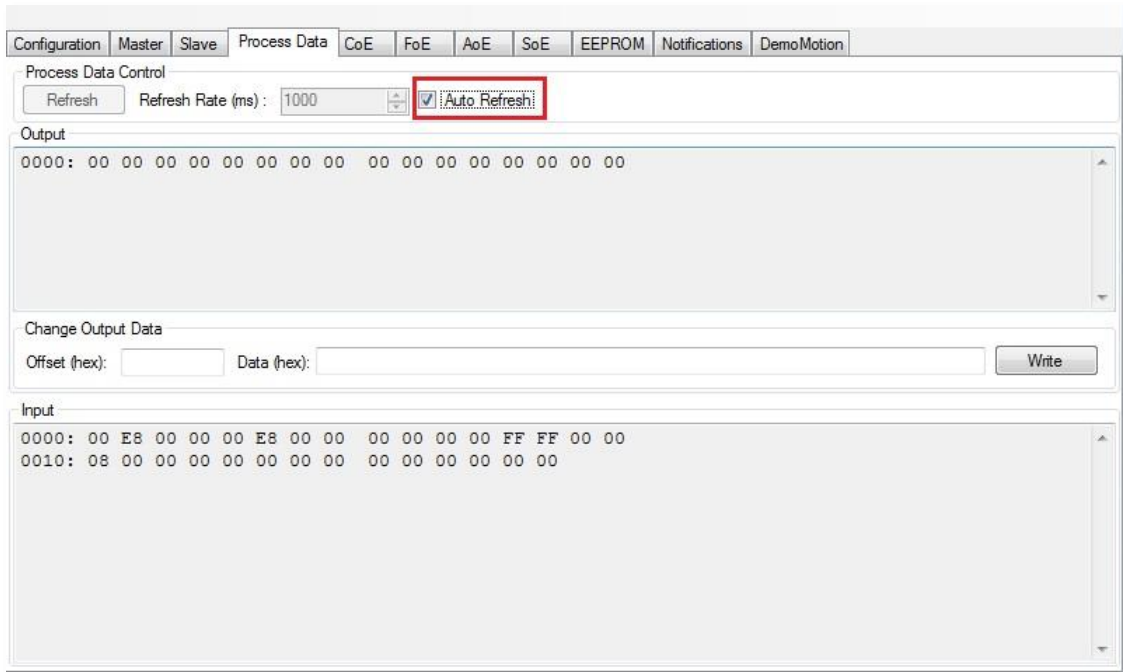

The process data is displayed as a byte stream. To understand what the byte stream is representing a good understanding of how the PDO data has been mapped is needed. For this example two RPDO’s were mapped containing the object for the commanded U and V currents of each axis. The byte stream in the output window can be broken up into 16 bit values which correlate to the parameters Axis A UV_U, Axis A UV_V, Axis B UV_U, and Axis B UV_V.

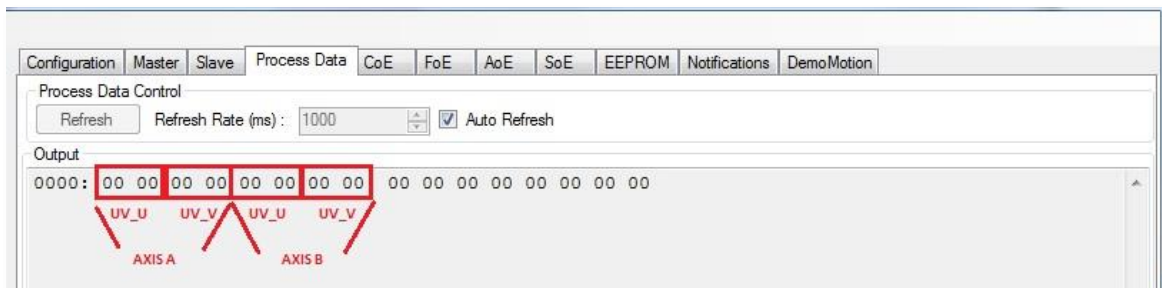

The “Change Output Data” section is used to modify the RPDO data that is cyclically sent to the slaves. With the understanding of which bytes of data correlate to which parameters on the slave it is easy to update the commanded U and V currents on the drive.

****Note:** There are two other parameters on the drive that affect how much current is produced when we write to the UV_U and UV_V parameters. For this example the UV Config register (ASCII: 0x180, EtherCAT: 0x2326) has been set to 0x103 indicating the current will be controlled via network interface and that the current commands are offset by 90°. The digital control input scaling factor (ASCII: 0xA9, EtherCAT: 0x2321) has been set to 500 indicating that 100% current produces 5A.

Set the UV_U current for Axis A and Axis B to 2.5A and the UV_V current for Axis B will be 1.25A. Axis A UV_V current will remain zero.

The output data can be updated by writing the entire by stream at once: 00 40 00 00 00 40 00 20, or it can be written to each PDO variable individually by its offset: Offset (hex): 00 Data (hex): 00 40, this would write 0x4000 (2.5A) to the UV_U parameter in the output process data.

Press “Write” to write to the output process data.

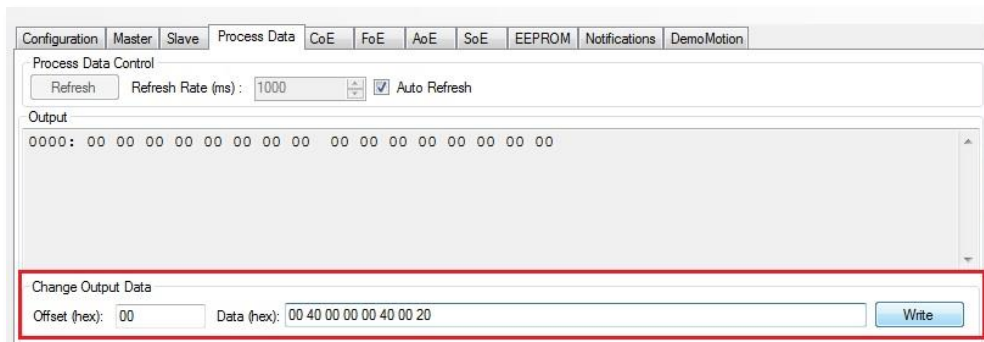

The displayed output process data should update indicating the new data to be cyclically transmitted.

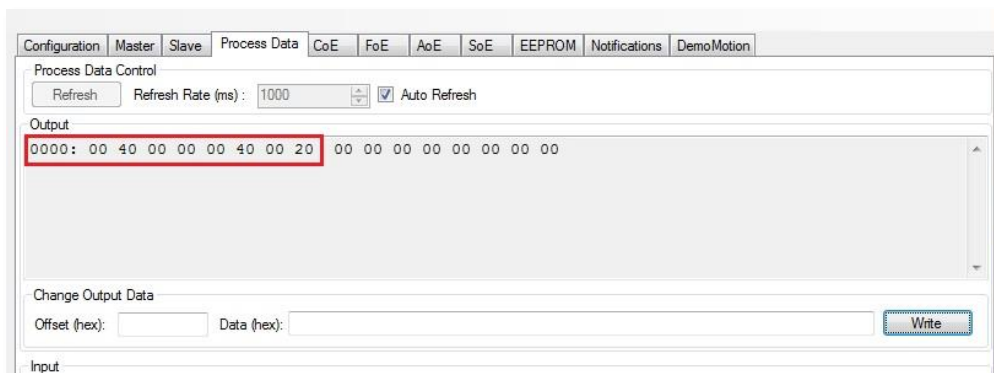

Reading the parameters for UV_U and UV_V via ASCII and CME2 for each axis confirm that the current readings have been successfully updated over the EtherCAT network.

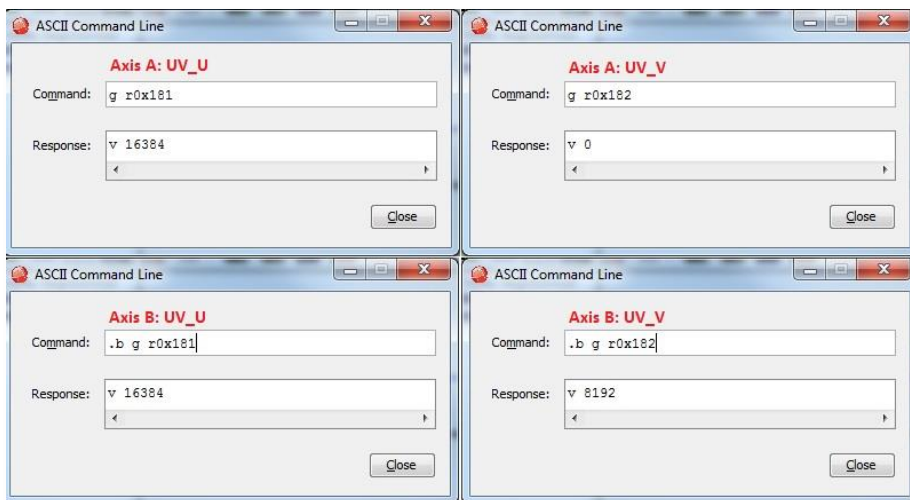

PDO Data from Drive to Master

The same principles are applied to the TPDO information located in the Input Process Data window. From the ESI file for this SE2 drive the TPDO is known to contain a 32 bit Amp Event Status word for each axis, as well as the 16 bit Actual A and Actual B currents for each axis.

The first 64 bits of the input process data will hold the Axis A and Axis B Amp Event Status information. The amplifiers are current Hardware Disabled, which is confirmed when looking at the input process data. When the amplifiers are hardware disabled, but otherwise ready to be used, the Amp Event Status should return a value of 59392 or 0xE800 hex.

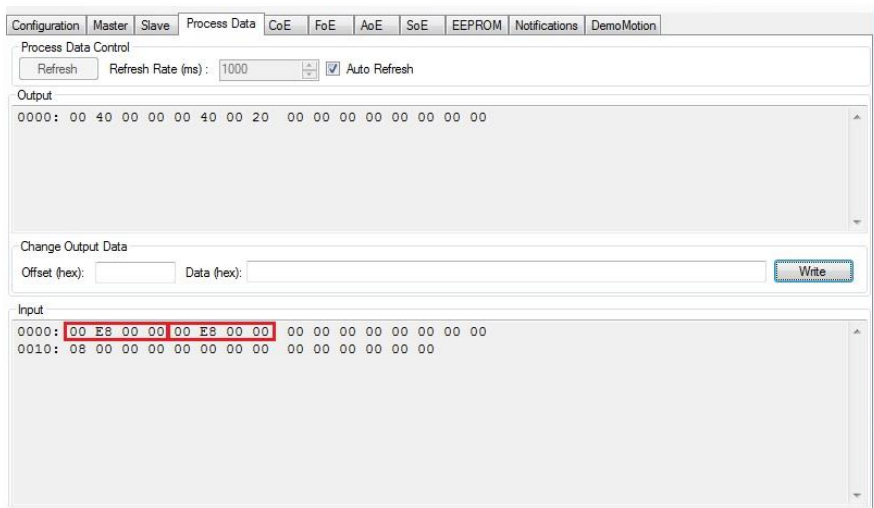

When the drives become hardware enabled, the Amp Event Status words will become zero if no errors are present, and the rest of the input process data will reflect the other objects mapped to the TPDO, specifically the actual value for the current in windings A and B of each axis.

The Amp Event Status register for each axis has cleared, and the process data shows the following currents:

- Axis A, Winding A: 00 00 -> 0A
- Axis A, Winding B: FA 00 -> 250mA -> 2.5A
- Axis B, Winding A: 7D 00 -> 124mA -> 1.25A
- Axis B, Winding B: FA 00 -> 250mA -> 2.5A

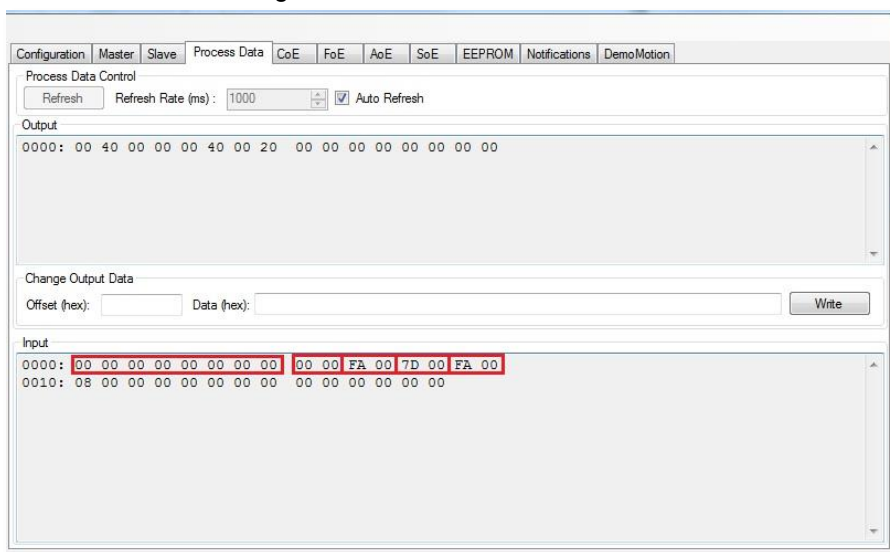

A quick check using the ASCII command line and CME2 will confirm these values.

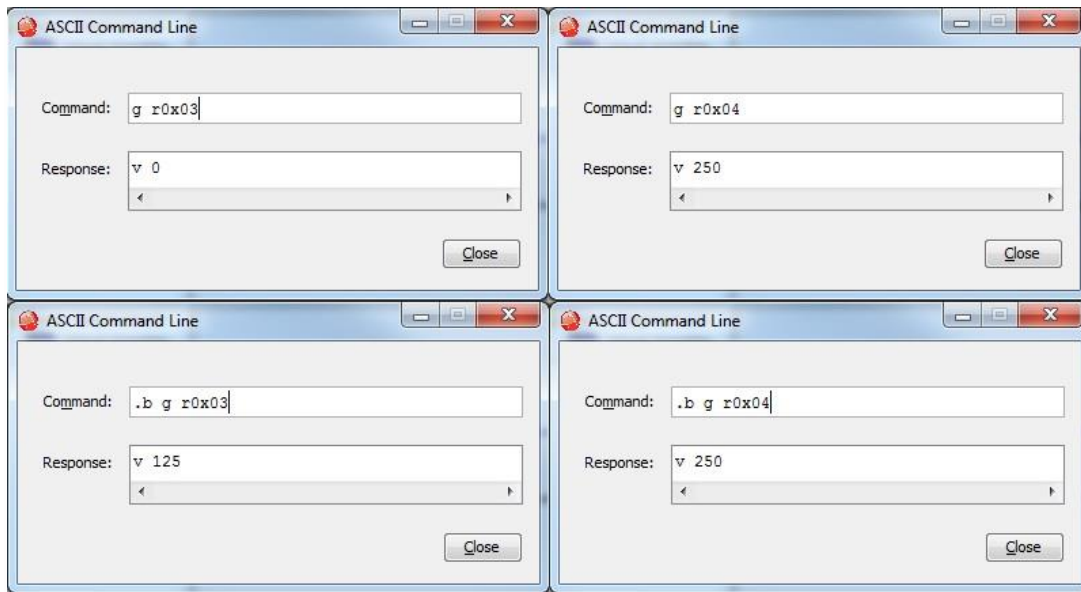

EtherCAT User Guide
P/N 16-01450 Revision 01
July 11, 2019

© 2014, 2015, 2016, 2017, 2018
Copley Controls
20 Dan Road
Canton, MA 02021 USA
<http://www.copleycontrols.com>
All rights reserved