

Brushless Motor Application Note #40

Motor Pittman GM3612B09 motor

$L_a = 0.12 \text{ mH}$, $R_a = 1.1 \Omega$, $K_t = 0.0153 \text{ Nm/A}$, $K_e = 0.0153 \text{ mV/R/S}$
 $T_{\text{cont}} = 40 \text{ mNm}$, $T_{\text{peak}} = 3\text{-}4 \times T_{\text{cont}}$, $I_{\text{cont}} = 2.6 \text{ A}$, $I_{\text{peak}} = 7.5 \text{ A}$

Amplifier 503 [Current mode]

Wiring

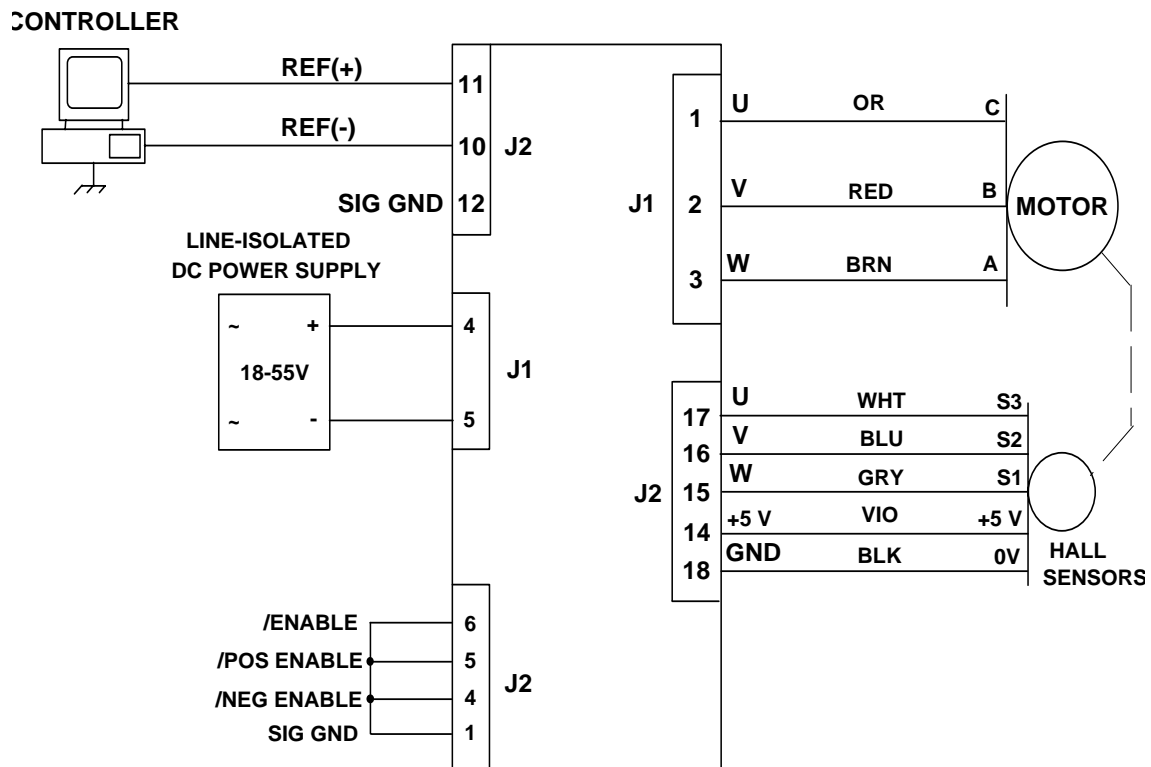

Remarks

Header Components: All others than listed below are standard.

RH1 = 49.9 K Ω Current Loop Bandwidth at 50 Vdc -3 dB = 1.2 KHz +/-20%
 CH2 = 1.5 nF With RH1, load compensation set for 0.12 mH
 RH3 = 6.04 K Ω Cont current limit = 2.6 A +/-10%
 RH5 = 6.04 K Ω Peak current limit = 7.4 A +/-10%