

## Control Modes

- Indexer, Point-to-Point, PVT
- Camming, Gearing, Position, Velocity, Torque

## Command Interface

- Stepper commands  
*Single-ended or Differential selectable*
- CANopen
- ASCII and discrete I/O
- $\pm 10V$  position/velocity/torque command
- PWM velocity/torque command
- Master encoder (Gearing/Camming)

## Communications

- CANopen
- RS232

## Feedback

- Digital quad A/B encoder
- Analog sin/cos encoder (-S versions)
- Resolver (-R versions)
- Secondary encoder / emulated encoder out
- Digital Halls

## I/O - Digital

- 12 inputs, 4 outputs

## Accessories

- External regen resistors
- External edge filter

## Dimensions: mm [in]

- 7.5 x 5.5 x 2.5 [191 x 140 x 64]



Model	Vac	Ic	Ip
XTL-230-18	100 - 240	6	18
XTL-230-36	100 - 240	12	36
XTL-230-40	100 - 240	20	40

Add -S to part numbers above for sin/cos feedback, or add -R for resolver feedback models.

## DESCRIPTION

Xenus combines CANopen networking with 100% digital control of brushless or brush motors in an off-line powered package that can operate from single or three-phase mains with continuous power output to 4 kW.

Standard models use quad A/B digital encoders for feedback. Two other versions are available for use with resolvers or sin/cos analog encoders.

Xenus operates as a Motion Control Device under the DSP-402 protocol of the CANopen DS-301 V4.01 (EN 50325-4) application layer. DSP-402 modes supported include: Profile Position, Profile Velocity, Profile Torque, Interpolated Position (PVT), and Homing.

Drive commissioning is fast and simple using CME 2 software operating under Windows® communicating with Xenus via CAN or an RS-232 link. CAN address selection is by a 16-position rotary switch on the front panel. If there are more than fifteen devices on a CAN bus, the additional address bits needed can come from programmable inputs, or can be set in flash memory. Profile Position Mode does a complete motion index on command with S-curve acceleration & deceleration, top speed, and distance programmable. In PVT mode, the controller sends out a sequence of points each of which is an increment of a larger, more complex move than a single index or profile. The drive then uses cubic polynomial interpolation to "connect the dots" such that the motor reaches each point (Position) at the specified velocity (Velocity) at the prescribed time (Time).

Homing mode is configurable to work with a variety of limit, index, and home switches such that the drive moves the motor into a position that has an absolute reference to some part of the machine. Eleven logic inputs are programmable as limit or home switches, stepper/encoder pulse inputs, reset, digital torque or velocity reference, or motor over-temperature. A twelfth input is dedicated to the drive Enable function. Three programmable logic outputs are for reporting a drive fault or other status indications. A fourth optically-isolated output can drive a motor brake from the external +24 Vdc power supply or can be programmed as a logic output.

In addition to CANopen motion commands, Xenus can operate as a stand-alone drive. Current and velocity modes accept  $\pm 10$  Vdc analog, digital 50% PWM or PWM/polarity inputs. In position mode inputs can be incremental position commands from step-motor controllers in Pulse/Direction or CW/CCW format,  $\pm 10$  Vdc analog, or A/B quadrature commands from a master-encoder. Pulse to position ratio is programmable for electronic gearing. Power output of the drive varies with the input power which can range from 100 to 240 Vac, and from 47 to 63 Hz. Either single or three phase mains can be used giving Xenus the ability to work in the widest possible range of industrial settings. Signal and control circuits are isolated from the high-voltage power supply and inverter stage that connect to the mains. A +24 Vdc input powers control circuits for keep-alive operation permitting the drive power stage to be completely powered down without losing position information or communications with the control system.

**GENERAL SPECIFICATIONS**

Test conditions: Wye connected load: 2 mH line-line. Ambient temperature = 25 °C. Power input = 230 Vac, 60 Hz, 1 Ø

MODEL	XTL-230-18	XTL-230-36	XTL-230-40	Same specs for -S and -R models
<b>OUTPUT CURRENT</b>				
Peak Current	18 (12.7)	36 (25.5)	40 (28.3)	Adc (Arms, sinusoidal)
Peak time	1	1	1	s
Continuous current (Note 1)	6 (4.24)	12 (8.5)	20 (14.1)	Adc (Arms, sinusoidal)
<b>INPUT POWER</b>				
Mains voltage, phase, frequency	100~240			Vac, ±10%, 1 Ø or 3 Ø, 47~63 Hz
Maximum Mains Current, 1Ø (Note 3)	10.1	20.0	20.0	Arms
Maximum Mains current, 3Ø (Note 3)	6.4	10.4	15.4	Arms
+24 Vdc Control power	+20 to +32 Vdc, 500 mA max			Required for operation
<b>DIGITAL CONTROL</b>				
Digital Control Loops	Current, velocity, position. 100% digital loop control			
Sampling rate (time)	Current loop: 15 kHz (67 µs), Velocity & position loops: 3 kHz (333 µs)			
Commutation	Sinusoidal field-oriented control or trapezoidal for brushless motors			
Bandwidth	Current loop: 2.5 kHz typical, bandwidth will vary with tuning & load inductance			
Bus voltage compensation	Changes in bus or mains voltage do not affect bandwidth			
Minimum load inductance	200 µH line-line			
<b>COMMAND INPUTS (NOTE: DIGITAL INPUT FUNCTIONS ARE PROGRAMMABLE)</b>				
<i>Distributed Control Modes</i>				
CANopen	Position, Velocity, Torque, Homing, Profile, and Interpolated profile modes			
ASCII	Multiple drives accessible from a single RS-232 port			
<i>Stand-alone mode</i>				
Analog torque, velocity, position reference	±10 Vdc, 12 bit resolution		Dedicated differential analog input	
Input impedance	74.8 kΩ		Between Ref(+), Ref(-)	
Digital position reference	Pulse/Direction, CW/CCW		Stepper commands (2 MHz maximum rate)	
	Quad A/B Encoder		2 M line/sec, 8 Mcount/sec (after quadrature)	
Digital torque & velocity reference	PWM, Polarity		PWM = 0% - 100%, Polarity = 1/0	
	PWM 50%		PWM = 50% ±50%, no polarity signal required	
	PWM frequency range		1 kHz minimum, 100 kHz maximum	
	PWM minimum pulse width		220 ns	
Indexing	Up to 32 programs can be launched from inputs or ASCII commands. Each program can consist of moves, I/O commands, time delays, and other programmable operations.			
Camming	Master quadrature encoder provides position as index to cam table. Digital inputs initiate cam functions.			
<b>DIGITAL INPUTS</b>				
Number	12			
Inputs [IN1~5,11,12]	74HC14 Schmitt trigger, 330 µs RC filter, Vin-LO < 1.35 Vdc, Vin-HI > 3.65 Vdc, +24 Vdc max			
Input [IN6]	[IN1] dedicated to drive enable function, other inputs are programmable			
Inputs [IN7~10]	74HC14 Schmitt trigger, 100 ns RC filter, Vin-LO < 1.35 Vdc, Vin-HI > 3.65 Vdc, +12 Vdc max			
All inputs	Single-ended: Comparator with 2.5 Vdc reference, 100 ns RC filter, Vin-LO < 2.3 Vdc, Vin-HI > 2.45 Vdc Differential: RS-485 line receiver on input pairs [IN9-7], and [IN10-8], 100 ns RC filters, +12 Vdc max 10 kΩ pull-up to +5 Vdc or pull-down to ground, selectable in groups, active level programmable			
<b>DIGITAL OUTPUTS (NOTE 2)</b>				
Number	4			
[OUT1], [OUT2], [OUT3]	Current-sinking MOSFET with 1 kΩ pullup to +5 Vdc through diode			
Current rating	1 Adc max, +40 Vdc max. Functions programmable			
Brake [OUT4]	External flyback diode required if driving inductive loads Opto-isolated, current-sinking with flyback diode to +24 Vdc, 1 Adc max			
<b>MULTI-MODE ENCODER PORT</b>				
As Input	Secondary digital quadrature encoder (A, /A, B, /B, X, /X), 121 Ω terminating resistors 18 M-counts/sec, post-quadrature (4.5 M-lines/sec)			
As Output	Primary increment encoder for models with -S option that use sin/cos signals as analog Halls Quadrature encoder emulation with programmable resolution to 4096 lines (65,536 counts) per rev from analog sin/cos encoders or resolvers. Buffered signals from digital quad A/B/X primary encoder A, /A, B, /B, X, /X, from 26C31 differential line driver			
<b>RS-232 PORT</b>				
Signals	RxD, TxD, Gnd in 6-position, 4-contact RJ-11 style modular connector			
Mode	Full-duplex, DTE serial communication port for drive setup and control, 9,600 to 115,200 baud			
Protocol	Binary and ASCII formats			
<b>CAN PORTS</b>				
Signals	CANH, CANL, Gnd in 8-position RJ-45 style modular connector, wired as per CAN Cia DR-303-1, V1.1			
Format	CAN V2.0b physical layer for high-speed connections compliant			
Data	CANopen Device Profile DSP-402			
Address selection	16 position rotary switch on front panel with 3 additional address bits available as digital inputs or programmable to flash memory (7-bit addressing, 127 nodes per CAN network)			
<b>STATUS INDICATORS</b>				
Drive Status	Bicolor LED, drive status indicated by color, and blinking or non-blinking condition			
CAN Status	Bicolor LED, status of CAN bus indicated by color and blink codes to CAN Indicator Specification 303-3			
<b>REGENERATION</b>				
Operation	Internal solid-state switch drives external regen resistor (see Ordering Guide for types)			
Cut-In Voltage	+HV > 390 Vdc	Regen output is on, (optional external) regen resistor is dissipating energy		
Drop-Out Voltage	+HV < 380 Vdc	Regen output is off, (optional external) regen resistor not dissipating energy		
Tolerance	±2 Vdc	For either Cut-In or Drop-Out voltage		

**NOTES:**

1. Heatsinking and/or forced-air cooling is required for continuous output power rating
2. Brake[OUT4] is programmable as motor brake, or as general purpose digital output
3. The actual mains current is dependent on the mains voltage, number of phases, and motor load and operating conditions. The Maximum Mains Currents shown above occur when the drive is operating from the maximum input voltage and is producing the rated continuous output current at the maximum output voltage.

## GENERAL SPECIFICATIONS (CONTINUED)

### PROTECTIONS

HV Overvoltage	+HV > 400 Vdc	Drive PWM outputs turn off until +HV is less than overvoltage
HV Undervoltage	+HV < 60 Vdc	Drive PWM outputs turn off until +HV is greater than undervoltage
Drive over temperature	IGBT > 80 °C ±3 °C	Drive PWM outputs turn off until IGBT temperature is below threshold
Short circuits	Output to output, output to ground, internal PWM bridge faults	
I <sup>2</sup> T Current limiting	Programmable: continuous current, peak current, peak time	
Motor over temperature	Drive shuts down when motor over-temperature switch changes to high-resistance state, or opens	
Encoder power loss	A Feedback Error fault occurs if encoder+5V output is <4.55 Vdc	

### MECHANICAL & ENVIRONMENTAL

Size	7.55 in (191,8 mm) X 5.57 in (141,5 mm) X 2.57 in (65,3 mm)	
Weight	3.0 lb (1.36 kg) for drive without heatsink 1.9 lb (0.86 kg) for XTL-HS heatsink, 1.26 lb (0.57 kg) for XTL-HL heatsink	
Ambient temperature	0 to +45 °C operating, -40 to +85 °C storage	
Humidity	0% to 95%, non-condensing	
Vibration	2 g peak, 10~500 Hz (sine), IEC60068-2-6	
Shock	10 g, 10 ms, half-sine pulse, IEC60068-2-27	
Contaminants	Pollution degree 2	
Environment	IEC68-2: 1990	
Cooling	Heat sink and/or forced air cooling required for continuous power output	

### AGENCY STANDARDS CONFORMANCE

EN 55011 : 1998	CISPR 11 (1997) Edition 2/Amendment 2: Limits and Methods of Measurement of Radio Disturbance Characteristics of Industrial, Scientific, and Medical (ISM) Radio Frequency Equipment
EN 61000-6-1 : 2001	Electromagnetic Compatibility Generic Immunity Requirements <i>Following the provisions of EC Directive 89/336/EEC:</i>
EN 61010-1 2nd Ed.: 2004	Safety Requirements for Electrical Equipment for Measurement, Control, and Laboratory use <i>Following the provisions of EC Directive 2006/95/EC:</i>
UL 508C 3rd Ed.: 2002	UL Standard for Safety for Power Conversion Equipment

## FEEDBACK SPECIFICATIONS

### ENCODER

#### DIGITAL QUAD A/B ENCODER

Type	Quadrature, differential line driver outputs
Signals	A, /A, B, /B, X, /X, index signals optional
Frequency	5 MHz line frequency, 20 MHz quadrature count frequency

#### ANALOG ENCODER

Type	Sin/cos, differential line driver outputs, 0.5 V <sub>peak-peak</sub> (1.0 V <sub>peak-peak</sub> differential) centered about 2.5 Vdc typical. Common-mode voltage 0.25 to 3.75 Vdc
Signals	Sin(+), sin(-), cos(+), cos(-)
Frequency	230 kHz maximum line (cycle) frequency
Interpolation	10 bits/cycle (1024 counts/cycle)

#### DIGITAL HALLS

Type	Digital, single-ended, 120° electrical phase difference
Signals	U, V, W
Frequency	Consult factory for speeds >10,000 RPM

#### ANALOG HALLS

Type	HA/HB, differential line driver outputs, 0.5 V <sub>peak-peak</sub> (1.0 V <sub>peak-peak</sub> differential) centered about 2.5 Vdc typical. Common-mode voltage 0.25 to 3.75 Vdc
Signals	HA(+), HA(-), HB(+), HB(-) Use Multi-mode port as primary incremental encoder input for position feedback

#### ENCODER POWER SUPPLY

Power Supply	+5 Vdc @ 400 mA to power encoders & Halls
Protection	Current-limited to 750 mA @ 1 Vdc if overloaded Encoder power developed from +24 Vdc so position information is not lost when AC mains power is removed

#### MOTOR CONNECTIONS

Phase U, V, W	PWM outputs to 3-phase ungrounded Wye or delta connected brushless motors
Hall U, V, W	Hall signals
Digital Encoder	A, /A, B, /B, X, /X, on standard models
Analog Encoder	Sin(+), sin(-), cos(+), cos(-), X, /X, on -S versions (X & /X index signals are digital)
Hall & encoder power	+5 Vdc @ 400 mA maximum
Motemp [IN5]	Motor overtemperature sensor input, 4.99 kΩ to +5 Vdc or ground
Signal ground	Return for encoder, Halls, and temperature sensor
Brake [OUT4]	Current-sinking motor brake driver
+24 Vdc	From drive +24 Vdc power supply to power motor brake
Frame ground	For motor cable shield

## FEEDBACK SPECIFICATIONS (CONTINUED)

### RESOLVER

#### RESOLVER

Type	Brushless, single-speed, 1:1 to 2:1 programmable transformation ratio
Resolution	14 bits (equivalent to a 4096 line quadrature encoder)
Reference frequency	7.5 kHz
Reference voltage	2.8 Vrms, auto-adjustable by the drive to maximize feedback
Reference maximum current	100 mA
Maximum RPM	10,000+

#### ENCODER EMULATION

Resolution	Programmable to 16,384 counts/rev (4096 line encoder equivalent)
Buffered encoder outputs	26C31 differential line driver

### MOTOR CONNECTIONS

Phase U, V, W	PWM outputs to 3-phase ungrounded Wye or delta connected brushless motors
Resolver	R1, R2, S1, S2, S3, S4
Motemp [IN5]	Motor overtemperature sensor input. Active level programmable. 4.99 kΩ to +5 Vdc or ground Disables drive when motor over-temperature condition occurs Same input circuit as GP digital inputs
Signal ground	Return for temperature sensor
Brake [OUT4]	Current-sinking motor brake driver
+24 Vdc	From drive +24 Vdc power supply to power motor brake
Frame ground	For motor cable shield

### DIMENSIONS

Inches (mm)

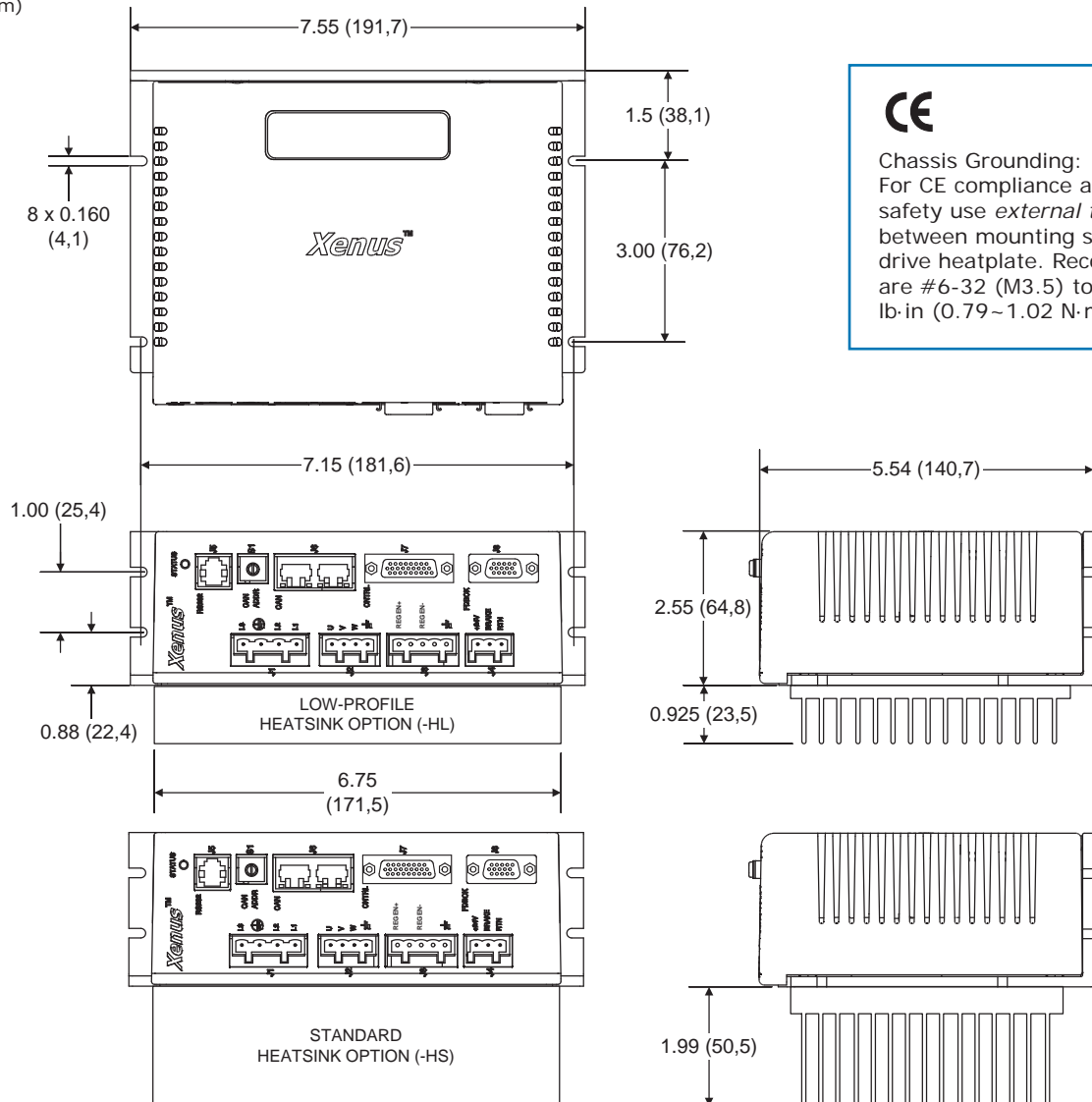

**Chassis Grounding:**  
For CE compliance and machine safety use *external tooth* lockwashers between mounting screw head and drive heatplate. Recommended screws are #6-32 (M3.5) torqued to 8~10 lb-in (0.79~1.02 N·m).

## COMMUNICATIONS

### CME 2 SOFTWARE

Drive setup is fast and easy using CME 2 software communicating via RS-232 or over the CAN bus. All of the operations needed to configure the drive are accessible through this powerful and intuitive program. Auto-phasing of brushless motor Hall sensors and phase wires eliminates “wire and try”. Connections are made once and CME 2 does the rest thereafter. Encoder wire swapping to establish the direction of positive motion is eliminated.

Motor data can be saved as .ccm files. Drive data is saved as .ccx files that contain all drive settings plus motor data. This eases system management as files can be cross-referenced to drives. Once a drive configuration has been completed systems can be replicated easily with the same setup and performance. When operating as a stand-alone drive that takes command inputs from an external controller, CME 2 is used for configuration. When operated as a CAN node, CME 2 can be used for programming before and after installation in a CAN network. Xenus can also be controlled via CME 2 while it is in place as a CAN node. During this process, drive operation as a CAN node is suspended. When adjustments are complete, CME 2 relinquishes control of the drive and returns it to the CAN node state.

### RS-232

Xenus operates as a DTE device from a three-wire, full-duplex RS-232 port at 9,600 to 115,200 Baud, 8 bits, no parity, and one stop bit. The SER-CK Serial Cable Kit provides an adapter that connects to the COMM port of a PC (a 9 position, male D-Sub connector) and accepts a modular cable with RJ-11 connectors for connection to the Xenus RS-232 port (J6).

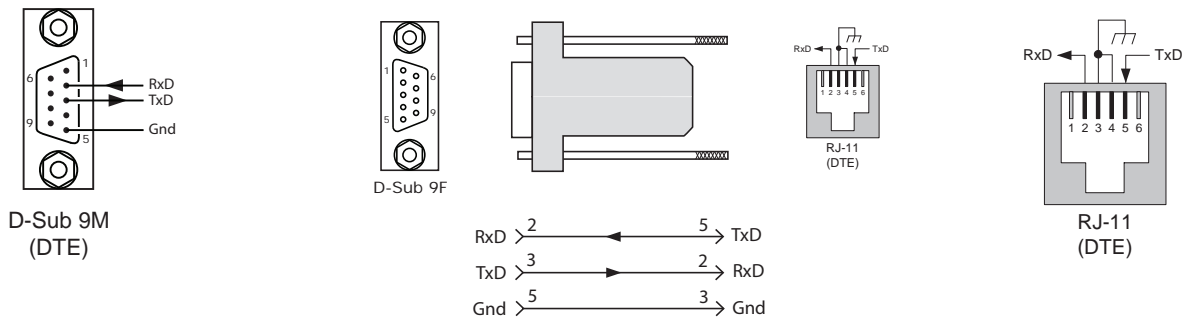

PC COMM PORT SIGNALS

SER-CK SERIAL CABLE KIT ADAPTER CONNECTIONS

J5 SIGNALS

### RS-232 MULTI-DROP

The RS-232 specification makes no allowance for more than two devices on a serial link. But, multiple Xenus drives can communicate over a single RS-232 port by daisy-chaining a master drive to other drives using CAN cables. In the CAN protocol, address 0 is reserved for the CAN master and thereafter all other nodes on a CAN network must have unique, non-zero addresses. When the Xenus CAN address is set to 0, it acts as a CAN master, converting the RS-232 data into CAN messages and passing it along to the other drives which act as CAN nodes.

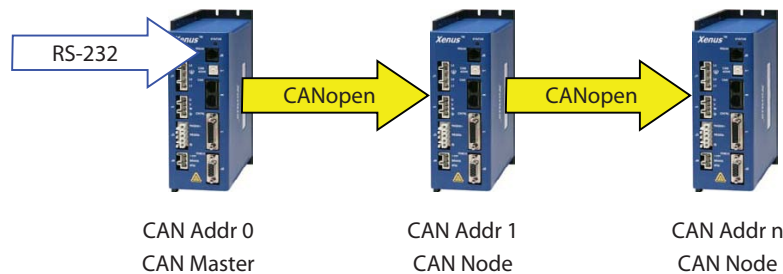

### ASCII COMMUNICATIONS

The Copley ASCII Interface is a set of ASCII format commands that can be used to operate and monitor Copley Controls Accelnet, Stepnet, and Xenus series amplifiers over an RS-232 serial connection. For instance, after basic amplifier configuration values have been programmed using CME 2, a control program can use the ASCII Interface to:

- Enable the amplifier in Programmed Position mode.
- Home the axis.
- Issue a series of move commands while monitoring position, velocity, and other run-time variables.

Additional information can be found in the ASCII Programmers Guide on the Copley website:  
[http://www.copleycontrols.com/motion/downloads/pdf/ASCII\\_ProgrammersGuide.pdf](http://www.copleycontrols.com/motion/downloads/pdf/ASCII_ProgrammersGuide.pdf)

## COMMUNICATIONS (CONTINUED)

### CANOPEN

Based on the CAN V2.0b physical layer, a robust, two-wire communication bus originally designed for automotive use where low-cost and noise-immunity are essential, CANopen adds support for motion-control devices and command synchronization. The result is a highly effective combination of data-rate and low cost for multi-axis motion control systems. Device synchronization enables multiple axes to coordinate moves as if they were driven from a single control card.

### CANOPEN COMMUNICATION

Xenus uses the CAN physical layer signals CANH, CANL, and GND for connection, and CANopen protocol for communication. Before installing the drive in a CAN system, it must be assigned a CAN address. A maximum of 127 CAN nodes are allowed on a single CAN bus. The rotary switch on the front panel controls the four lower bits of the seven-bit CAN address. When the number of nodes on a bus is less than sixteen, the CAN address can be set using only the switch.

For installations with sixteen or more CAN nodes on a network CME 2 can be used to configure Xenus to use the rotary switch, or combinations of digital inputs and programmed offset in flash memory to configure the drive with a higher CAN node address. For more information on CANopen communications, download the CANopen Manual from the Copley web-site: <http://www.copleycontrols.com/motion/downloads/pdf/CANopenProgrammersManual.pdf>

### CANOPEN CONNECTORS

Dual RJ-45 connectors that accept standard Ethernet cables are provided for CAN bus connectivity. Pins are wired-through so that drives can be daisy-chained and controlled with a single connection to the user's CAN interface. A CAN terminator should be placed in the last drive in the chain. The XTL-NK connector kit provides a D-Sub adapter that plugs into a CAN controller and has an RJ-45 socket that accepts the Ethernet cable.

### XTL-NK CAN CONNECTOR KIT

The kit contains the XTL-CV adapter that converts the CAN interface D-Sub 9M connector to an RJ-45 Ethernet cable socket, plus a 10 ft (3 m) cable and terminator. Both connector pin-outs conform to the CiA DR-303-1 specification.

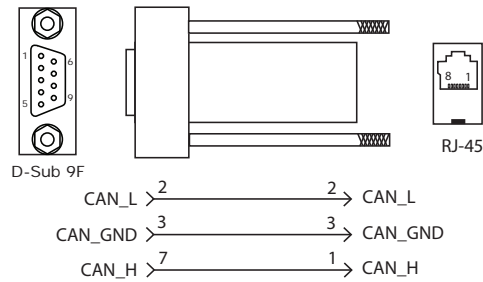
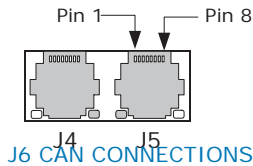

### CAN STATUS LED

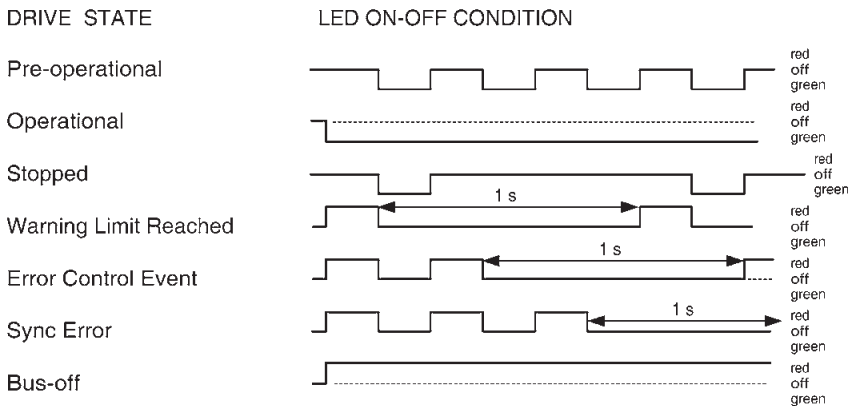

Note: Red & green led on-times do not overlap.  
LED color may be red, green, off, or flashing of either color.

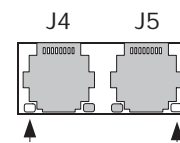

## COMMUNICATIONS (CONTINUED)

### DRIVE STATUS LED

A single bi-color LED gives the state of the drive by changing color, and either blinking or remaining solid.

The possible color and blink combinations are:

- *Green/Solid:* Drive OK and enabled. Will run in response to reference inputs or CANopen commands.
- *Green/Slow-Blinking:* Drive OK but NOT-enabled. Will run when enabled.
- *Green/Fast-Blinking:* Positive or Negative limit switch active. Drive will only move in direction not inhibited by limit switch.
- *Red/Solid:* Transient fault condition. Drive will resume operation when fault is removed.
- *Red/Blinking:* Latching fault. Operation will not resume until drive is Reset.

#### Drive Fault conditions:

- Over or under-voltage
- Motor over-temperature
- Encoder +5 Vdc fault
- Short-circuits from output to output
- Short-circuits from output to ground
- Internal short circuits
- Drive over-temperature

Faults are programmable to be either transient or latching

## COMMAND INPUTS

### ANALOG REFERENCE INPUT

A single  $\pm 10$  Vdc differential input takes inputs from controllers that use PID or similar compensators, and outputs a current command to the drive. Drive output current or velocity vs. reference input voltage is programmable.

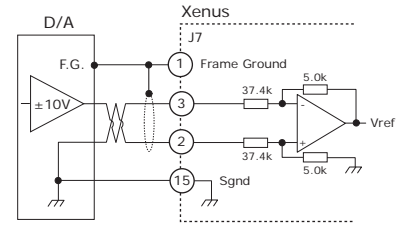

### DIGITAL POSITION

Digital position commands can be in either single-ended or differential format. Single-ended signals should be sourced from devices with active pull-up and pull-down to take advantage of the high-speed inputs. Differential inputs have 121  $\Omega$  line-terminators.

#### SINGLE-ENDED PULSE & DIRECTION

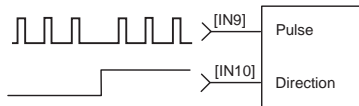

#### DIFFERENTIAL PULSE & DIRECTION

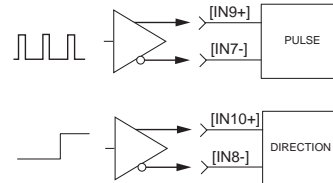

#### SINGLE-ENDED CU/CD

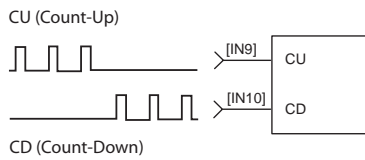

#### DIFFERENTIAL CU/CD

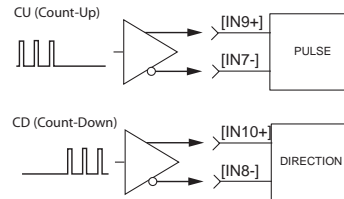

#### QUAD A/B ENCODER SINGLE-ENDED

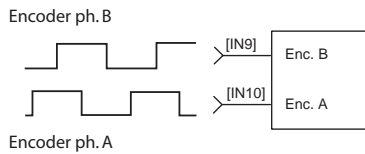

#### QUAD A/B ENCODER DIFFERENTIAL

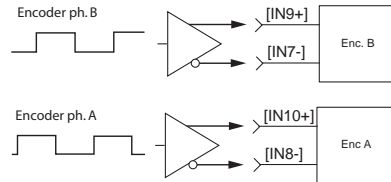

### DIGITAL TORQUE, VELOCITY

Digital torque or velocity commands can be in either single-ended or differential format. Single-ended signals must be sourced from devices with active pull-up and pull-down to take advantage of the high-speed inputs.

#### SINGLE-ENDED PWM & DIRECTION

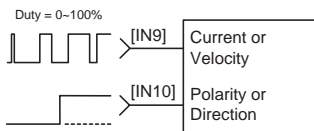

#### DIFFERENTIAL PWM & DIRECTION

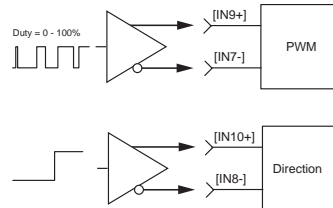

#### SINGLE-ENDED 50% PWM

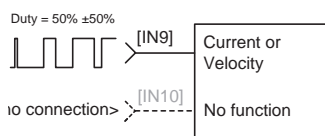

#### DIFFERENTIAL 50% PWM

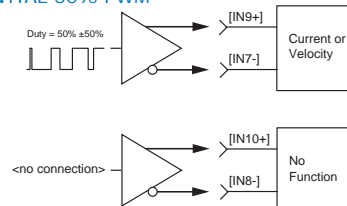

## COMMAND INPUTS (CONTINUED)

### DIGITAL INPUTS

Xenus has twelve digital inputs, eleven of which have programmable functions. Input [IN1] is dedicated to the drive Enable function. This is done to prevent accidental programming of the input in such a way that the controller could not shut it down.

Two types of RC filters are used: GP (general purpose) and HS (high speed). Input functions such as Pulse/Dir, CW/CCW, Quad A/B are wired to inputs having the HS filters, and inputs with the GP filters are used for general purpose logic functions, limit switches, and the motor temperature sensor. Programmable functions of the digital inputs include:

- Positive Limit switch
- Negative Limit switch
- Home switch
- Drive Reset
- PWM current or velocity commands
- CAN address bits
- Step & Direction, or CU/CD step motor position commands
- Quad A/B master encoder position commands
- Motor over-temperature
- Motion Profile Abort

### PULL-UP/PULL-DOWN CONTROL

In addition to the active level and function for each programmable input, the input resistors are programmable in four groups to either pull up to +5 Vdc, or down to ground. Grounded inputs with HI active levels interface to PLC's that have PNP outputs that source current from +24 Vdc sources. Inputs pulled up to +5 Vdc work with open-collector, or NPN drivers that sink current to ground. The table below shows the PU/PD groups and the inputs they control.

Group	Inputs
A	1,2,3
B	4,5
C	6,7,8
D	9,10,11,12

### DIGITAL INPUT CIRCUITS

#### 24VDC MAX

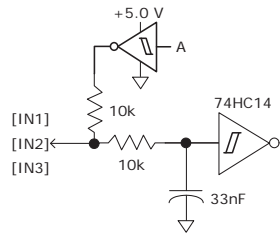

#### 24VDC MAX

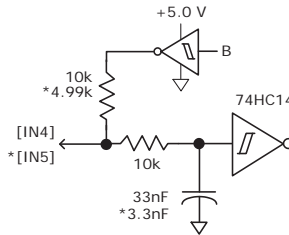

### HS (HIGH SPEED) DIGITAL INPUTS

These inputs have all the programmable functions of the GP inputs plus these additional functions on [IN8] & [IN9] which can be configured as single-ended or differential:

- PWM 50%, PWM & Direction for Velocity or Current modes
- Pulse/Direction, CU/CD, or A/B Quad encoder inputs for Position or Camming modes

[IN6-10] 12 VDC MAX, [IN12-13] 24 VDC MAX

#### SINGLE-ENDED

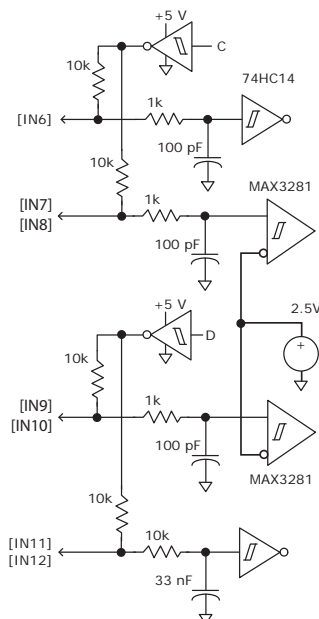

#### DIFFERENTIAL

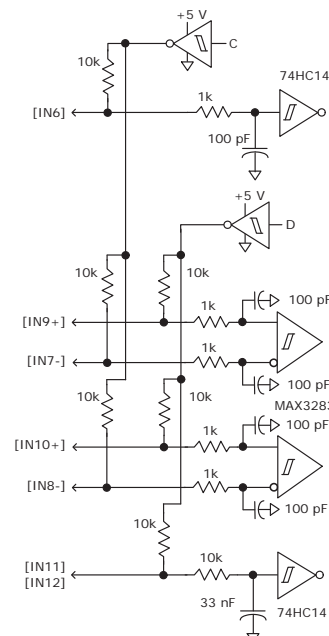

## OUTPUTS

### DIGITAL OUTPUTS

The digital outputs are open-drain MOSFETs with 1 kΩ pull-up resistors in series with a diode to +5 Vdc. They can sink up to 1 Adc from external loads operating from power supplies to +30 Vdc.

The output functions are programmable. The active state of the outputs is programmable to be on or off.

When driving inductive loads such as a relay, an external fly-back diode is required. The internal diode in the output is for driving PLC inputs that are opto-isolated and connected to +24 Vdc. The diode prevents conduction from +24 Vdc through the 1 kΩ resistor to +5 Vdc in the drive. This could turn the PLC input on, giving a false indication of the drive output state.

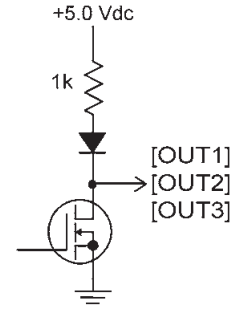

### BRAKE OUTPUT [OUT4]

This output is an open-drain MOSFET with an internal flyback diode connected to the +24 Vdc input. It can sink up to 1A from a motor brake connected to the +24 Vdc supply. The operation of the brake is programmable with CME 2. It can also be programmed as a general-purpose digital output.

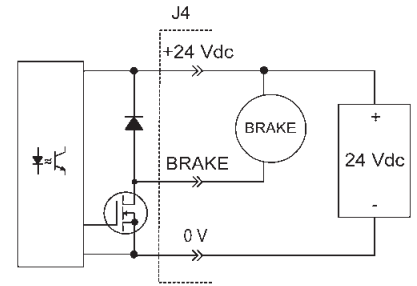

## MOTOR CONNECTIONS

Motor connections are of three types: phase, feedback, and thermal sensor. The phase connections carry the drive output currents that drive the motor to produce motion. A thermal sensor that indicates motor overtemperature is used to shut down the drive to protect the motor. Feedback can be digital quad A/B encoder, analog sin/cos encoder, resolver or digital Halls, depending on the version of the drive.

### MOTOR PHASE CONNECTIONS

The drive output is a three-phase PWM inverter that converts the DC buss voltage (+HV) into three sinusoidal voltage waveforms that drive the motor phase-coils. Cable should be sized for the continuous current rating of the motor. Motor cabling should use twisted, shielded conductors for CE compliance, and to minimize PWM noise coupling into other circuits. The motor cable shield should connect to motor frame and the drive frame ground terminal (J2-1) for best results.

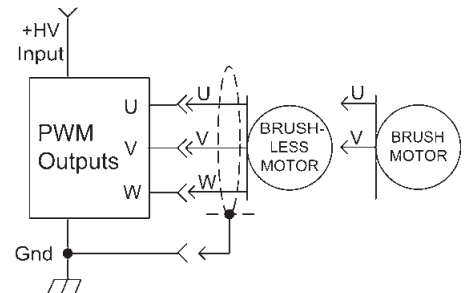

### DIGITAL HALL SIGNALS

Hall signals are single-ended signals that provide absolute feedback within one electrical cycle of the motor. There are three of them (U, V, & W) and they may be sourced by magnetic sensors in the motor, or by encoders that have Hall tracks as part of the encoder disc. They typically operate at much lower frequencies than the motor encoder signals, and are used for commutation-initialization after startup, and for checking the motor phasing after the amplifier has switched to sinusoidal commutation. Resolver models can also take Hall signal at inputs [IN6-8]. See page 15 for connections.

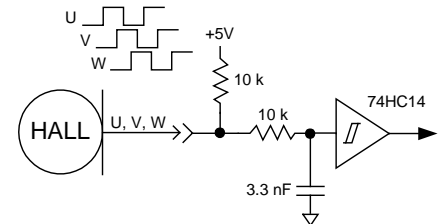

## MOTOR CONNECTIONS (CONT'D)

### DIGITAL ENCODERS

The quad A/B encoder interface is a differential line-receiver with R-C filtering on the inputs. Encoders with differential outputs are required because they are less susceptible to noise that can degrade single-ended outputs. Encoder cables should use twisted-pairs for each signal pair: A & /A, B & /B, X & /X. An overall shield should be used, and for longer cables, shields for individual pairs may be necessary to guarantee signal integrity.

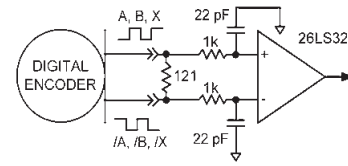

### ANALOG ENCODER (-S MODELS)

Xenus supports analog encoder signals for position feedback. The Sin and Cos inputs are differential with 121 Ω terminating resistors and accept 1.0 Vp-p signals in the A/B format used by encoders with analog outputs such as Heidenhain, Stegman, and Renishaw. When Copley's ServoTube motors are used the analog encoder supplies both commutation and incremental position feedback.

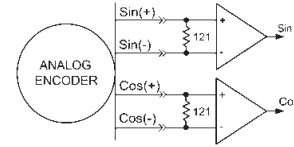

### ANALOG HALLS (-S MODELS) + DIGITAL ENCODER

For position feedback with higher resolution than is possible by interpolating analog Halls, a digital incremental encoder is connected to the multi-mode port. The Halls are then used for commutation and the multi-mode port is programmed as a differential input for the Secondary Incremental motor encoder.

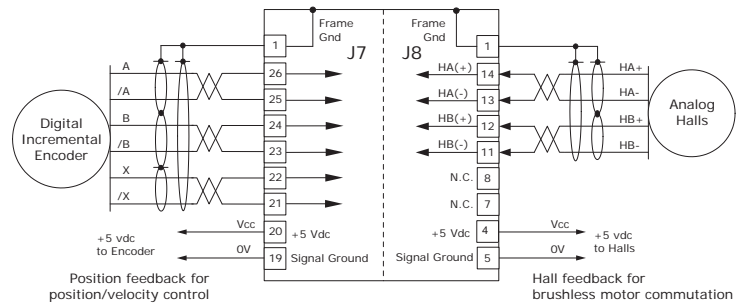

### RESOLVER (-R MODELS)

Connections to the resolver should be made with shielded cable that uses three twisted-pairs. Once connected, resolver set up, motor phasing, and other commissioning adjustments are made with CME 2 software. There are no hardware adjustments.

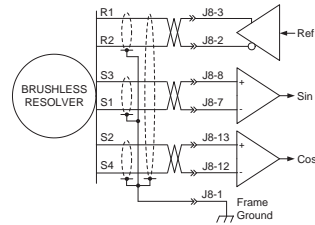

### MOTOR TEMPERATURE SENSOR

Digital input [IN5] is for use with a motor overtemperature switch. The input should be programmed as a pull-up to +5 Vdc if the motor switch is grounded when cold, and open or high-impedance when over-heating.

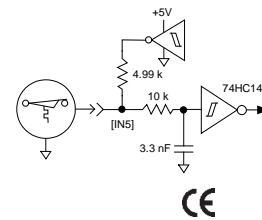

### BRAKE OUTPUT [OUT4]

This output is an open-drain MOSFET with an internal flyback diode connected to the +24 Vdc input. It can sink up to 1A from a motor brake connected to the +24 Vdc supply. The operation of the brake is programmable with CME 2. It can also be programmed as a general-purpose digital output.

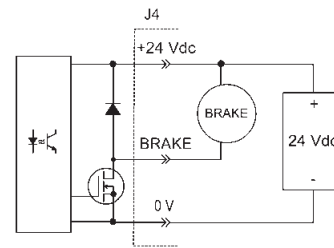

**CE** = Shielded cables required for CE compliance

## MOTOR CONNECTIONS (CONT'D)

### MULTI-MODE ENCODER PORT

This port consists of three differential input/output channels that take their functions from the Basic Setup of the drive. On drives with quad A/B encoder feedback, the port works as an output buffering the signals from the encoder. With resolver or sin/cos encoder versions, the feedback is converted to quad A/B signals with programmable resolution. These signals can then be fed back to an external motion controller that closes the position or velocity loops. As an input, the port can take quad A/B signals to produce a dual-loop position control system or use the signals as master-encoder feedback in camming mode. In addition, the port can take stepper command signals (CU/CD or Pulse/Direction) in differential format.

#### AS BUFFERED OUTPUTS FROM A DIGITAL QUADRATURE FEEDBACK ENCODER

When using a digital quadrature feedback encoder, the A/B/X signals drive the multi-mode port output buffers directly. This is useful in systems that use external controllers that also need the motor feedback encoder signals because these now come from J7, the Control connector. In addition to eliminating "Y" cabling where the motor feedback cable has to split to connect to both controller and motor, the buffered outputs reduce loading on the feedback cable that could occur if the motor encoder had to drive two differential inputs in parallel, each with it's own 121 ohm terminating resistor.

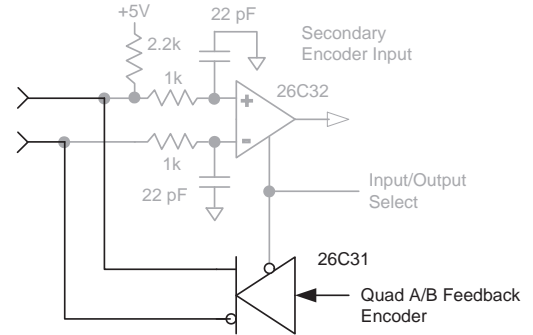

#### AS EMULATED QUAD A/B/X ENCODER OUTPUTS FROM AN ANALOG SIN/COS FEEDBACK ENCODER

Analog sin/cos signals are interpolated in the drive with programmable resolution. The incremental position data is then converted back into digital quadrature format which drives the multi-mode port output buffers. Some analog encoders also produce a digital index pulse which is connected directly to the port's output buffer. The result is digital quadrature A/B/X signals that can be used as feedback to an external control system.

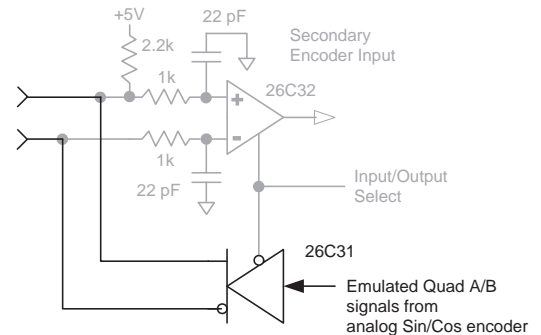

#### AS A MASTER OR CAMMING ENCODER INPUT FROM A DIGITAL QUADRATURE ENCODER

When operating in position mode the multi-mode port can accept digital command signals from external encoders. These can be used to drive cam tables, or as master-encoder signals when operating in a master/slave configuration.

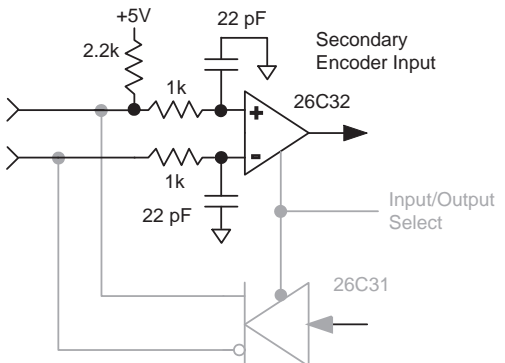

#### AS DIGITAL COMMAND INPUTS IN PULSE/DIRECTION, PULSE-UP/PULSE-DOWN, OR DIGITAL QUADRATURE ENCODER FORMAT

The multi-mode port can also be used when digital command signals are in a differential format. These are the signals that typically go to [IN9] and [IN10] when they are single-ended. But, at higher frequencies these are likely to be differential signals in which case the multi-mode port can be used.

MOTOR CONNECTIONS (CONT'D)

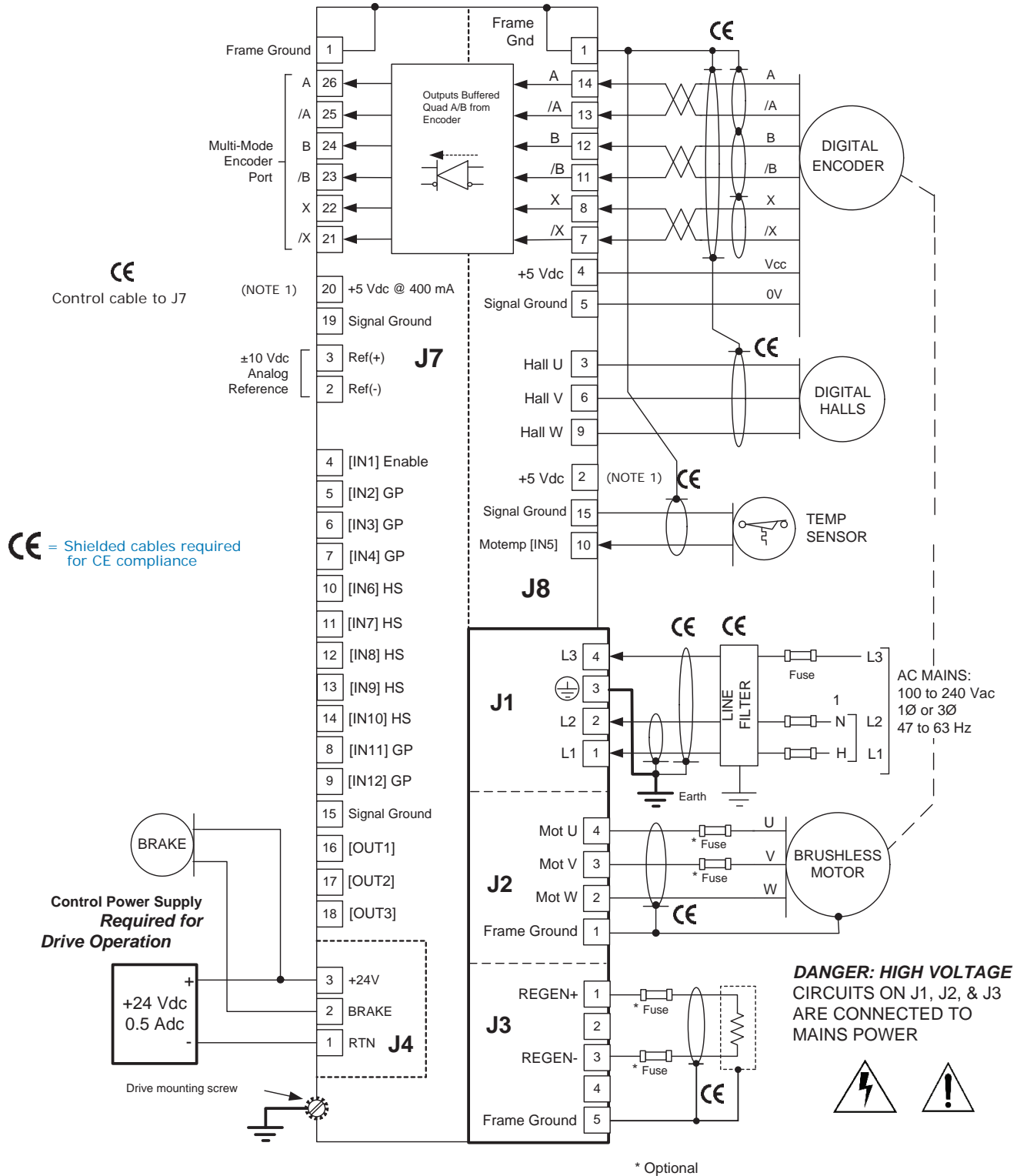

NOTES:

- 1) The total output current from the +5 Vdc supply to J7-20 cannot exceed 400 mA dc
- 2) Line filter is required for CE

MOTOR CONNECTIONS (CONT'D)

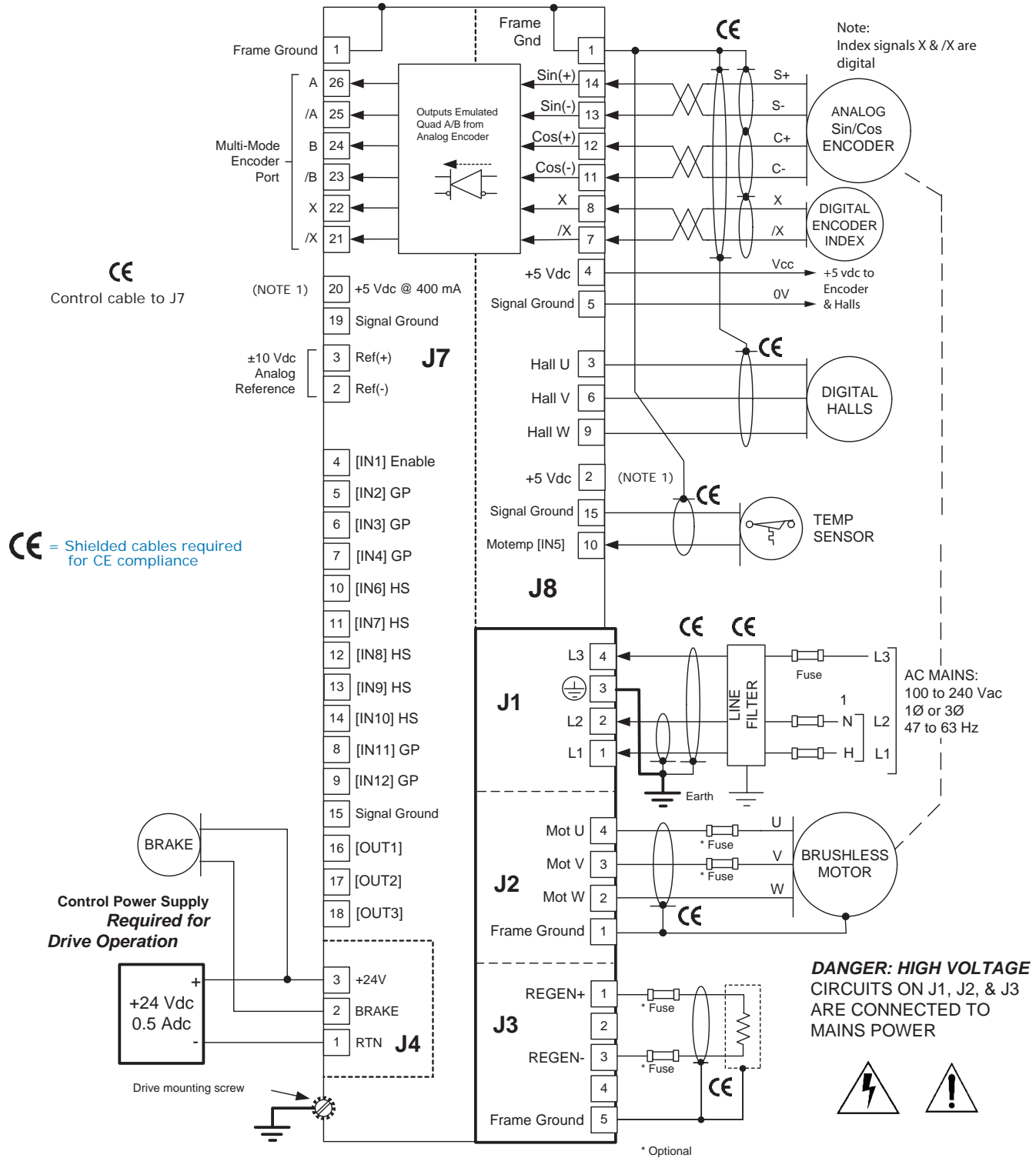

NOTES:

- 1) The total output current from the +5 Vdc supply to J7-20 cannot exceed 400 mA
- 2) Line filter is required for CE
- 3) Page 11 shows connections for analog Hall commutation with digital incremental position feedback.

MOTOR CONNECTIONS (CONT'D)

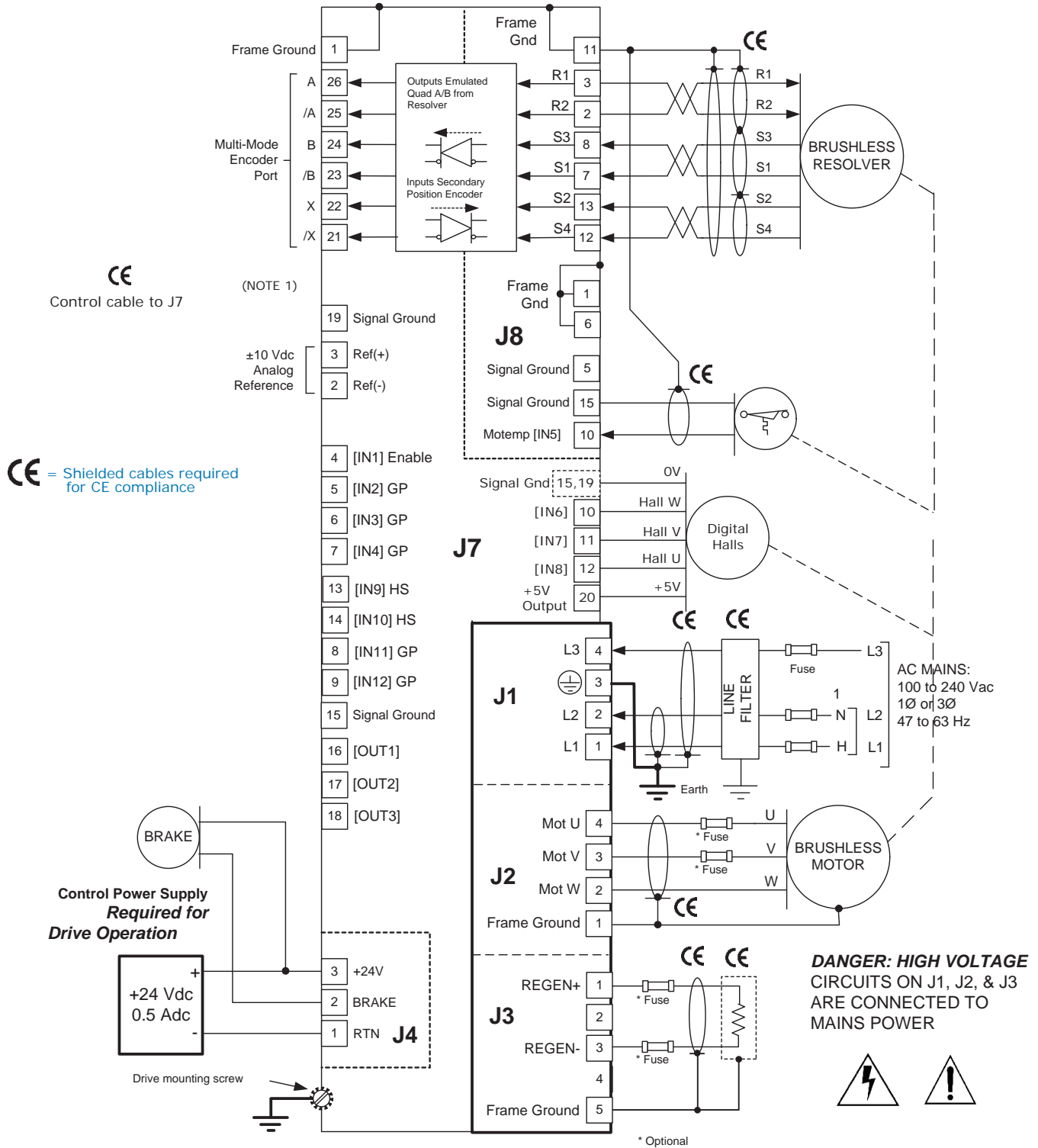

**NOTES:**

- 1) The total output current from the +5 Vdc supply to J7-20 cannot exceed 400 mA
- 2) Line filter is required for CE
- 3) Usage of [IN6~8] for Hall sensors is optional. If not used for Halls, these are programmable, high-speed inputs. Signal Ground for Halls can use J7-15, J7-19, or J8-5.

## DRIVE POWER SOURCES

An external +24 Vdc power supply is required, and powers an internal DC/DC converter that supplies all the control voltages for drive operation. Use of an external supply enables CAN communication with the drive when the mains power has been removed.

Power distribution in Xenus is divided into four sections: +24 Vdc, CAN, signal, and high-voltage. Each is isolated from the other and all are isolated from the chassis.

### EXTERNAL +24 VDC

The primary side of the DC/DC converter operates directly from the external +24 Vdc supply and is isolated from other drive power sections. The Brake output [OUT4] operates in this section and is referenced to the +24 Vdc return (0V). It sinks current from an external load connected to the external +24 Vdc power source.

### INTERNAL SIGNAL POWER

The signal power section supplies power for the DSP controller as well as logic inputs and outputs. Motor feedback signals such as Halls, encoder, and temperature sensor operate from this power source. All signal circuits are referenced to signal ground. This ground should connect to the control system circuit ground or common so that drive and controller inputs and output voltage levels work properly with each other.

## MAINS POWER

Mains power drives the high-voltage section. It is rectified and capacitor-filtered to produce +HV which the PWM stage converts into voltages that drive either three phase brushless or DC brush motors. An internal solid-state switch together with an external power resistor provides dissipation during regeneration when the mechanical energy of the motor is converted back into electrical energy that must be dissipated before it charges the internal capacitors to an overvoltage condition. All the circuits in this section are "hot", that is, they connect directly to the mains and must be considered high-voltages and a shock hazard requiring proper insulation techniques during installation.

## GROUNDING

A grounding system has three primary functions: safety, voltage-reference, and shielding. As a safety measure, the primary ground at J1-3 will carry fault-currents from the mains in the case of an internal failure or short-circuit of electronic components. Wiring to this is typically done with the green conductor with yellow stripe using the same gauge wire as that used for the mains. The pin on the drive at J1-3 is longer than the other pins on J1 giving it a first-make, last-break action so that the drive chassis is never ungrounded when the mains power is connected. This wire is a 'bonding' conductor that should connect to an earthed ground point and must not pass through any circuit interrupting devices.

All of the circuits on J1, J2, and J3 are mains-connected and must never be grounded. The ground terminals at J1-3, J2-1, and J3-5 all connect to the drive chassis and are isolated from all drive internal circuits.

Signal grounding references the drive control circuits to those of the control system. These controls circuits typically have their own earth connection at some point. To eliminate ground-loops it is recommended that the drive signal ground be connected to the control system circuit ground. When this is done the drive signal voltages will be referenced to the same 0 V level as the circuits in the control system. Small currents flow between controller and drive when inputs and outputs interact. The signal ground is the path for these currents to return to their power sources in both controller and drive.

Shields on cables reduce emissions from the drive for CE compliance and protect internal circuits from interference due to external sources of electrical noise. Because of their smaller wire gauge, these should not be used as part of a safety-ground system. Motor cases can be safety-grounded either at the motor, by earthing the frame, or by a grounding conductor in the motor cable that connects to J2-1. This cable should be of the same gauge as the other motor phase cables.

For CE compliance and operator safety, the drive should be earthed by using external tooth lockwashers under the mounting screws. These will make contact with the aluminum chassis through the anodized finish to connect the chassis to the equipment frame ground.

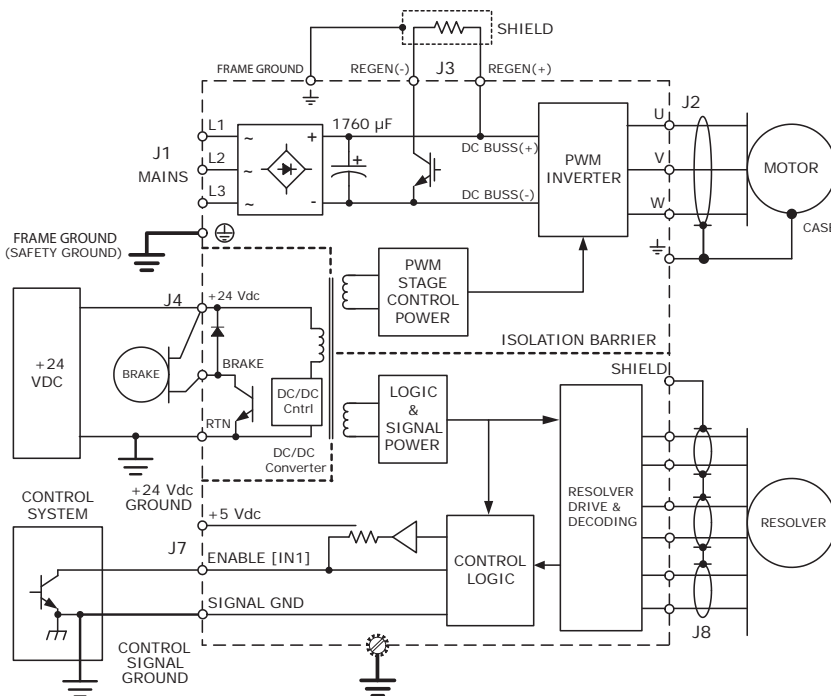

## REGENERATION

The chart below shows the energy absorption in W·s for a Xenus drive operating at some typical mains voltages. When the load mechanical energy is greater than these values an external regen resistor is available as an accessory.

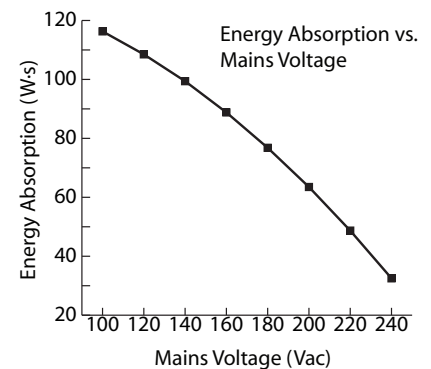

## GROUNDING & SHIELDING FOR CE

Grounding and shielding are the means of controlling the emission of radio frequency energy from the drive so that it does not interfere with other electronic equipment. The use of shielded cables to connect the drive to motors and feedback devices is a way of extending the chassis of the drive out to these devices so that the conductors carrying noise generated by the drive are completely enclosed by a conductive shield.

The process begins at the mains connector of the drive, J1. The ground terminal here has a circle around it indicating that this is the safety or "bonding" ground connection. This should be connected with wire that is the same gauge as that used for the mains. In the case of a short-circuit in the drive the function of this ground connection is to carry the fault current to earth ground until the safety device (fuse or circuit breakers) disconnects the drive from the mains. This connection ensures that the heatplate of the drive remains at earth potential and eliminating a shock hazard that could occur if the chassis were allowed to float to the potential of the mains.

While this connection keeps the heatplate at earth potential the high frequency noise generated by switching circuits in the drive can radiate from the wire used for the safety ground connection. In order to keep the path between the heatplate and earth as short as possible it's also recommended to mount the drive to the equipment panel using external-toothed lock washers. These will penetrate the anodized finish of the heatplate (which is an electrical insulator) and make good electrical contact with the aluminum plate. Grounding the heatplate in this way shortens the path from drive to earth ground and further reduces emissions.

The heatplate also connects directly to the frame ground terminals on the motor, feedback, and regen connectors. Note that the ground symbols for these do not have a circle around them which indicates that these are for shielding and not for safety grounding. Motors and their feedback devices (which are typically in the motor case) should be grounded by mounting to equipment that is grounded as a safety ground. By connecting the shields for these devices at the drive and at the device, the connection is continuous and provides a return path for radio-frequency energy to the drive.

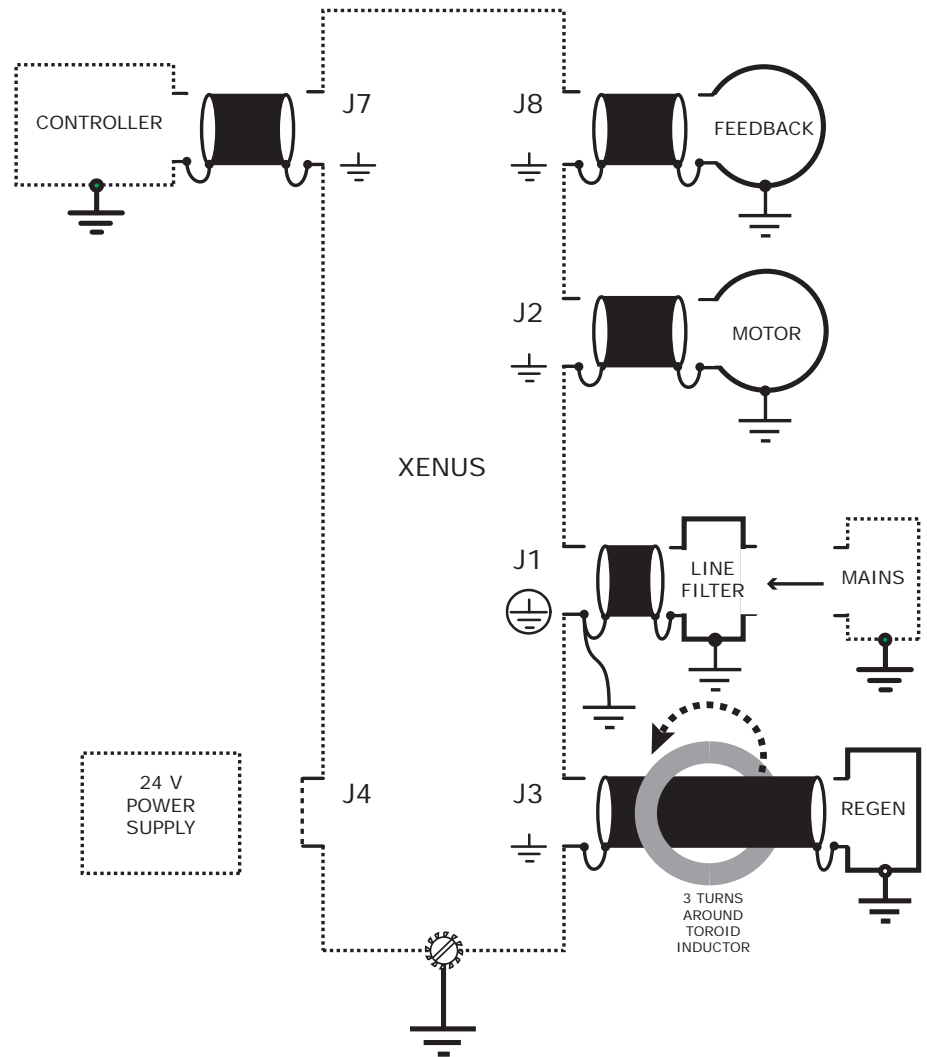

### Notes:

- 1) Shielded cables required for CE are shown in the diagram above.
- 2) Line filter required for CE
- 3) Ferrite core required for shielded cable to regen resistor which must be in shielded enclosure.



**WARNING: Hazardous voltages exist on connections to J1, J2, & J3 when power is applied, and for up to 30 seconds after power is removed.**



**J1 CABLE CONNECTOR:**

Wago: 51118287 or 721-204/026-045/RN01-0000  
Euro-style 7,5 mm pluggable female terminal block with preceding ground receptacle  
Cable: AWG 12, 600 V recommended for XTL-230-36-R and XTL-230-40-R models, AWG 14, 600V for XTL-230-18-R  
Shielded cable required for CE compliance

**J1 MAINS CONNECTIONS**

Signal	Pin
Mains Input L3	4
Protective Ground	3
Mains Input L2	2
Mains Input L1	1

**J2 CABLE CONNECTOR:**

Wago: 51118008 or 721-104/026-047/RN01-0000  
Euro-style 5,0 mm pluggable female terminal block  
Cable: AWG 12, 600 V recommended for XTL-230-36-R and XTL-230-40-R models, AWG 14, 600V for XTL-230-18-R  
Shielded cable required for CE compliance

**J2 MOTOR OUTPUTS**

Signal	Pin
Motor Phase U	4
Motor Phase V	3
Motor Phase W	2
Cable Shield	1

**J3 CABLE CONNECTOR:**

Wago: 51111279 or 721-605/000-044/RN01-0000  
Euro-style 5,0 mm pluggable male terminal block  
Cable: AWG 12, 600 V recommended for XTL-230-36-R and XTL-230-40-R models, AWG 14, 600V for XTL-230-18-R  
Shielded cable required for CE compliance

**J3 REGEN RESISTOR**

Signal	Pin
Regen Resistor	1
No Connection	2
Regen Resistor	3
No Connection	4
Cable Shield	5

**WIRE INSERTION/EXTRACTION TOOL:**

Used on J1, J2, J3, & J4  
Wago 231-131

ISOLATED CIRCUIT

**NOTE: AN EXTERNAL +24 VDC POWER SUPPLY IS REQUIRED FOR OPERATION**

**J4 CABLE CONNECTOR:**

Wago: 51117974 or 721-103/026-047/RN01-0000  
Euro-style 5,0 mm pluggable terminal block

**J4 +24 VDC & BRAKE**

Signal	Pin
+24 Vdc Control Power	3
Brake Output [OUT4]	2
0V (+24 Vdc Return)	1

ISOLATED CIRCUIT

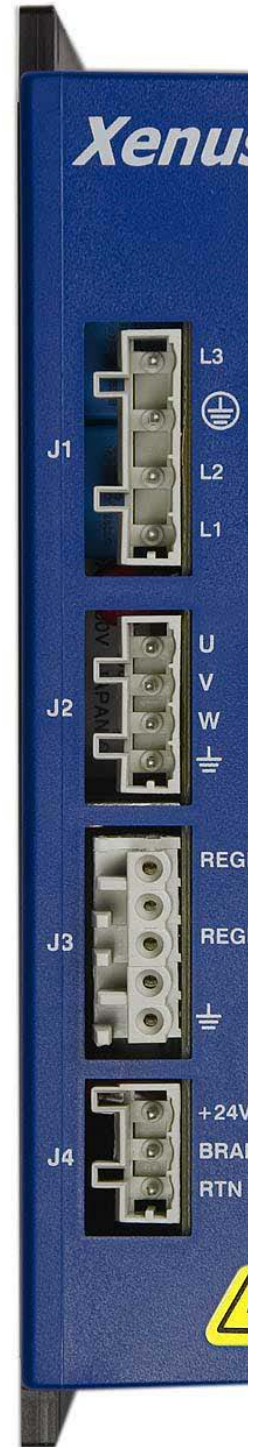



### J5 RS-232 (DTE)

Pin	Signal
6	No connect
5	TxD Output
4	Ground
3	Ground
2	RxD Input
1	No connect

### J5 CABLE CONNECTOR:

RJ-11 style, male, 6 position  
Cable: 6-conductor modular type

#### Notes:

1. CAN circuits are opto-isolated from drive circuits.
2. CAN\_GND connects to drive Signal Ground.
3. CAN\_SHLD and CAN\_V+ are wired-thru on both J6 connectors and have no connection to the drive.

### J6 CAN BUS

Pin	Signal
1	CAN_H
2	CAN_L
3	CAN_GND
4	No connection
5	No connection
6	(CAN_SHLD)
7	CAN_GND
8	(CAN_V+)

#### ISOLATED CIRCUIT

### J6 CABLE CONNECTOR:

RJ-45 style, male, 8 position  
Cable: 8-conductor modular type

### J8 MOTOR FEEDBACK

PIN	SIGNAL	PIN	SIGNAL	PIN	SIGNAL
1	Frame Gnd	6	Hall V	11	Encoder /B
2	+5 Vdc (Note 1)	7	Encoder /X	12	Encoder B
3	Hall U	8	Encoder X	13	Encoder /A
4	+5 Vdc (Note 1)	9	Hall W	14	Encoder A
5	Signal Gnd	10	[IN5] Motemp	15	Signal Gnd

### J8 CABLE CONNECTOR:

High-Density D-Sub, 15 Position, Male

### J7 CONTROL SIGNALS

PIN	SIGNAL	PIN	SIGNAL	PIN	SIGNAL
1	Frame Gnd	10	[IN6] HS	19	Signal Gnd
2	Ref(-)	11	[IN7] HS	20	+5 Vdc (Note 1)
3	Ref(+)	12	[IN8] HS	21	Multi Encoder /X
4	[IN1] Enable	13	[IN9] HS	22	Multi Encoder X
5	[IN2] GP	14	[IN10] HS	23	Multi Encoder /B
6	[IN3] GP	15	Signal Gnd	24	Multi Encoder B
7	[IN4] GP	16	[OUT1]	25	Multi Encoder /A
8	[IN11] GP	17	[OUT2]	26	Multi Encoder A
9	[IN12] GP	18	[OUT3]		

### J7 CABLE CONNECTOR:

High-Density D-Sub, 26 Position, Male

#### NOTES:

1. The total current drawn from the +5 Vdc outputs cannot exceed 400 mA



**WARNING: Hazardous voltages exist on connections to J1, J2, & J3 when power is applied, and for up to 30 seconds after power is removed.**



**J1 CABLE CONNECTOR:**

Wago: 51118287 or 721-204/026-045/RN01-0000  
Euro-style 7,5 mm pluggable female terminal block with preceding ground receptacle  
Cable: AWG 12, 600 V recommended for XTL-230-36-R and XTL-230-40-R models, AWG 14, 600V for XTL-230-18-R  
Shielded cable required for CE compliance

**J1 MAINS CONNECTIONS**

Signal	Pin
Mains Input L3	4
Protective Ground	3
Mains Input L2	2
Mains Input L1	1

**J2 CABLE CONNECTOR:**

Wago: 51118008 or 721-104/026-047/RN01-0000  
Euro-style 5,0 mm pluggable female terminal block  
Cable: AWG 12, 600 V recommended for XTL-230-36-R and XTL-230-40-R models, AWG 14, 600V for XTL-230-18-R  
Shielded cable required for CE compliance

**J2 MOTOR OUTPUTS**

Signal	Pin
Motor Phase U	4
Motor Phase V	3
Motor Phase W	2
Cable Shield	1

**J3 CABLE CONNECTOR:**

Wago: 51111279 or 721-605/000-043/RN01-0000  
Euro-style 5,0 mm pluggable male terminal block  
Cable: AWG 12, 600 V recommended for XTL-230-36-R and XTL-230-40-R models, AWG 14, 600V for XTL-230-18-R  
Shielded cable required for CE compliance

**J3 REGEN RESISTOR**

Signal	Pin
Regen Resistor	1
No Connection	2
Regen Resistor	3
No Connection	4
Cable Shield	5

**WIRE INSERTION/EXTRACTION TOOL:**

Used on J1, J2, J3, & J4  
Wago 231-131

ISOLATED CIRCUIT

**NOTE: AN EXTERNAL +24 VDC POWER SUPPLY IS REQUIRED FOR OPERATION**

**J4 CABLE CONNECTOR:**

Wago: 51117974 or 721-103/026-047/RN01-0000  
Euro-style 5,0 mm pluggable terminal block

**J4 +24 VDC & BRAKE**

Signal	Pin
+24 Vdc Control Power	3
Brake Output [OUT4]	2
0V (+24 Vdc Return)	1

ISOLATED CIRCUIT



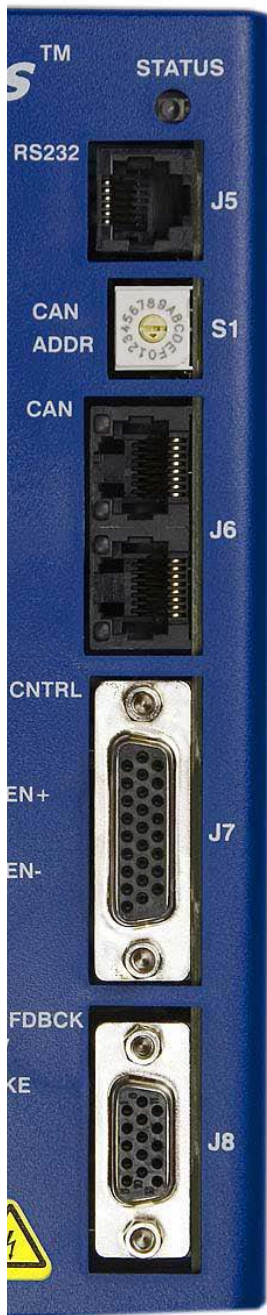

### J5 RS-232 (DTE)

Pin	Signal
6	No connect
5	TxD Output
4	Ground
3	Ground
2	RxD Input
1	No connect

### J5 CABLE CONNECTOR:

RJ-11 style, male, 6 position  
Cable: 6-conductor modular type

#### Notes:

1. CAN circuits are opto-isolated from drive circuits.
2. CAN\_GND connects to drive Signal Ground.
3. CAN\_SHLD and CAN\_V+ are wired-thru on both J6 connectors and have no connection to the drive.

### J7 CONTROL SIGNALS

PIN	SIGNAL	PIN	SIGNAL	PIN	SIGNAL
1	Frame Gnd	10	[IN6] HS	19	Signal Gnd
2	Ref(-)	11	[IN7] HS	20	+5 Vdc (Note 1)
3	Ref(+)	12	[IN8] HS	21	Multi Encoder /X
4	[IN1] Enable	13	[IN9] HS	22	Multi Encoder X
5	[IN2] GP	14	[IN10] HS	23	Multi Encoder /B
6	[IN3] GP	15	Signal Gnd	24	Multi Encoder B
7	[IN4] GP	16	[OUT1]	25	Multi Encoder /A
8	[IN11] GP	17	[OUT2]	26	Multi Encoder A
9	[IN12] GP	18	[OUT3]		

### J7 CABLE CONNECTOR:

High-Density D-Sub, 26 Position, Male

### J6 CAN BUS

Pin	Signal
1	CAN_H
2	CAN_L
3	CAN_GND
4	No connection
5	No connection
6	(CAN_SHLD)
7	CAN_GND
8	(CAN_V+)

### ISOLATED CIRCUIT

### J6 CABLE CONNECTOR:

RJ-45 style, male, 8 position  
Cable: 8-conductor modular type

### J8 MOTOR FEEDBACK

PIN	SIGNAL	PIN	SIGNAL	PIN	SIGNAL
1	Frame Gnd	6	Hall V	11	Encoder Cos(-)
2	+5 Vdc (Note 1)	7	Encoder /X	12	Encoder Cos(+)
3	Hall U	8	Encoder X	13	Encoder Sin(-)
4	+5 Vdc (Note 1)	9	Hall W	14	Encoder Sin(+)
5	Signal Gnd	10	[IN5] Motemp	15	Signal Gnd

### J8 CABLE CONNECTOR:

High-Density D-Sub, 15 Position, Male

### NOTES:

1. The total current drawn from the +5 Vdc outputs cannot exceed 400 mA



**WARNING: Hazardous voltages exist on connections to J1, J2, & J3 when power is applied, and for up to 30 seconds after power is removed.**



**J1 CABLE CONNECTOR:**

Wago: 51118287 or 721-204/026-045/RN01-0000  
Euro-style 7,5 mm pluggable female terminal block with preceding ground receptacle  
Cable: AWG 12, 600 V recommended for XTL-230-36-R and XTL-230-40-R models, AWG 14, 600V for XTL-230-18-R  
Shielded cable required for CE compliance

**J1 MAINS CONNECTIONS**

Signal	Pin
Mains Input L3	4
Protective Ground	3
Mains Input L2	2
Mains Input L1	1

**J2 CABLE CONNECTOR:**

Wago: 51118008 or 721-104/026-047/RN01-0000  
Euro-style 5,0 mm pluggable female terminal block  
Cable: AWG 12, 600 V recommended for XTL-230-36-R and XTL-230-40-R models, AWG 14, 600V for XTL-230-18-R  
Shielded cable required for CE compliance

**J2 MOTOR OUTPUTS**

Signal	Pin
Motor Phase U	4
Motor Phase V	3
Motor Phase W	2
Cable Shield	1

**J3 CABLE CONNECTOR:**

Wago: 51111279 or 721-605/000-043/RN01-0000  
Euro-style 5,0 mm pluggable male terminal block  
Cable: AWG 12, 600 V recommended for XTL-230-36-R and XTL-230-40-R models, AWG 14, 600V for XTL-230-18-R  
Shielded cable required for CE compliance

**J3 REGEN RESISTOR**

Signal	Pin
Regen Resistor	1
No Connection	2
Regen Resistor	3
No Connection	4
Cable Shield	5

**WIRE INSERTION/EXTRACTION TOOL:**

Used on J1, J2, J3, & J4  
Wago 231-131

ISOLATED CIRCUIT

**NOTE: AN EXTERNAL +24 VDC POWER SUPPLY IS REQUIRED FOR OPERATION**

**J4 CABLE CONNECTOR:**

Wago: 51117974 or 721-103/026-047/RN01-0000  
Euro-style 5,0 mm pluggable terminal block

**J4 +24 VDC & BRAKE**

Signal	Pin
+24 Vdc Control Power	3
Brake Output [OUT4]	2
0V (+24 Vdc Return)	1

ISOLATED CIRCUIT



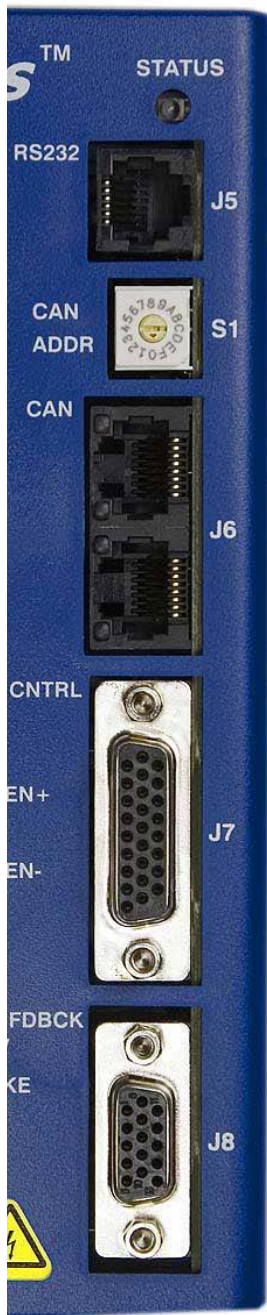

### J5 RS-232 (DTE)

Pin	Signal
6	No connect
5	TxD Output
4	Ground
3	Ground
2	RxD Input
1	No connect

### J5 CABLE CONNECTOR:

RJ-11 style, male, 6 position  
Cable: 6-conductor modular type

#### Notes:

1. CAN circuits are opto-isolated from drive circuits.
2. CAN\_GND connects to drive Signal Ground.
3. CAN\_SHLD and CAN\_V+ are wired-thru on both J6 connectors and have no connection to the drive.

### J7 CONTROL SIGNALS

#### J6 CAN BUS

Pin	Signal
1	CAN_H
2	CAN_L
3	CAN_GND
4	No connection
5	No connection
6	(CAN_SHLD)
7	CAN_GND
8	(CAN_V+)

ISOLATED CIRCUIT

#### J6 CABLE CONNECTOR:

RJ-45 style, male, 8 position  
Cable: 8-conductor modular type

PIN	SIGNAL	PIN	SIGNAL	PIN	SIGNAL
1	Frame Gnd	10	[IN6] HS	19	Signal Gnd
2	Ref(-)	11	[IN7] HS	20	+5 Vdc (Note 1)
3	Ref(+)	12	[IN8] HS	21	Multi Encoder /X
4	[IN1] Enable	13	[IN9] HS	22	Multi Encoder X
5	[IN2] GP	14	[IN10] HS	23	Multi Encoder /B
6	[IN3] GP	15	Signal Gnd	24	Multi Encoder B
7	[IN4] GP	16	[OUT1]	25	Multi Encoder /A
8	[IN11] GP	17	[OUT2]	26	Multi Encoder A
9	[IN12] GP	18	[OUT3]		

#### J7 CABLE CONNECTOR:

High-Density D-Sub, 26 Position, Male

### J8 MOTOR FEEDBACK

PIN	SIGNAL	PIN	SIGNAL	PIN	SIGNAL
1	Frame Gnd	6	Frame Gnd	11	Frame Gnd
2	Ref(-) Output R2	7	Sin(-) Input S1	12	Cos(-) Input S4
3	Ref(+) Output R1	8	Sin(+) Input S3	13	Cos(+) input S2
4	N.C.	9	N.C.	14	N.C.
5	Signal Gnd	10	[IN5] Motemp	15	Signal Gnd

#### J8 CABLE CONNECTOR:

High-Density D-Sub, 15 Position, Male

#### NOTES:

1. The total current drawn from the +5 Vdc output cannot exceed 400 mA

## SINGLE-DRIVE SETUP FOR CANOPEN POSITION CONTROL

Xenus operates as a CAN node. All commands are passed on the CAN bus. CME 2 is used for setup and configuration before installation as CAN node.

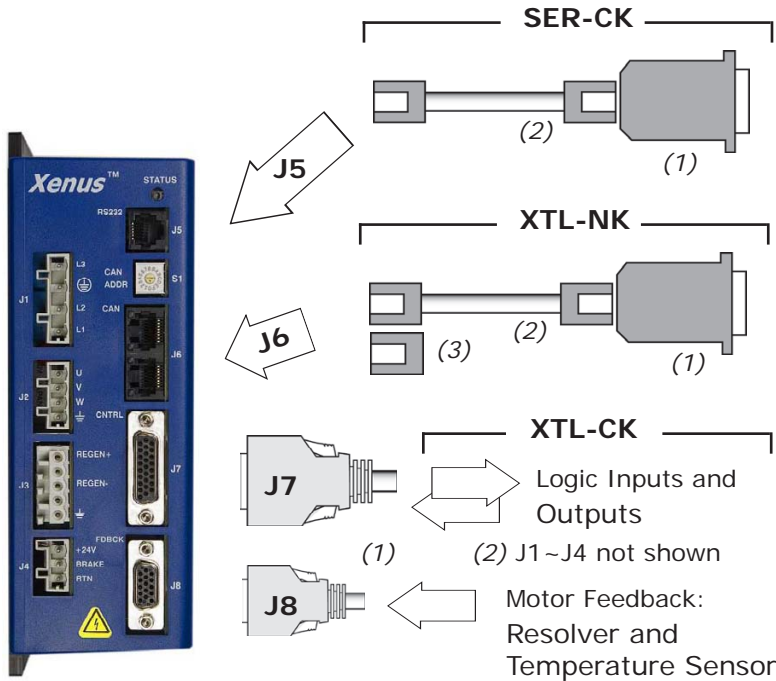



**COM1  
COM2  
COMx**



**CAN  
CARD**

Computer:  
PC or compatible with  
166MHz with 64MB RAM minimum  
266 MHz with 128MB RAM recommended  
Serial port (RS-232)  
CAN bus interface  
Using the minimum requirements will allow CME 2 to run but the performance will be significantly reduced.

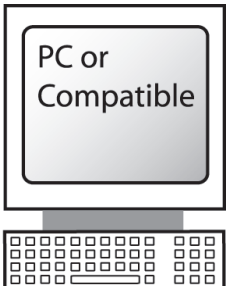

**PC or  
Compatible**



**CML C++ Libraries**  
Windows™ 98, 2000, ME, NT, and Linux



**CMO Copley Motion  
Objects**  
Windows™ 98, 2000, ME, NT, and Linux



**CME 2**  
Windows® 98, 2000, ME, and NT

### Serial Cable Kit SER-CK

Connects a PC serial port to Xenus RX-232 connector J5  
(1) RS-232 9-pin D-Sub to RJ-11 adapter  
(2) 6 ft (2 m) RJ-11 cable

### CANopen Network Kit XTL-NK

Connects a CAN card to Xenus connector J6 and includes terminator for 'last' drive on CAN bus  
(1) CAN card 9-pin D-Sub to RJ-45 adapter  
(2) 6 ft (2 m) RJ-45 cable  
(3) CAN terminator

### Connector/Cable Kit XTL-CK

Includes connectors for J1~J4, J7, J8:  
(1) Soldercup connectors for J7 & J8  
(2) Wago connectors for J1~J4

See diagram on page 10 for connections to:

- J1 AC mains power
- J2 Motor phases
- J3 Regen resistor
- J4 +24 Vdc Aux Power

### Ordering Guide

Table below shows parts to order for the configuration on this page  
See page 19 for other parts required (motor, +24 Vdc power supply, etc.) .

PART NUMBER	DESCRIPTION
XTL-230-18	Xenus XTL Servodrive 6/18 A
XTL-230-36	Xenus XTL Servodrive 12/36 A
XTL-230-40	Xenus XTL Servodrive 20/40 A
XTL-NK	CANopen Network Kit
XTL-CK	Xenus Solder-Cup Connector Kit
CME2	CME 2 Configuration Software CD
SER-CK	CME 2 RS-232 Cable Kit

Add -S to part numbers above for sin/cos feedback, or add -R for resolver feedback models.

## MULTIPLE-DRIVE SETUP FOR CANOPEN POSITION CONTROL

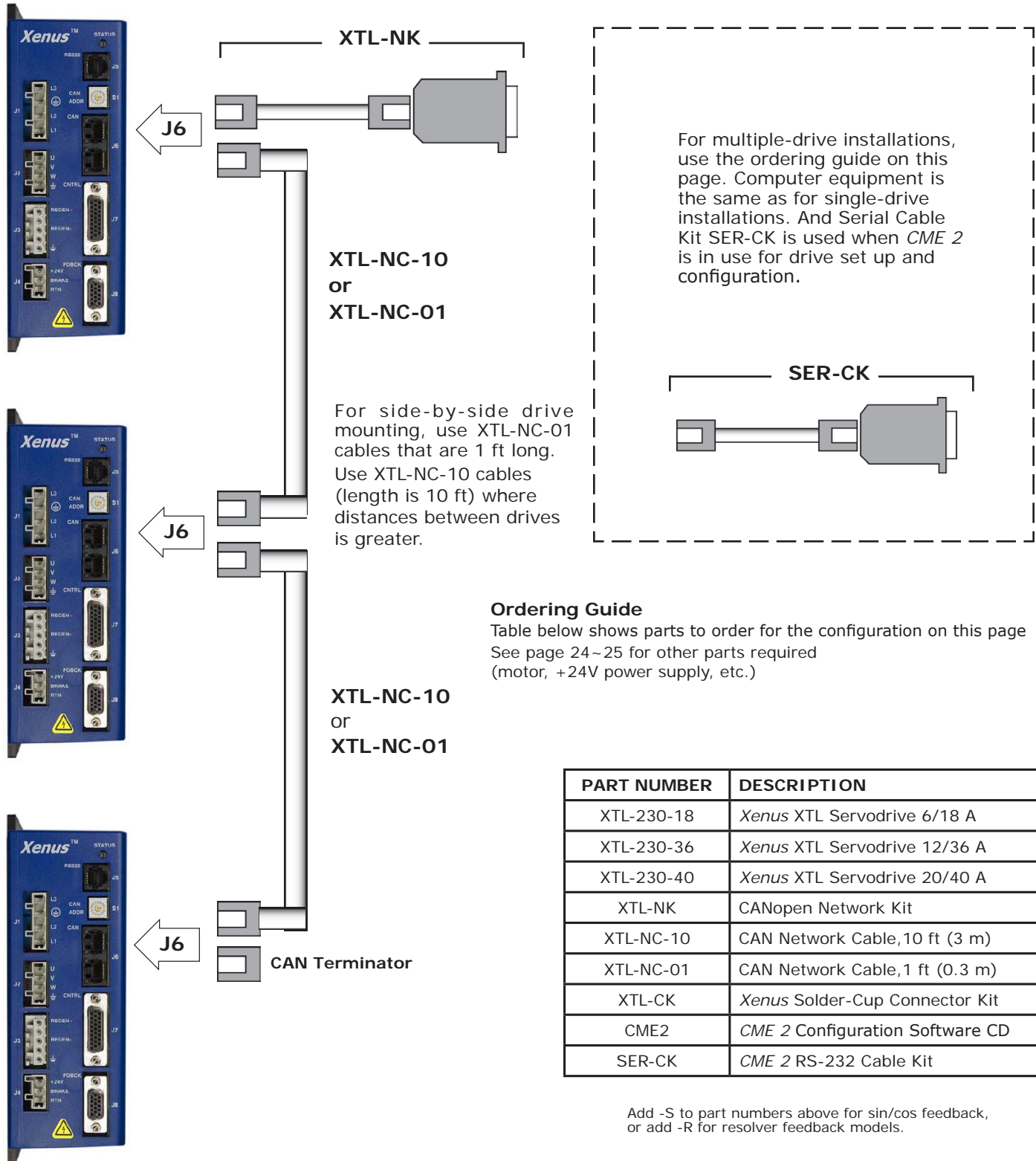

## STAND-ALONE OPERATION

Xenus takes digital position commands in Pulse/Direction, or CW/CCW format from an external controller or quadrature encoder signals from a master-encoder for electronic gearing. Velocity or torque control can be from  $\pm 10V$ , digital PWM signals.  
CME 2 used for setup and configuration.

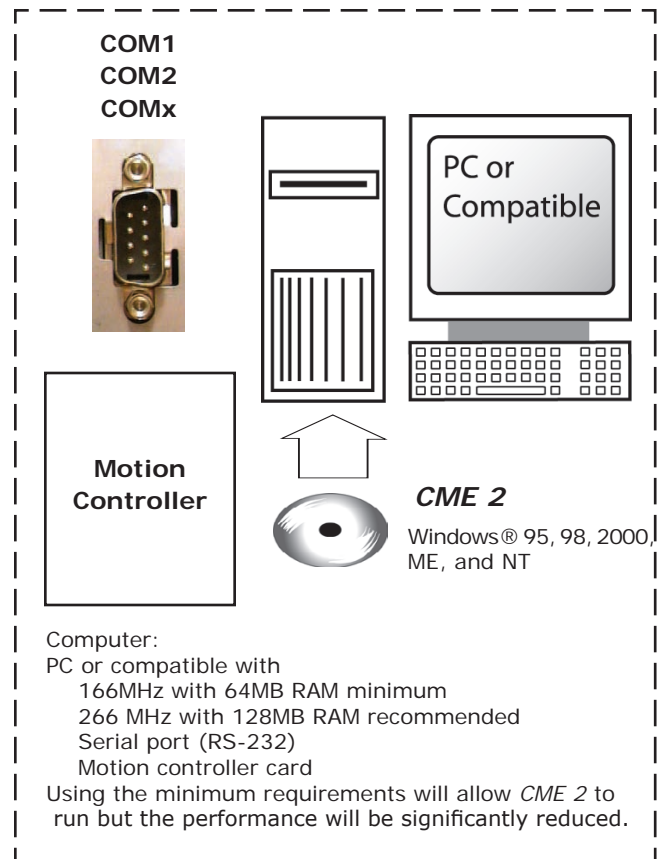
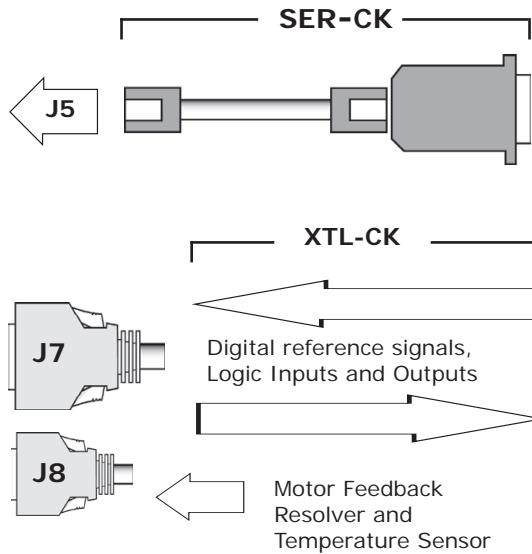

### ORDERING GUIDE

This table shows parts to order for the configuration on this page  
See page 24~25 for other parts required (motor, +24 Vdc power supply, etc.)

PART NUMBER	DESCRIPTION
XTL-230-18	Xenus XTL Servodrive 6/18 A
XTL-230-36	Xenus XTL Servodrive 12/36 A
XTL-230-40	Xenus XTL Servodrive 20/40 A
XTL-CK	Xenus Solder-Cup Connector Kit
CME2	CME 2 Configuration Software CD
SER-CK	CME 2 RS-232 Cable Kit

Add -S to part numbers above for sin/cos feedback, or add -R for resolver feedback models.

INSTALLATION

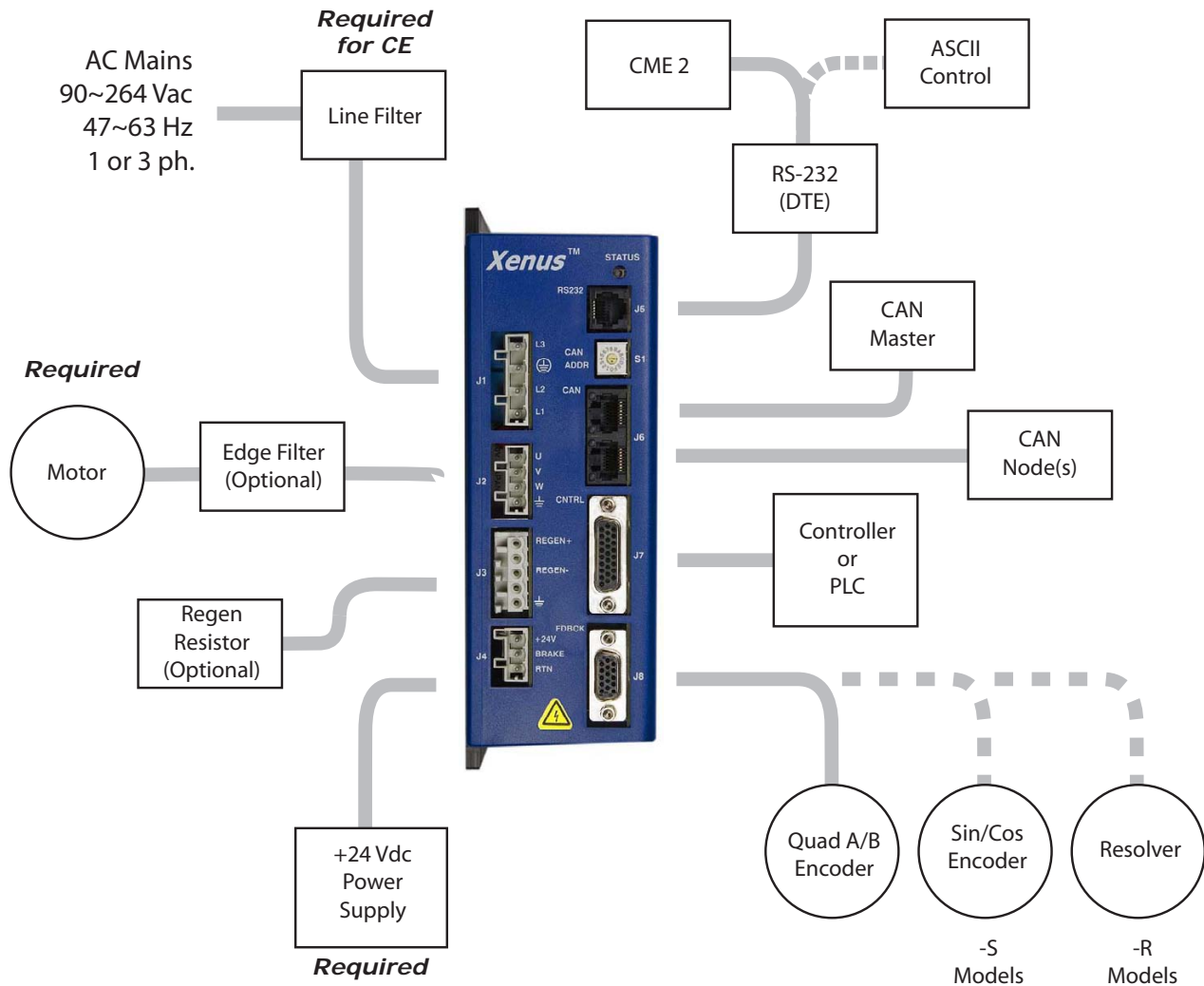

## HEATSINK & FAN CONFIGURATIONS

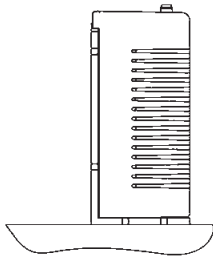

**NO HEATSINK  
NO FAN**



**NO HEATSINK  
WITH FAN**

*NOTE: FANS ARE NOT INCLUDED  
WITH HEATSINKS OR HEATSINK  
KITS*

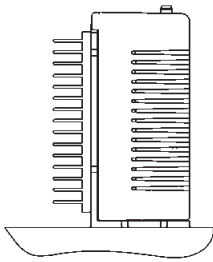

**LOW-PROFILE  
HEATSINK  
NO FAN**



**LOW PROFILE HEATSINK  
WITH FAN**

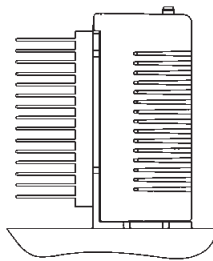

**STANDARD HEAT-  
SINK  
NO FAN**

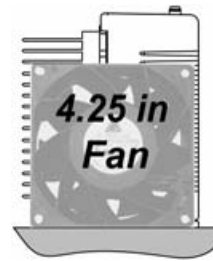

**STANDARD HEATSINK  
WITH FAN**

### HEATSINK MOUNTING

A dry-film interface pad is used in place of thermal grease. The pad is die-cut to shape and has holes for the heat sink mounting screws. There are two protective sheets, blue on one side and clear on the other. Both must be removed when the interface pad is installed.

### STEPS TO INSTALL

1. Remove the blue protective sheet from one side of the pad and place the pad on the drive. Make sure that the holes in the pad align with the holes on the drive.
2. Remove the clear protective sheet from the pad.
3. Mount the heatsink onto the drive taking care to see that the holes in the heatsink, pad, and drive all line up.
4. Torque the #6-32 mounting screws to 8–10 lb-in (0.9–1.13 N·m).

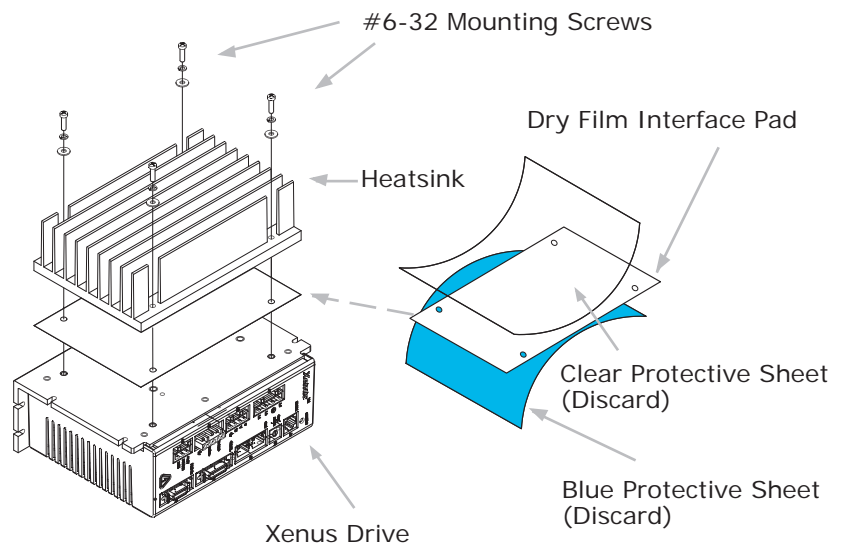

## MAXIMUM OPERATING TEMPERATURE VS HEATSINK TYPE & AIR CIRCULATION

The charts below show that maximum ambient temperature vs. continuous output current for the Xenus models. The cooling options are no heatsink, standard heatsink, and low-profile heatsink. For each of these the drive can be operated with convection or forced-air cooling.

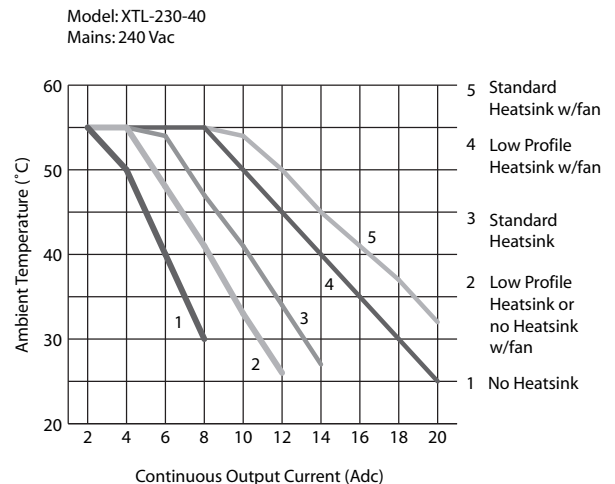
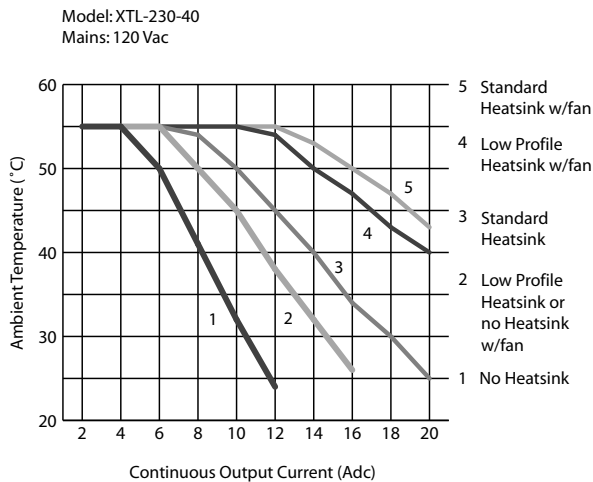
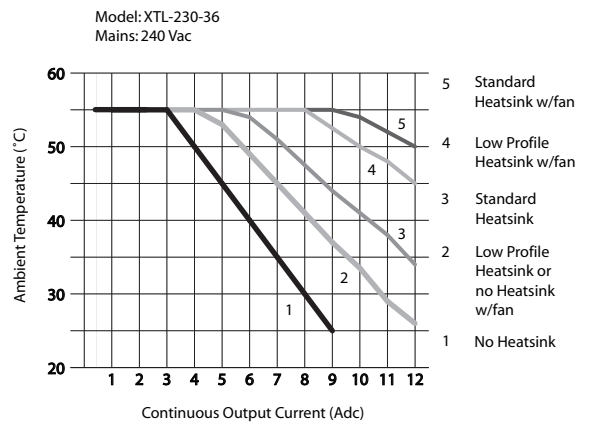
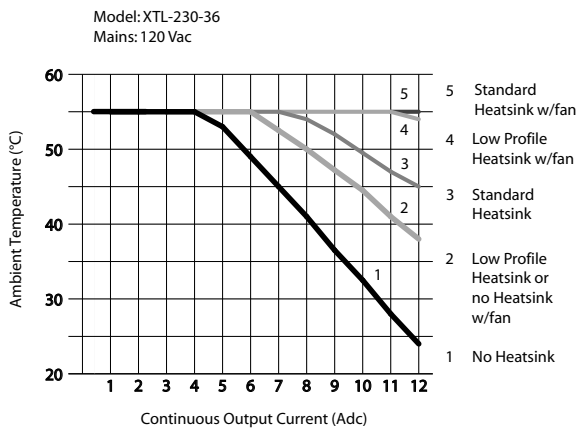
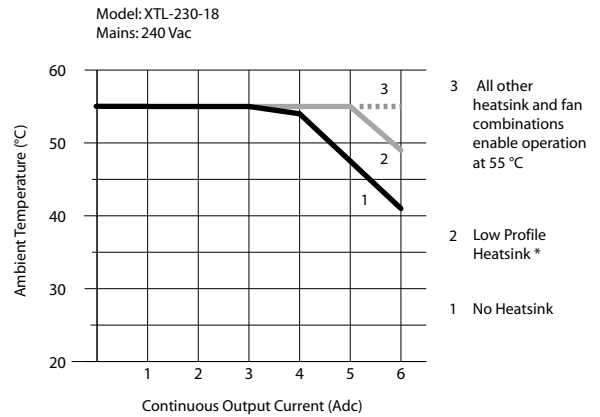
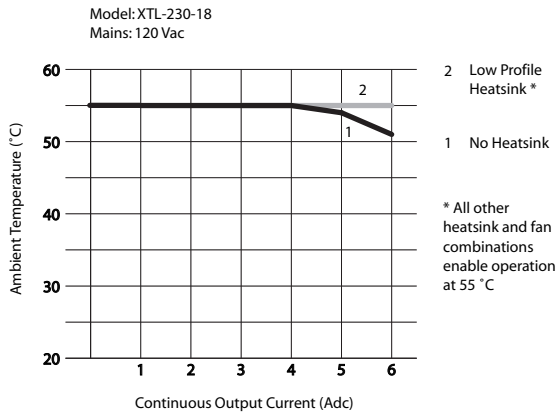

**ORDERING GUIDE** Add -S to part numbers above for sin/cos feedback or add -R for resolver feedback models.

XTL-230-18	Xenus XTL Servo Drive 6/18 Adc
XTL-230-36	Xenus XTL Servo Drive 12/36 Adc
XTL-230-40	Xenus XTL Servo Drive 20/40 Adc

**ACCESSORIES**

	QTY	REF	DESCRIPTION	MANUFACTURERS PART NUMBER
XTL-CK Connector Kit with Solder Cup Connectors for J7 & J8	1	J1	Plug, 4 position, 7.5 mm, female	Wago: 51118287 or 721-204/026-045/RN01-0000
	1	J2	Plug, 4 position, 5.0 mm, female	Wago: 51118008 or 721-104/026-047/RN01-0000
	1	J3	Plug, 5 position, 5.0 mm, male	Wago: 51111279 or 721-605/000-044/RN01-0000
	1	J4	Plug, 3 position, 5.0 mm, female	Wago: 51117974 or 721-103/026-047/RN01-0000
	4	J1~4	Tool, wire insertion & extraction (for J1~4)	Wago: 231-131
	1	J7	Connector, 26 position, solder-cup	High Density D-Sub Male, 26 position connector
	1		Back shell, for 26 position connector	Backshell for above
	1	J8	Connector, 15 position, solder cup	High Density D-Sub Male, 15 position connector
	1		Back shell, for 15 position connector	Backshell for above
CME 2	J5		CME 2 Drive Configuration Software (CD-ROM)	
SER-CK	J5		RS-232 Cable Kit	

Connectors & Software for CANopen Operation

XTL-NK	1	J6	D-Sub 9F to RJ-45 Adapter	
	1		CAN bus RJ-45 terminator	
	1		CAN bus network cable, 10 ft (3 m)	
XTL-CV	1		D-Sub 9F to RJ-45 Adapter	
XTL-NC-10	1		CAN bus Network Cable, 10 ft (3 m)	
XTL-NC-01	1		CAN bus Network Cable, 1 ft (0.3 m)	
XTL-NT	1	CAN bus Network Terminator		
CMO	CD with CMO Software			
CML	CD with CML Software (Note: license fee required)			

Heatsink Kits for Field Installation (Optional)

XTL-HL Heatsink Kit Low-Profile	1	Heatsink, low-profile	
	1	Heatsink thermal material	
	4	Heatsink hardware	
XTL-HS Heatsink Kit Standard	1	Heatsink, standard	
	1	Heatsink thermal material	
	4	Heatsink hardware	

Regeneration Resistors (Optional)

XTL-RA-03	Regeneration resistor assembly (for XTL-230-18), 30 Ω	
XTL-RA-04	Regeneration resistor assembly (for XTL-230-36 & XTL-230-40 models), 15 Ω	

Edge Filter (Optional)

XTL-FA-01	Edge filter		
Edge Filter Connector Kit XTL-FK	1	Plug, 4 position, 5.0 mm, female	Wago: 51118008 or 721-104/026-047/RN01-0000
	1	Plug, 5 position, 5.0 mm, male	Wago: 51118042 or 721-105/026-047/RN01-0000
	2	Tool, wire insertion & extraction (for J1~4)	Wago: 231-131

Example: Order one Xenus drive, resolver version, 6/18 A with solder-cup connector Kit, CME 2 CD, serial cable kit and small heatsink fitted at the factory:

Qty	Item	Remarks
1	XTL-230-18-R-HS	Xenus servo drive
1	XTL-CK	Connector Kit
1	CME 2	CME 2 CD
1	SER-CK	Serial Cable Kit

Note: The heatsink can be fitted at the factory by adding an "-HS" or "-HL" to the drive part number to specify the standard or low-profile type. For fitting a heatsink to an drive in the field, complete kits are available (XTL-HS and XTL-HL). These kits contain the heatsink, mounting hardware, and dry-film interface.