

## Features

- Reduce Noise
- Integrated into the amplifier
- Effective 176 $\mu$ H of inductance
- Passive / Active filter
- Removes vertical monitor lines

## Abstract

Most noise is capacitively coupled from the motor power cable to neighboring cables, during the transmission of the PWM signal. To reduce noise, twisted shielded cable must be used and cables should not be bundled in the same conduit. Since energy is coupled in accordance to the square root law, separation of cables by a few inches can produce a substantial reduction in cross coupling.

Additionally, using an edge filter can reduce the high frequency component of the PWM signal so less energy will be coupled during transmission.

## Ordering Guide

This filter is designed specifically for the modular series amplifiers. The modular series includes: 5x24AC, 5x24DC, 7x25AC, 7x25DC, 7x26AC, 7x26DC, 7x29AC, and 7x29DC. Append the letter F to the model number, for the filter option. Example 5424ACF



Image of the internal filter, taken out of the 7225ACF

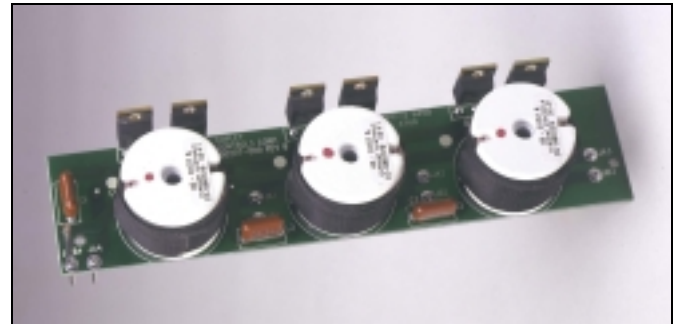

## Description

The edge filter option reduces the rate of change of output voltage by a factor of 10, substantially reducing noise in the system. Copley amplifiers typically have a 200ns-rise time (high frequency component in the Mega Hz range) so, by using the edge filter, the rise time can be increased to a 2 $\mu$ s-rise time, reducing the high frequency component by a factor of 10. The filter is designed with 88 $\mu$ H inductors and a proprietary passive active circuit. The inductance will provide a total of 176 $\mu$ H, in series with the load, helping to reduce ripple current, and brings low inductance motors, into the required range.

## Functional diagram

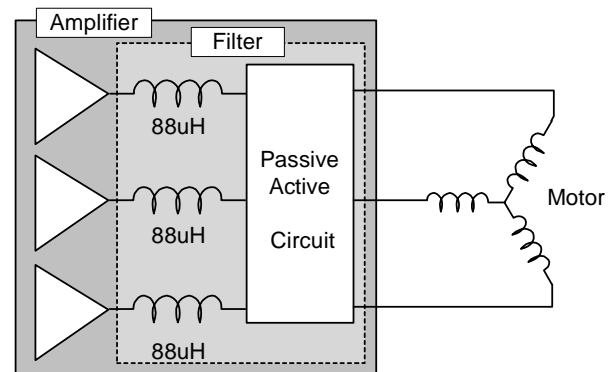

## PWM Output Plot

