



- **Provides Mounting & Connections for Stepnet Module CANopen Stepping Motor Driver**

FEATURES

- **Develop & Debug *Stepnet* projects then transfer design to OEM pc board.**

MODEL	DRIVER	Ic	Ip	VDC
TDK-075-01	STM-075-07	5	7	75

DESCRIPTION

The Development Kit is a companion product to Copley Controls' new *Stepnet Module* stepping motor driver. It provides mechanical mounting and electrical connections for the driver so users can quickly connect *Stepnet* and begin to develop applications.

Euro style screw-terminal connector blocks simplify connections for power and motor phase-windings. Sub-D connectors have compatible pinouts with *Accelus™* and *Accelnet™* panel amplifiers for command, I/O and optional motor encoder signals.

A 16-position rotary switch connects to *Stepnet* I/O pins for selection of the CAN bus device address. Individual toggle switches are wired to other I/O pins to simulate limit switches, motor overtemperature sensor, and home switch functions. Jumpers permit these switches to be disconnected so that the I/O pins can connect to

user equipment through the Sub-D connectors.

A 121Ω resistor can be jumpered in or out as a terminator for the CAN bus signals if the development kit is the last device on a CAN bus.

Four LED's can be jumpered in or out to the *Stepnet* logic outputs. These give an easy read-out of the output status for debugging.

Motor encoder signals are connected through from the motor connector to the signal connector eliminating split cables in cases where the *Stepnet* is operating as a stand-alone servo-motor control. In these cases, the external controller uses the encoder for position feedback, and *Stepnet* operates the stepping motor as a DC brushless motor.

RS-232 CONNECTION

The RS-232 port is used to configure *Stepnet* for stand-alone applications, or for configuration before it is installed into a CANopen network. CME 2™ software communicates with *Stepnet* over this link and is then used for complete amplifier setup. The CAN address that is set by the rotary switch can be monitored, and an address offset programmed as well. This will add to the switch address to produce a working CAN address that can be from 1 to 127.

The RS-232 connector, J4, is a modular type that uses a 6-position plug, four wires of which are used for RS-232. A connector kit is available (SER-CK) that includes the modular cable, and an adaptor to interface this cable with a 9-pin RS-232 port on a computer.

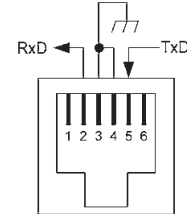

CAN CONNECTORS

Connectors J6 & J7 are Sub-D male and female 9-position types that conform to the CAN DS-102 Physical Layer specification. The male-female configuration supports a single cable type with male and female connectors that can be daisy-chained from device to device along a CANopen network.

Stepnet uses only the CAN_H, CAN_L, and CAN_GND signals. The CAN_GND is connected to the circuit ground on the development kit. This ground is also shared by the amplifier power supply, accessory +5V (for encoders), and the RS-232 link. Other DS-102 signals are wired-through for use by products that might support them.

The table below lists the signals and pins on J6 & J7. Signals in () are those that have no connection on the development kit and which are connected pin-to-pin between J6 & J7.

PIN	SIGNAL
1	(Reserved)
2	CAN_L
3	CAN_GND
4	(Reserved)
5	(CAN_SHLD)
6	CAN_GND
7	CAN_H
8	(Reserved)
9	(CAN_V+)

CAN Bus Connector Signals

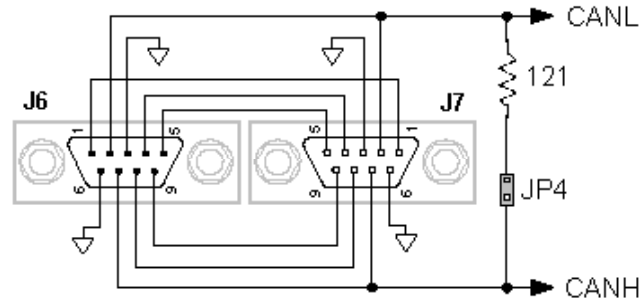

Important!
Install JP4 ONLY if development kit is the LAST node on a CAN bus

CAN ADDRESS SELECTION

Rotary switch SW7, labeled “CAN ADDR” connects to IN7, IN8, IN9, and IN10 of the amplifier. These are programmable inputs which default to CAN address bits. The switch will select CAN addresses 0x01~0x0F (dec 1~15) . Address 0 is reserved for network management devices. The CAN standard permits up to 127 devices, so if the amplifier must have an address beyond 0x0F(dec 15), this is done by programming an address offset into the amplifier before it is installed into a CAN environment or by programming logic inputs as CAN address bits. See the *Stepnet* datasheet for more details on CAN address setup.

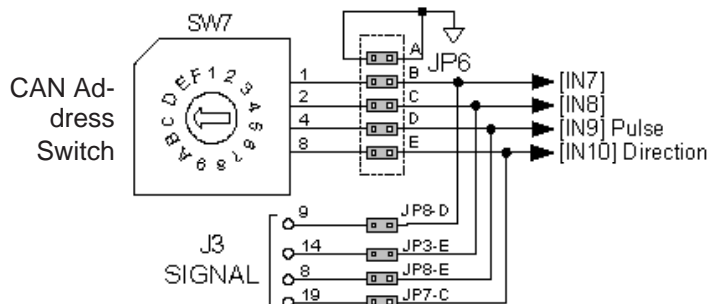

Stepnet Logic Inputs

Note: To use inputs 7,8,9, or 10 as logic inputs remove jumpers on JP6 and insert jumpers on JP3, JP7 & JP8 as shown at left.

Inputs [IN9,10] are digital reference inputs for use when amplifier is used in stand-alone mode.

LOGIC INPUTS

Stepnet has twelve logic inputs. [IN1] is dedicated to the amplifier enable function, the other inputs are programmable. The chart below shows the placement of jumpers to connect logic inputs to switches on the development kit, or to external signals via signal connector J3:

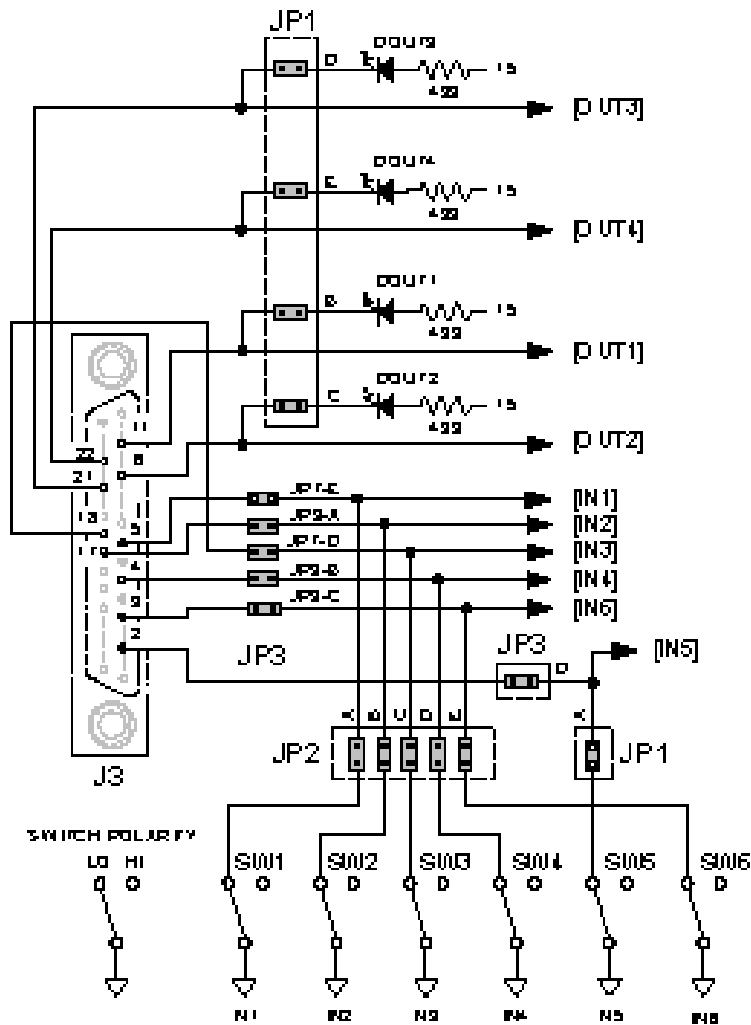

LOGIC OUTPUTS

Stepnet has four logic outputs that can drive controller logic inputs or relays. If relays are driven, then flyback diodes must be connected across their terminals to clamp overvoltages that occur when the inductance of the relay coil is suddenly turned off.

As delivered, these outputs drive four LED's. Jumpers JP1-B,C,D, & E connect these LED's to logic outputs. These are N-channel MOSFET's which sink current from loads connected to positive voltages. When the outputs are ON (Active Low), they ground the cathode of the led's which then turn on as they are connected to the +5Vdc supply via current-limiting resistors.

The logic outputs also connect to signal connector J3. If they are used to drive external loads >+5Vdc, the LED jumpers must be removed.

Logic Input	Default Function	On-Board Connection		External Connection	
		SW	JP	J3	JP
IN01	Enable	SW1	JP2-A	J3-5	JP7-E
IN02	Fwd Enable	SW2	JP2-B	J3-17	JP3-A
IN03	Rev Enable	SW3	JP2-C	J3-18	JP7-D
IN04	Home	SW4	JP2-D	J3-4	JP3-B
IN05	Motemp	SW5	JP1-A	J3-2	JP3-D
				J2-9	JP9-E
IN06	IN6	SW6	JP2-E	J3-3	JP3-C
		ENC X	JP8-B		
IN07	IN7	SW7-1	JP6-B	J3-9	JP8-D
IN08	IN8	SW7-2	JP6-C	J3-14	JP3-E
IN09	Step	SW7-4	JP6-D	J3-8	JP8-E
IN10	Direction	SW7-8	JP6-E	J3-19	JP7-C
IN11	IN11	ENC A	JP8-A	J3-7	JP7-B
IN12	IN12	ENC B	JP8-C	J3-20	JP7-A

ENCODER CONNECTIONS

The development kit has a 26C32A differential line receiver for the motor encoder inputs. Differential-output encoders are preferred for best signal quality and noise rejection. Wiring should be twisted-pairs, preferably with a shield for each pair. To eliminate noise on the encoder signals caused by reflections on the cables, it is good practice to terminate signal-pairs with a resistor that matches the characteristic impedance of the cable. On the development kit, 121Ω resistors are provided for this purpose. Jumpers at JP9-A, B, and C connect these termination resistors across the differential signals when installed.

If single-ended encoders are used, they should be connected to the A, B, and X pins leaving the /A, /B, and /X pins open and jumpers at JP9-A, B, and C should be removed.

POWER SUPPLIES

+HV

Amplifier main power, +HV, is typically supplied by unregulated DC power supplies. These must be isolated from the mains, and all circuits should be grounded to earth at some point.

The +HV supply connects to J1. Pin J1-1 is the +HV positive terminal, and pin J1-2 is the power supply negative terminal that connects to circuit ground. For good wiring practice, the +HV wires should be twisted together for noise suppression, and the power supply should not be grounded. Doing this ensures that the higher currents flowing in these conductors will not flow through any circuit grounds where they might induce noise. During deceleration, mechanical energy in the motor and load is converted back into electrical energy that must be dissipated as the motor comes to a stop. While some of this is converted to heat in the motor windings, the rest of it will flow through the amplifier into the power supply. An external storage capacitor should be used if the load has appreciable inertia, and this should be sized such that adding the undissipated energy from the motor will not raise the voltage beyond the point at which the amplifier shuts down. When this is not

possible, an external 'dumper', or regenerative energy dissipater must be used which acts as a shunt regulator across the +HV and Gnd terminals.

Switching Power Supplies

Switching power supplies can also be used to power *Stepnet*. Unlike unregulated supplies, these cannot accept reverse energy flow, so an isolating diode must be placed between the power supply and J1-1 to block current flow back into the power supply. When this is done, an external storage capacitor must be used across J1-1 & J1-2 because the capacitor on the Development Kit board is only for ripple-current control, and can't store enough energy to handle regeneration.

Grounding

An earthing ground connection can be made via a second conductor to J1-2 that connects to the equipment frame ground.

Encoder +5 Vdc

Encoder power is supplied from an external +5 Vdc supply with sufficient current to drive the motor encoder. Typically these will be 250 mA or less. In cases where an encoder uses a separate interpolator module to process the data, current demand may be higher. Consult the motor encoder literature to be sure that the +5Vdc supply can handle the encoder power requirements.

Aux HV

Not required for stand-alone operation, an Aux HV power supply provides power for the drive control circuits so that CAN bus communications with the drive can be maintained when the +HV supply is turned off. This might occur as a result of an Emergency Off condition, or for machine operator intervention. The Aux HV supply does not power the PWM stage that drives the motor, but keeps the drive controller enabled as well as inputs and outputs. The Aux HV supply must be less than the +HV supply voltage and greater than the drive minimum +HV (> 20 Vdc).

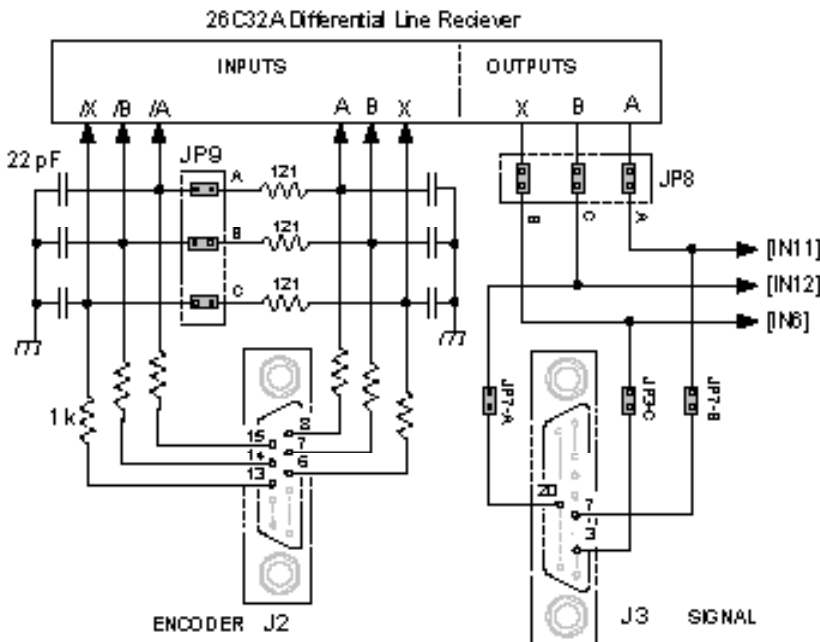

CONNECTOR LAYOUT

CANopen Signal	Pin
(Reserved)	1
CAN_L	2
CAN_GND	3
(Reserved)	4
(CAN_SHLD)	5

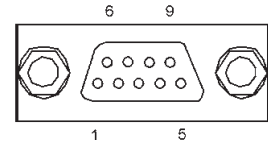

J8 SIGNAL	PIN
+5V Input	1
Gnd	2
Gnd	3
Aux HV	4

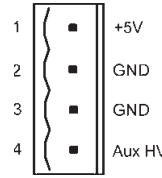

J8

J1 SIGNAL	PIN
+HV Input	1
GND	2
Motor A+ Output	3
Motor A- Output	4
Motor B+ Output	5
Motor B- Output	6

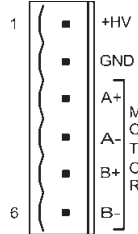

J1

J2

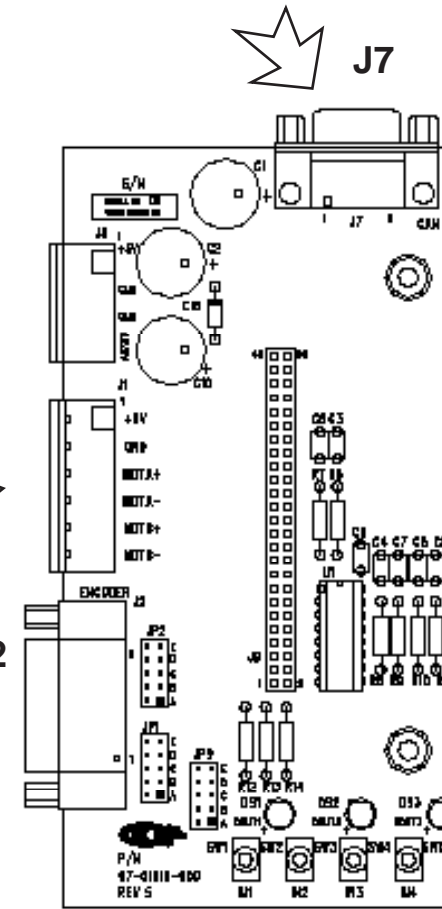

J2 SIGNAL	PIN
Encoder /A Input	15
Encoder /B Input	14
Encoder /X Input	13
Signal Ground	12
+5V Output	11
Signal Ground	10
Motor Temp Sensor [IN5]	9

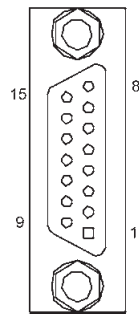

PIN	J2 SIGNAL
8	Encoder A Input
7	Encoder B Input
6	Encoder X Input
5	Signal Ground
4	N.C.
3	N.C.
2	N.C.
1	Chassis Ground

Pin	CANopen Signal
6	CAN_GND
7	CAN_H
8	(Reserved)
9	(CAN_V+)

CANopen Notes:

1. Connector pinouts for J6 & J7 follow CAN standard DS-102.
2. Signals in () are wired-through from J7 to J6 and have no other connections on the pc board.
3. CAN_GND is connected to Gnd on pc board (Stepnet signal and power ground)

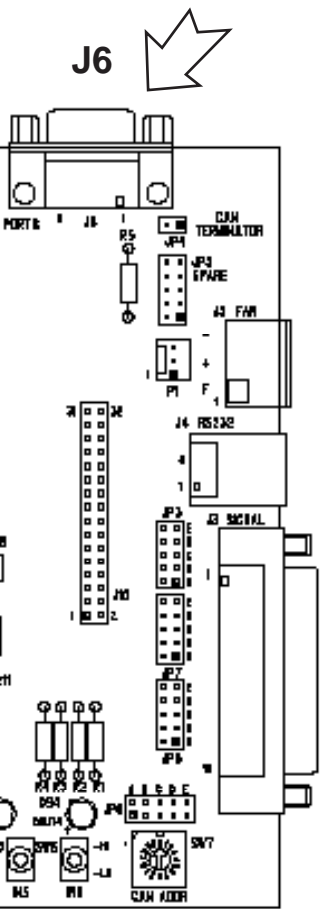
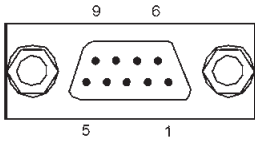

PIN	J5 SIGNAL
1	-
2	+
3	F

PIN	J4 SIGNAL
6	No Connection
5	TxD Output
4	Ground
3	Ground
2	RxD Input
1	No Connection

J3 SIGNAL	PIN
Chassis Ground	1
Motemp [IN5]	2
GP Input [IN6]	3
GP Input [IN4]	4
Enable Input [IN1]	5
Output [OUT2]	6
HS Input [IN11]	7
HS Input [IN9]	8
HS Input [IN7]	9
Signal Ground	10
Output [OUT1]	11
Signal Ground	12
Signal Ground	13

PIN	J3 SIGNAL
14	[IN8] HS Input
15	Signal Ground
16	Signal Ground
17	[IN2] POS Limit Input
18	[IN3] NEG Limit Input
19	[IN10] HS Input
20	[IN12] HS Input
21	[OUT3] Output
22	[OUT4] Output
23	+5 Vdc Output
24	RS-232 TxD Output
25	RS-232 RxD Input

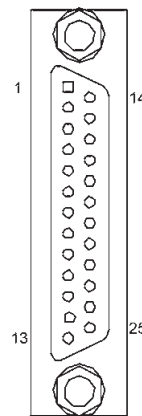

ORDERING GUIDE

PART NUMBER	DESCRIPTION
TDK-075-01	<i>Stepnet</i> [™] Development Kit
TDK-CK	<i>Stepnet</i> [™] Development Kit Connector Kit
SER-CK	Serial Cable Kit
CME2	<i>CME 2</i> [™] Drive Configuration Software CD-ROM