

**CANopen**

### Control Modes

- Indexer, Point-to-Point, PVT
- Camming, Gearing, Position, Velocity, Torque

### Command Interface

- CANopen
- ASCII and discrete I/O
- Stepper commands
- $\pm 10V$  position/velocity/torque command
- PWM velocity/torque command
- Master encoder [Gearing/Camming]

### Communications

- CANopen
- RS232

### Feedback

- Digital Quad A/B encoder
- Secondary encoder for dual position loops
- Analog sin/cos encoder
- Digital Halls

### I/O - Digital

- 12 inputs, 3 outputs

### Dimensions: mm [in]

- 168 x 99 x 31 [6.6 x 3.9 x 1.2]



Model	Ip	Ic	Vdc
ACP-055-18	18	6	55
ACP-090-09	9	3	90
ACP-090-18	18	6	90
ACP-090-36	36	12	90
ACP-180-09	9	3	180
ACP-180-18	18	6	180

## DESCRIPTION

*Accelnet* is a high-performance, DC powered amplifier for position, velocity (using encoder, Halls, or BEMF), and torque control of brushless and brush motors. It can operate as a distributed drive using the CANopen protocol, or as a stand-alone drive accepting analog or digital commands from an external motion controller. In stand-alone mode, current and velocity modes accept digital 50% PWM or PWM/polarity inputs as well as  $\pm 10V$  analog. In position mode inputs can be incremental position commands from step-motor controllers, analog  $\pm 10V$ , or A/B quadrature commands from a master-encoder. Pulse to position ratio is programmable for electronic gearing.

Amplifier commissioning is fast and simple using CME 2™ software operating under Windows® and communicating with *Accelnet* via CAN or an RS-232 link. CAN address selection is by a 16-position rotary switch. If there are more than sixteen devices on the CAN bus, the additional address bits needed can come from programmable inputs, or can be set in flash memory.

*Accelnet* models operate as Motion Control Devices under the DSP-402 protocol of the CANopen DS-301 V4.01 (EN 50325-4) application layer. DSP-402 modes supported include: Profile Position, Profile Velocity, Profile Torque, Interpolated Position Mode (PVT), and Homing. The two CAN ports are optically isolated from amplifier circuits.

There are twelve digital inputs eleven of which have programmable functions. These include CAN address, motion-abort, limit & home switches, stepper/encoder pulse inputs, reset, digital torque or velocity reference, and motor over-temperature. Input [IN1] is dedicated for the amplifier Enable. There are three programmable logic outputs for reporting an amplifier fault, motor brake control, or other status indications.

Amplifier power is transformer-isolated DC from regulated or unregulated power supplies. An AuxHV input powers control circuits for “keep-alive” operation permitting the amplifier power stage to be completely powered down without losing position information, or communications with the control system.

## GENERAL SPECIFICATIONS

Test conditions: Load = Wye connected load: 2 mH + 2 Ω line-line. Ambient temperature = 25°C, +HV = HV<sub>max</sub>

MODEL	ACP-055-18	ACP-090-09	ACP-090-18	ACP-090-36	ACP-180-09	ACP-180-18	
OUTPUT POWER 36 (25.5)							
PEAK CURRENT	18 (12.7)	9 (6.4)	18 (12.7)	18 (12.7)	9 (6.4)	18 (12.7)	
PEAK TIME	1	1	1	1	1	1	ES
CONTINUOUS CURRENT	3 (2.1)	6 (4.2)	12 (8.5)	3 (2.1)	6 (4.2)	12 (8.5)	ES
PEAK OUTPUT POWER	0.79	1.55	2.95	1.59	3.15	3.15	KW
CONTINUOUS " "	0.27	0.53	1.06	0.53	1.06	1.06	WK
OUTPUT RESISTANCE	0.075	0.075	0.036	0.075	0.075	0.075	Ω
MAXIMUM OUTPUT VOLTAGE	VOUT = HV*0.97 - ROUT*IOUT						

INPUT POWER							
HV <sub>min</sub> ~ HV <sub>max</sub>	+20 to +55	+20 to +90	+20 to +90	+20 to +90	+20 to +180	+20 to +180	Vdc, Transformer-isolated
I <sub>peak</sub>	20	10	20	40	10	20	Adc (1 sec) peak
I <sub>cont</sub>	6.7	3.3	6.7	13.3	3.3	6.7	Adc continuous
Aux HV	+20 to +HV Vdc @ 500 mAdc maximum						

PWM OUTPUTS	
Type	3-phase MOSFET inverter, 15 kHz center-weighted PWM, space-vector modulation
PWM ripple frequency	30 kHz

DIGITAL CONTROL	
Digital Control Loops	Current, velocity, position. 100% digital loop control
Sampling rate (time)	Current loop: 15 kHz (66.7 μs) Velocity, position loops: 3 kHz (333 μs)
Commutation	Sinusoidal, field-oriented control for brushless motors
Modulation	Center-weighted PWM with space-vector modulation
Bandwidths	Current loop: 2.5 kHz typical, bandwidth will vary with tuning & load inductance
HV Compensation	Changes in bus voltage do not affect bandwidth
Minimum load inductance	200 μH line-line

COMMAND INPUTS		
CANopen communications	Profile Position, Profile Velocity, & Profile Torque, Interpolated Position (PVT), Homing	
Digital position reference	Step/Direction, CW/CCW	Stepper commands (2 MHz maximum rate)
Digital torque & velocity reference	Quad A/B Encoder	2 M lines/sec, 8 M count/sec (after quadrature)
	PWM, Polarity	PWM = 0~100%, Polarity = 1/0
	PWM	PWM = 50% +/-50%, no polarity signal required
	PWM frequency range	1 kHz minimum, 100 kHz maximum
	PWM minimum pulse width	220 ns
Analog torque, velocity, position	±10 Vdc	Differential, 5kΩ impedance

DIGITAL INPUTS	
Number	12
All inputs	74HC14 Schmitt trigger operating from +5 Vdc with RC filter on input 10 kΩ shunt resistor
Logic levels	Vin-LO < 1.35 Vdc, Vin-HI > 3.65 Vdc
Configuration	Programmable pull-up to +5 Vdc or pull-down to ground in four groups with active-level selection (HI/LO)
Enable [IN1]	Dedicated input for amplifier enable with 330 μs RC filter 0~24 Vdc
GP [IN2,3,4,5,11,12]	General Purpose inputs with 330 μs RC filter (33 μs for IN5), 0~24 Vdc
HS [IN6,7,8,9,10]	High-Speed inputs inputs with 100 ns RC filter, 0~5 Vdc

DIGITAL OUTPUTS	
Number	3
[OUT1], [OUT2], [OUT3]	Current-sinking MOSFET with 1 kΩ pullup to +5 Vdc through diode
Current rating	1 Adc max, +30 Vdc max. Functions programmable External flyback diode required if driving inductive loads

MULTI-MODE ENCODER PORT	
Operation	Programmable as input for secondary (dual) digital encoder or as buffered outputs in quad A/B/X format for digital motor feedback encoder, or emulated encoder outputs from analog sin/cos motor feedback encoder (ServoTube)
Signals	Quad A/B Encoder: A, /A, B, /B, X, /X
Frequency	As input for digital encoder: 5M lines/sec, 20 M count/sec (after quadrature) As buffered outputs for digital motor encoder: 5 M lines/sec, 20 M count/sec (after quadrature) As emulated encoder outputs for sin/cos analog motor encoder: 4.5 M lines/sec, 18 M count/sec (after quadrature)
Input/output	26C32 differential line receiver, or 26C31 differential line driver

RS-232 PORT	
Signals	RxD, TxD, Gnd in 6-position, 4-contact RJ-11 style modular connector.
Mode	Full-duplex, serial communication port for amplifier setup and control, 9,600 to 115,200 Baud
Protocol	ASCII or Binary format
Multi-drop	ASCII interface from single RS-232 port to control multiple amplifiers (Xenus, Accelnet, Stepnet) Amplifier with serial connection acts as master for bi-directional data flow to other amplifiers using CAN connections in daisy-chain from amplifier to amplifier

CAN PORTS	
Signals	CANH, CANL, Gnd in dual 8-position RJ-45 style modular connectors, wired as per CAN Cia DR-303-1, V1.1 CAN interface circuit and +5 Vdc supply are optically isolated from amplifier circuits
Format	CAN V2.0b physical layer for high-speed connections compliant
Data	CANopen Device Profile DSP-402
Address selection	16 position rotary switch on front panel with 3 additional address bits available as digital inputs or programmable to flash memory

## MOTOR CONNECTIONS

Phase U, V, W Hall U, V, W Digital Encoder  Analog Encoder  Signals Frequency Interpolation Hall & encoder power Motemp [IN5]  Brake	PWM outputs to 3-phase ungrounded Wye or delta connected brushless motors, or DC brush motors Digital Hall signals, single-ended Quadrature encoder signals, A, /A, B, /B, X, /X, differential (X or Index signal not required) 5 MHz maximum line frequency (20 M counts/sec) 26LS32 differential line receiver with 121 Ω terminating resistor between complementary inputs Sin/cos, differential line driver outputs, 0.5 Vpeak-peak (1.0 Vpeak-peak differential) centered about 2.5 Vdc typical. Common-mode voltage 0.25 to 3.75 Vdc Sin(+), sin(-), cos(+), cos(-) 230 kHz maximum line (cycle) frequency Programmable: 10 bits/cycle (1024 counts/cycle) +5 Vdc ±2% @ 250 mAdc max, current limited to 750 mAdc @ +1 Vdc if output overloaded Motor overtemperature sensor input. Active level programmable Programmable to disable amplifier when motor over-temperature condition occurs Same input circuit as GP digital inputs (Digital Inputs above) [OUT1,2,3] programmable for motor brake function, external flyback diode required
--	--

## STATUS INDICATORS

Amp Status CAN Status	Bicolor LED, amplifier status indicated by color, and blinking or non-blinking condition Bicolor LED, status of CAN bus indicated by color and blink codes to CAN Indicator Specification 303-3
--------------------------	--

## PROTECTIONS

HV Overvoltage HV Undervoltage Amplifier over temperature Short circuits I <sup>2</sup> T Current limiting Motor over temperature	+HV > HV <sub>max</sub> +HV < +20 Vdc Heat plate > 70°C. Output to output, output to ground, internal PWM bridge faults Programmable: continuous current, peak current, peak time Digital inputs programmable to detect motor temperature switch	Amplifier outputs turn off until +HV < HV <sub>max</sub> (See Input Power for HV <sub>max</sub> ) Amplifier outputs turn off until +HV > +20 Vdc Amplifier outputs turn off
--	---	---

## MECHANICAL & ENVIRONMENTAL

Size Weight Ambient temperature Humidity Contaminants Environment Cooling	6.58 in (167 mm) X 3.89 in (98.8 mm) X 1.17 in (29.7 mm) 0.94 lb (0.43 kg) 0 to +45°C operating, -40 to +85°C storage 0 to 95%, non-condensing Pollution degree 2 IEC68-2: 1990 Heat sink and/or forced air cooling required for continuous power output
---	--

Notes: 1. Digital input & output functions are programmable.

## CME 2™ SOFTWARE

Amplifier setup is fast and easy using CME 2™ software. All of the operations needed to configure the amplifier are accessible through this powerful and intuitive program. Auto-phasing of brushless motor Hall sensors and phase wires eliminates “wire and try”. Connections are made once and CME 2™ does the rest thereafter. Encoder wire swapping to establish the direction of positive motion is eliminated.

Motor data can be saved as .ccm files. Amplifier data is saved as .ccx files that contain all amplifier settings plus motor data. This eases system management as files can be cross-referenced to amplifiers. Once an amplifier configuration has been completed systems can be replicated easily with the same setup and performance.

## RS-232 COMMUNICATIONS

Accelnet is configured via a three-wire, full-duplex RS-232 port that operates from 9600 to 115,200 Baud. CME 2™ provides a graphic user interface (GUI) to set up all of Accelnet features via a computer serial port. Connections to the Accelnet RS-232 port are through J6, an RJ-11 style connector. Signal format is full-duplex, 3-wire using RxD, TxD, and Gnd. The Accelnet Serial Cable Kit (SER-CK) contains a modular cable, and an adapter that connects to a 9-pin, Sub-D serial port connector (COM1, COM2, etc.) on PC's and compatibles.

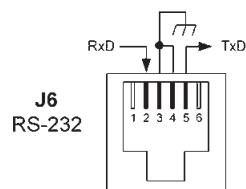

## CANOPEN NETWORKING

Based on the CAN V2.0b physical layer, a robust, two-wire communication bus originally designed for automotive use where low-cost and noise-immunity are essential, CANopen adds support for motion-control devices and command synchronization. The result is a highly effective combination of data-rate and low cost for multi-axis motion control systems. Device synchronization enables multiple axes to coordinate moves as if they were driven from a single control card.

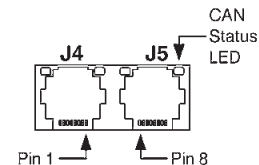

### AMPLIFIER STATE

- Pre-operational
- Operational
- Stopped
- Warning Limit Reached
- Error Control Event
- Sync Error
- Bus-off

### LED ON-OFF CONDITION

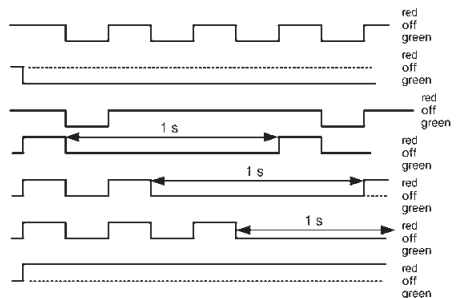

## AMP STATUS LED

A single bi-color LED gives the state of the amplifier by changing color, and either blinking or remaining solid. The possible color and blink combinations are:

- **Green/Solid:** Amplifier OK and enabled. Will run in response to reference inputs or CANopen commands.
- **Green/Slow-Blinking:** Amplifier OK but NOT-enabled. Will run when enabled.
- **Green/Fast-Blinking:** Positive or Negative limit switch active. Amplifier will only move in direction not inhibited by limit switch.
- **Red/Solid:** Transient fault condition. Amplifier will resume operation when fault is removed.
- **Red/Blinking:** Latching fault. Operation will not resume until amp is Reset

Fault conditions:

- Over or under-voltage
- Motor over-temperature
- Phasing error (current position is  $>60^\circ$  electrical from Hall angle)
- Short-circuits from output to output
- Short-circuits from output to ground
- Internal short circuits
- Amplifier over-temperature
- Position-mode following error

Faults are programmable to be either transient or latching

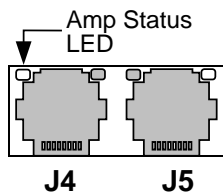

## DIGITAL INPUTS

Accelnet has twelve digital inputs, eleven of which have programmable functions. Input [IN1] is not programmable and is dedicated to the amplifier Enable function. This is done to prevent accidental programming of the input in such a way that the controller could not shut it down.

Two types of RC filters are used: GP (general purpose) and HS (high speed). Input functions such as Step/Direction, CW/CCW, Quad A/B are wired to inputs having the HS filters, and inputs with the GP filters are used for general purpose logic functions, limit switches, and the motor temperature sensor. Programmable functions of the digital inputs include:

- Positive Limit switch
- Negative Limit switch
- Home switch
- Amplifier Reset
- PWM current or velocity commands
- CAN address bits
- Step & Direction, or CW/CCW step motor position commands
- Quad A/B master encoder position commands
- Motor over-temperature

In addition to the active level and function for each programmable input, the input resistors are programmable in four groups to either pull up to +5 Vdc, or down to ground. Inputs pulled up to +5 Vdc work with open-collector NPN drivers that sink current to ground. Grounded inputs with HI active levels interface to devices like PLC's that have PNP outputs that source current into grounded loads. GP inputs can work with 24V sources, HS inputs are limited to 5V maximum.

### GP INPUTS 1,2,3 24 Vdc max

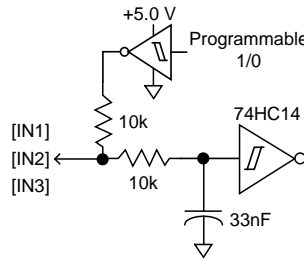

### GP INPUTS 4,5 24 Vdc max

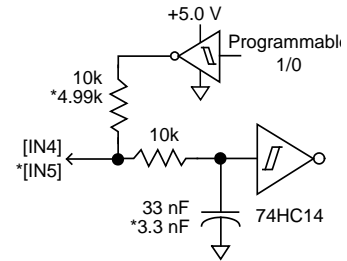

\* [IN5] connects to J2 for motor overtemp switch

### HS INPUTS 6,7,8 5 Vdc max

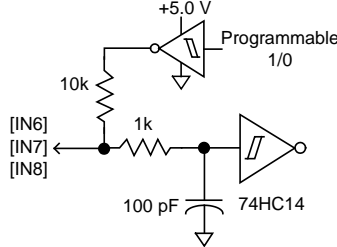

### HS & GP\* INPUTS 9,10,11,12 5 (\*24) Vdc max

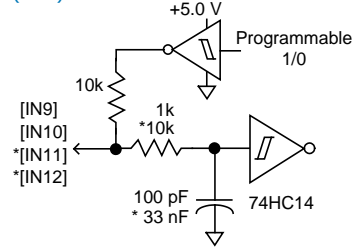

## DIGITAL OUTPUTS

Digital outputs are open-drain MOSFETs with 1 kΩ pull-up resistors to +5 Vdc. These can sink up to 1 Adc from external loads operating from power supplies to +30 Vdc. When driving inductive loads such as a motor brake, an external fly-back diode is required. The diode in the output is for driving PLC inputs that are opto-isolated and connected to +24 Vdc. The diode prevents conduction from +24 Vdc through the 1 kΩ resistor to +5 Vdc in the amplifier. This could turn the input on, giving a false indication of the amplifier output state.

These outputs are programmable to be on or off when active. Typical functions are amplifier fault indication or motor brake operation. Other functions are programmable.

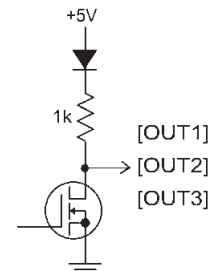

**COMMAND INPUTS IN STAND-ALONE MODE**

The Command inputs are used when the amplifier is taking current, velocity, or position commands from an external controller in stand-alone mode. The command inputs take signals in a variety of formats:

- Current or Velocity Mode
  - PWM/Direction
  - PWM 50%
  - ±10V Analog
- Position Mode
  - CU/CD
  - Step/Direction
  - Master Encoder
  - A/B Quadrature
  - ±10V Analog

For current or velocity control, the PWM/Direction format takes a PWM signal at constant frequency which changes its duty cycle from 0 to 100% to control current or velocity and a DC level at the Direction input to control polarity. The PWM 50% format takes a single PWM signal that produces 0 output at 50% duty cycle, and maximum positive/negative outputs at 0% or 100%. As a protection against wiring faults, the 0% and 100% inputs can be programmed to produce 0 output. When this is done the max/min duty cycle range is >0% and <100%.

Analog signals in ±10V format also function as current, velocity, or position control and D/A converters at their outputs.

Position-control inputs also take signals in popular stepper-motor format or from a digital quadrature encoder. The CU/CD format moves the motor in a positive direction for each pulse received at the count-up input. Negative motion is produced by pulses on the count-down input. The step-direction mode moves the motor an increment of position for every pulse received at the pulse input while the direction of movement is controlled by a DC level on the direction input. Master encoder quadrature signals (A,B) are decoded into four counts per encoder line with the direction derived from the logic-state transitions of the inputs. In position mode the ratio of motor motion per input-count is programmable.

**MULTI-MODE ENCODER PORT**

Depending on amplifier set-up, this port functions either as an input or output for differential encoder signals.

For dual-loop position-mode operation that employs a primary encoder on the motor, and a secondary encoder on the load, the port works as an input receiving the secondary encoder's quad A/B/X signals.

For stand-alone operation with an external motion controller, the signals from the digital encoder on the motor are buffered and made available at the control signal connector for transmission to the controller. This eliminates split-wired motor cables with dual connectors that take the encoder signals to both amplifier and controller.

When used with ServoTube motors, or other motors using analog encoders with sin/cos signal format, the amplifier interpolates the sin/cos signals to a resolution that is programmable. The incremental changes in position are then converted to digital quad A/B/X format for use by the external motion controller.

**CURRENT or VELOCITY MODE REFERENCE INPUTS**

**PWM/Direction Inputs**

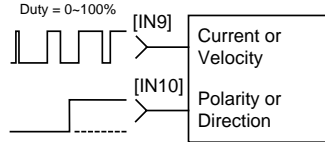

**PWM 50% Input**

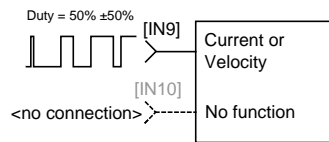

**±10V Analog Input**

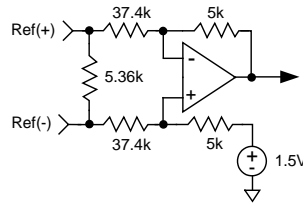

**STEP MOTOR EMULATION INPUTS**

**Count-up/Count-down Inputs**

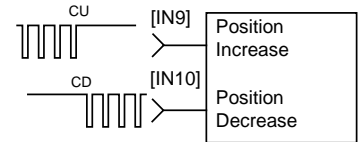

**Pulse/Direction Inputs**

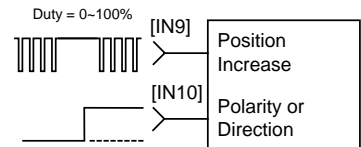

**Master Encoder A/B Inputs**

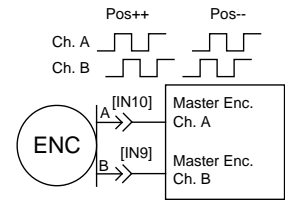

provide an easy interface to controllers with

**FUNCTIONAL DIAGRAM OF ONE CHANNEL**

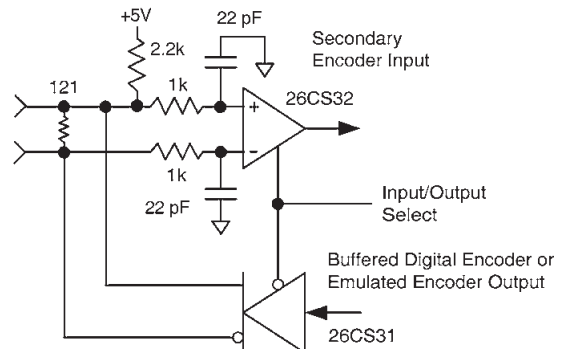

**MOTOR CONNECTIONS**

Motor connections consist of: phases, Halls, encoder, thermal sensor, and brake. The phase connections carry the amplifier output currents that drive the motor to produce motion. The Hall signals are three digital signals that give absolute position feedback within an electrical commutation cycle. The encoder signals give incremental position feedback and are used for velocity and position modes, as well as sinusoidal commutation. A thermal sensor that indicates motor overtemperature is used to shut down the amplifier to protect the motor. A brake can provide a fail-safe way to prevent movement of the motor when the amplifier is shut-down or disabled.

**MOTOR TEMPERATURE SENSOR**

Digital input [IN5] connects to J2 for use with a motor overtemperature switch. The input should be programmed as a pull-up to +5 Vdc if the motor switch is grounded.

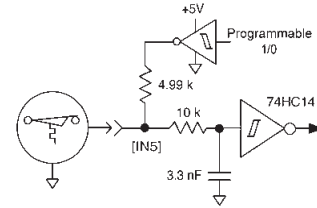

**MOTOR ENCODER**

The input circuit for the motor encoder signals is a differential line-receiver with R-C filtering on the inputs. A 121 Ω resistor is across each input pair to terminate the signal pairs in the cable characteristic impedance. Encoders with differential outputs are required because they are less susceptible to noise that can be picked on single-ended outputs. For best results, encoder cabling should use twisted pair cable with one pair for each of the encoder outputs: A-/A, B-/B, and X-/X. Shielded twisted-pair is even better for noise rejection.

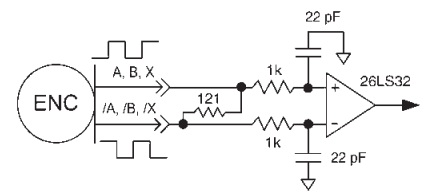

**MOTOR HALL SIGNALS**

Hall signals are single-ended signals that provide absolute feedback within one electrical cycle of the motor. There are three of them (U, V, & W) and they may be sourced by magnetic sensors in the motor, or by encoders that have Hall tracks as part of the encoder disc. They typically operate at much lower frequencies than the motor encoder signals, and in Accelnet they are used for commutation-initialization after startup, and for checking the motor phasing after the amplifier has switched to sinusoidal commutation.

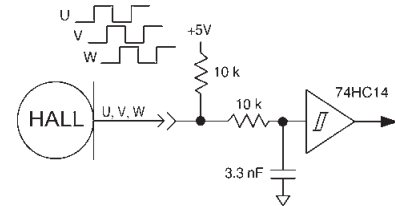

**MOTOR BRAKE**

Digital outputs [OUT1,2,3] can be programmed to power a motor-mounted brake. These brake the motor when they are in an unpowered state and must have power applied to release. This provides a fail-safe function that prevents motor motion if the system is in an unpowered (uncontrolled) state. Because brakes are inductive loads, an external flyback diode must be used to control the coil voltage when power is removed. The timing of the brake is programmable.

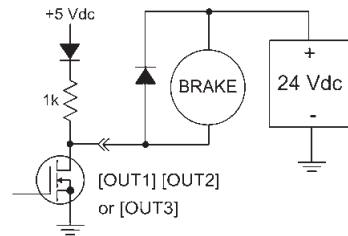

**ANALOG ENCODER SIGNALS**

The Sin and Cos inputs are differential with 121 Ω terminating resistors and accept 1.0 Vp-p signals in the format used by encoders with analog outputs such as Heidenhain, Stegman, and Renishaw, or with ServoTube motors. The resolution is programmable from 4 to 1024 counts/cycle.

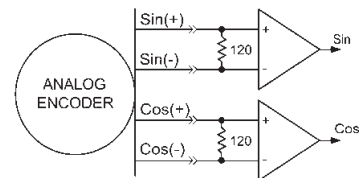

**MOTOR PHASE CONNECTIONS**

The amplifier output is a three-phase PWM inverter that converts the DC buss voltage (+HV) into three sinusoidal voltage waveforms that drive the motor phase-coils. Cable should be sized for the continuous current rating of the amplifier. Motor cabling should use twisted, shielded conductors for CE compliance, and to minimize PWM noise coupling into other circuits. The motor cable shield should connect to motor frame and the amplifier HV ground terminal (J1-4) for best results.

CE = Shielded cables required for CE compliance

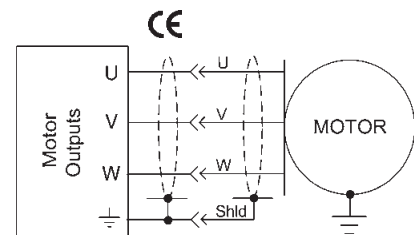

## GROUNDING CONSIDERATIONS

Power and control circuits in *Accelnet* share a common circuit-ground (Gnd on J1-4, and Signal Ground on J2-2, 10, 15, 20, and J3-2, 23). Input logic circuits are referenced to Signal Ground, as are analog Reference inputs, digital outputs, encoder and Hall signals. For this reason, amplifier Gnd terminals should connect to the users' common ground system so that signals between amplifier and controller are at the same common potential, and to minimize noise. The system ground should, in turn, connect to an earthing conductor at some point so that the whole system is referenced to "earth". The CAN ports are optically isolated from the amplifier circuits.

Because current flow through conductors produces voltage-drops across them, it is best to connect the amplifier HV Return to system earth, or circuit-common through the shortest path, and to leave the power-supply floating. In this way, the power supply (-) terminal connects to ground at the amplifier HV Return terminals, but the voltage drops across the cables will not appear at the amplifier ground, but at the power supply negative terminal where they will have less effect.

Motor phase currents are balanced, but currents can flow between the PWM outputs, and the motor cable shield. To minimize the effects of these currents on nearby circuits, the cable shield should connect to Gnd (J1-4).

The amplifier case does not connect to any amplifier circuits. Connections to the case are provided on connectors J2-1, and J3-1. Cables to these connectors should be shielded for CE compliance, and the shields should connect to these terminals. When installed, the amplifier case should connect to the system chassis. This maximizes the shielding effect of the case, and provides a path to ground for noise currents that may occur in the cable shields.

Signals from controller to amplifier are referenced to +5 Vdc, and other power supplies in user equipment. These power supplies should also connect to system ground and earth at some point so that they are at same potential as the amplifier circuits.

The final configuration should embody three current-carrying loops. First, the power supply currents flowing into and out of the amplifier at the +HV and Gnd pins on J1. Second the amplifier outputs driving currents into and out of the motor phases, and motor shield currents circulating between the U, V, and W outputs and Gnd. And, lastly, logic and signal currents connected to the amplifier control inputs and outputs.

For CE compliance and operator safety, the amplifier should be earthed by using external tooth lockwashers under the mounting screws. These will make contact with the aluminum chassis through the anodized finish to connect the chassis to the equipment frame ground.

## POWER SUPPLIES

*Accelnet* operates typically from transformer-isolated, unregulated DC power supplies. These should be sized such that the maximum output voltage under high-line and no-load conditions does not exceed the amplifiers maximum voltage rating. Power supply rating depends on the power delivered to the load by the amplifier. In many cases, the continuous power output of the amplifier is considerably higher than the actual power required by an incremental motion application.

Operation from regulated switching power supplies is possible if a diode is placed between the power supply and amplifier to prevent regenerative energy from reaching the output of the supply. If this is done, there must be external capacitance between the diode and amplifier.

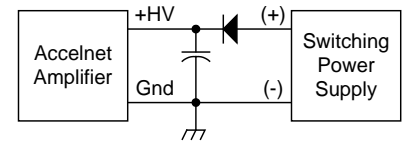

## AUXILIARY HV POWER

*Accelnet* has an input for AUX- HV. This is a voltage that can keep the amplifier communications and feedback circuits active when the PWM output stage has been disabled by removing the main +HV supply. This can occur during EMO (Emergency Off) conditions where the +HV supply must be removed from the amplifier and powered-down to ensure operator safety. The AUX HV input operates from any DC voltage that is within the operating voltage range of the amplifier and powers the DC/DC converter that supplies operating voltages to the amplifier DSP and control circuits.

When the amplifier +HV voltage is greater than the AUX-HV voltage it will power the DC/DC converter. Under these conditions the AUX-HV input will draw no current.

## MOUNTING & COOLING

*Accelnet* has slots for mounting to panels at 0° or 90°. Cooling is by conduction from amplifier heatplate to mounting surface, or by convection to ambient.

A heatsink (optional) is required for the amplifier to deliver the rated continuous output current. Depending on the amplifier mounting and cooling means this may not be required.

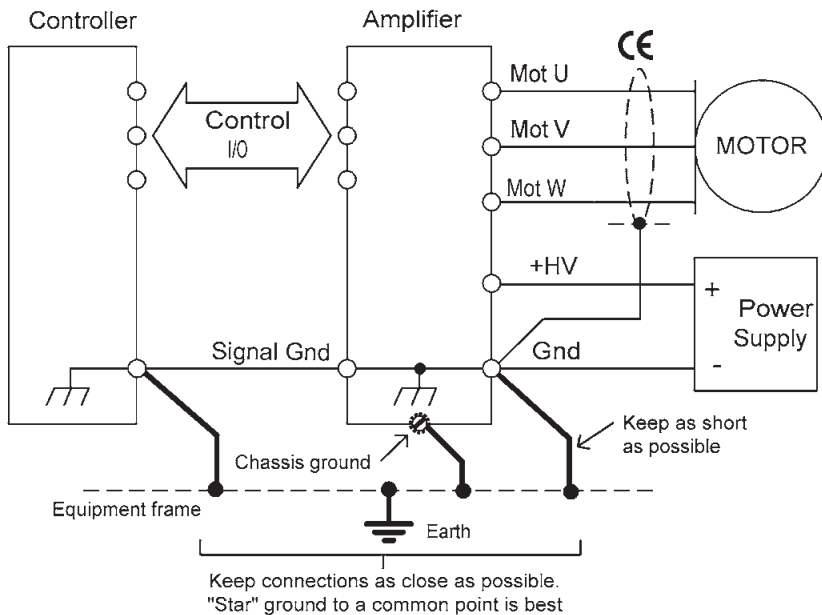

 = Shielded cables required for CE compliance

AMPLIFIER CONNECTIONS

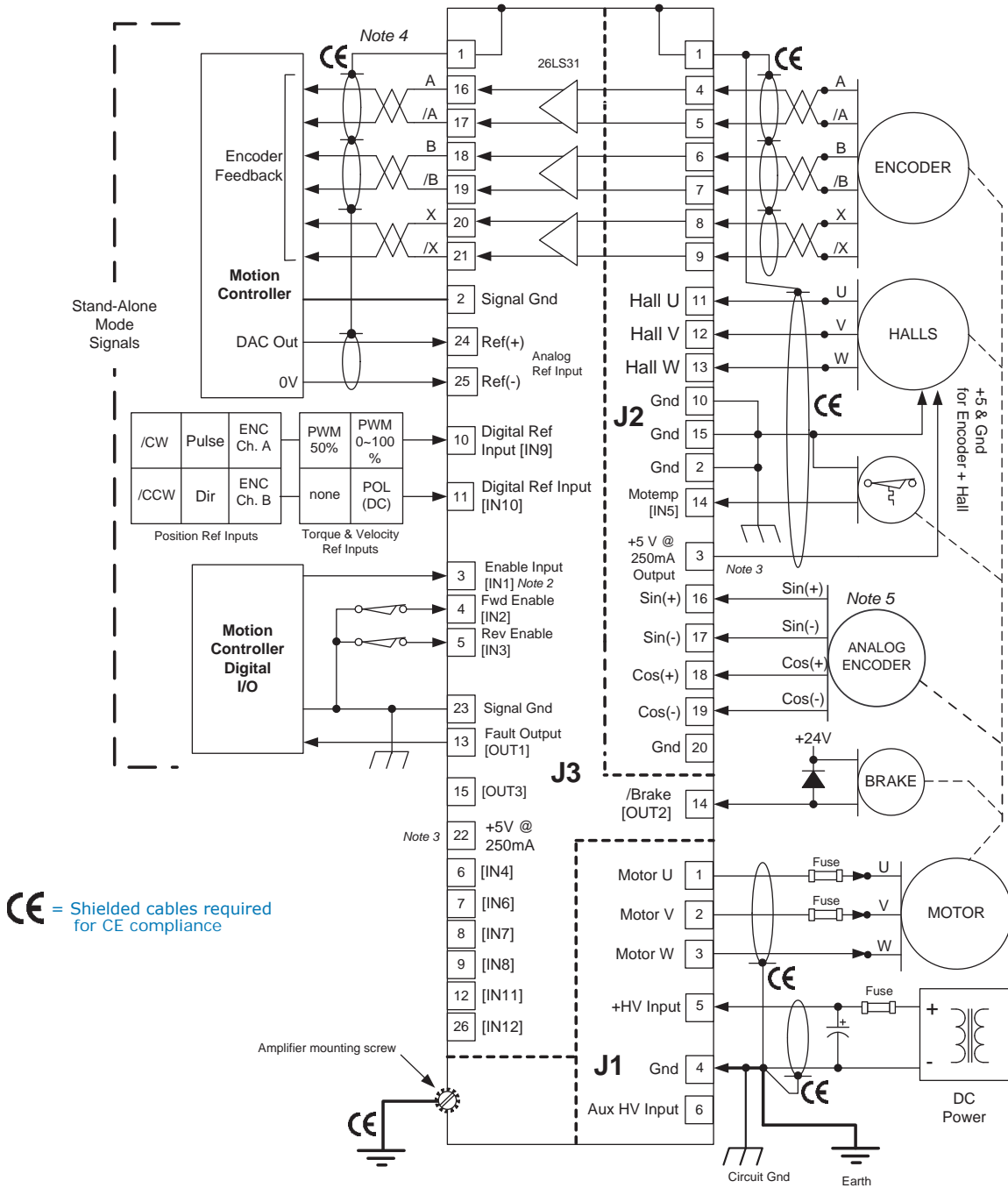

NOTES

- The functions of input signals on J2-14, and J3-4,5,6,7,8,9,10,11,12, and 26 are programmable. Default functions are shown.
- The function of [IN1] on J3-3 is always Amplifier Enable and is not programmable.
- Pins J3-22 and J2-3 connect to the same +5 Vdc @ 250 mAdc power source. Total current drawn from both pins cannot exceed 250 mAdc.
- Multi-mode encoder port (J3-16~21) is shown configured for buffered-output of a digital primary motor encoder.

## CONNECTORS & SIGNALS

J6 Signal	Pin
No connect	6
TxD Output	5
Signal Ground	4
Signal Ground	3
RxD Input	2
No connect	1

### J6: RS-232 PORT

RJ-11 style, male, 6 position  
Cable: 6-conductor modular type

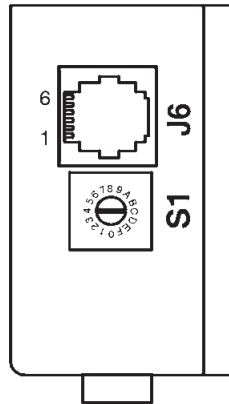

**J4, J5 CABLE CONNECTOR:**  
RJ-45 style, male, 8 position  
Cable: 8-conductor modular type

### J4, J5: CAN BUS

Pin	J4,J5 Signal
1	CAN_H
2	CAN_L
3	CAN_GND
4	No connection
5	Reserved
6	(CAN_SHLD) <sup>1</sup>
7	CAN_GND
8	(CAN_V+) <sup>1</sup>

### NOTES

- These signals interconnect between J4 & J5 but have no internal connections to the amplifier
- CAN circuits in dashed outline are optically isolated from amplifier circuits.

### J3: SIGNAL (CONTROL)

J3 SIGNAL	PIN
Chassis Ground	1
Signal Ground	2
Enable Input [IN1]	3
Programmable Input [IN2]	4
Programmable Input [IN3]	5
Programmable Input [IN4]	6
Programmable Input [IN6]	7
Programmable Input [IN7]	8
Programmable Input [IN8]	9
Programmable Input [IN9]	10
Programmable Input [IN10]	11
Programmable Input [IN11]	12
Output [OUT1]	13

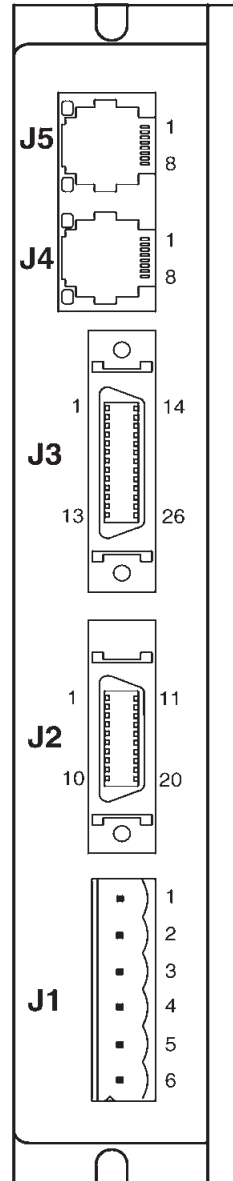

PIN	J3 SIGNAL
14	[OUT2] Output 2
15	[OUT3] Output 3
16	Tri-Mode Encoder A
17	Tri-Mode Encoder /A
18	Tri-Mode Encoder B
19	Tri-Mode Encoder /B
20	Tri-Mode Encoder X
21	Tri-Mode Encoder /X
22	+5 Vdc @ 250 mA
23	Signal ground
24	Analog Ref(+)
25	Analog Ref(-)
26	[IN12] Programmable Input

### J3: SIGNAL (CONTROL)

**J3 CABLE CONNECTOR:**  
Solder Cup, 26 position male, 1.27 mm pitch  
Cable: 26 conductor, shielded  
Standard with Snap locks  
3M: 10126-3000 VE connector  
3M: 10326-52F0-008 backshell  
Rugged with Screw-locks  
Molex: 54306-2619 connector  
Molex: 54331-0261 backshell

*Note: Molded cable assemblies are available for J2 & J3.  
See p. 10 for cable colors.*

J2 SIGNAL	PIN
Chassis Ground	1
Signal Ground	2
+5 Vdc @ 250 mA	3
Encoder A Input	4
Encoder /A Input	5
Encoder B Input	6
Encoder /B Input	7
Encoder X Input	8
Encoder /X Input	9
Signal Ground	10

PIN	J2 SIGNAL
11	Hall U Input
12	Hall V Input
13	Hall W Input
14	[IN5] Motor Temp Sensor
15	Signal Ground
16	Analog Encoder Sin(+)
17	Analog Encoder Sin(-)
18	Analog Encoder Cos(+)
19	Analog Encoder Cos(-)
20	Signal Ground

### J2: FEEDBACK

**J2 CABLE CONNECTOR:**  
Solder Cup, 20 position male, 1.27 mm pitch  
Cable: 20 conductor, shielded  
Standard with Snap locks  
3M: 10120-3000VE connector  
3M: 10320-52F0-008 backshell  
Rugged with Screw-locks  
Molex: 54306-2019 connector  
Molex: 54331-0201 backshell

### J1: MOTOR & POWER

PIN	J1 SIGNAL
1	Motor U Output
2	Motor V Output
3	Motor W Output
4	GND
5	+HV Input
6	Aux HV Input

### J1 CABLE CONNECTOR:

Terminal block, 6 position, 5.08 mm, black  
Beau: 860506  
RIA: 31249106  
Weidmuller: 1526810000  
PCD: ELFP06210  
Weco: 121-A-111/06  
Tyco: 796635-6

## ACCESSORY CABLE CONNECTIONS

### SIGNAL CABLE ( ACP-CC-10)

Cable assembly: CCC p/n 59-00785-000  
Molded connector mates with drive J7 and has flying-lead terminations.

### CONNECTOR (FRONT VIEW)

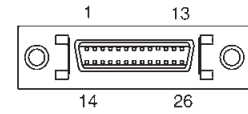

Signal	Pin	Color (Body/Stripe)	Pair	Color (Body/Stripe)	Pin	Signal
Frame Ground	1	Rev A & B: White/Tan Rev C: Brown	1a 8a	White/Violet	14	[OUT2]
Signal Ground	2	Rev A & B: Tan/White Rev C: Orange	1b 8b	Violet/White	15	[OUT3]
Enable [IN1]	3	White/Brown	2a 9a	White/Grey	16	Multi-Encoder A
GP Input [IN2]	4	Brown/White	2b 9b	Gray/White	17	Multi-Encoder /A
GP Input [IN3]	5	White/Pink	3a 10a	Tan/Brown	18	Multi-Encoder B
GP Input [IN4]	6	Pink/White	3b 10b	Brown/Tan	19	Multi-Encoder /B
HS Input [IN6]	7	White/Orange	4a 11a	Tan/Pink	20	Multi-Encoder X
HS Input [IN7]	8	Orange/White	4b 11b	Pink/Tan	21	Multi-Encoder /X
HS Input [IN8]	9	White/Yellow	5a 12a	Tan/Orange	22	+5 Vdc @ 400 mA
HS Input [IN9]	10	Yellow/White	5b 12b	Orange/Tan	23	Signal Ground
HS Input [IN10]	11	White/Green	6a 13a	Tan/Yellow	24	Analog Ref(+)
GP Input [IN11]	12	Green/White	6b 13b	Yellow/Tan	25	Analog Ref(-)
[OUT1]	13	White/Blue	7a 7b	Blue/White	26	[IN12] GP Input

### FEEDBACK CABLE ( ACP-FC-10)

Cable assembly: CCC p/n 59-00786-000  
Molded connector mates with drive J7 and has flying-lead terminations.

### CONNECTOR (FRONT VIEW)

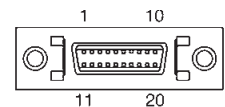

Signal	Pin	Color (Body/Stripe)	Pair	Color (Body/Stripe)	Pin	Signal
Frame Ground	1	Rev A & B: White/Tan RevC: Brown	1a 1b	Rev A & B: Tan/White Rev C: Orange	11	Digital Hall U
Signal Ground	2	White/Brown	2a 7a	White/Blue	12	Digital Hall V
+5 Vdc @ 400 mA	3	Brown/White	2b 7b	Blue/White	13	Digital Hall W
Encoder Input A	4	White/Pink	3a 8a	White/Violet	14	[IN5] Temp Sensor
Encoder Input /A	5	Pink/White	3b 8b	Violet/White	15	Signal Ground
Encoder Input B	6	White/Orange	4a 9a	White/Gray	16	Analog Sin(+)
Encoder Input /B	7	Orange/White	4b 9b	Gray/White	17	Analog Sin(-)
Encoder Input X	8	White/Yellow	5a 10a	Tan/Brown	18	Analog Cos(+)
Encoder Input /X	9	Yellow/White	5b 10b	Brown/Tan	19	Analog Cos(-)
Signal Ground	10	White/Green	6a 6b	Green/White	20	Signal Ground

Note: Cable shields connect to connector shells and not to conductors. The shells of drive J7 & J8 are connected to the earth ground terminal on power connector J1 and to the drive chassis. When the cables above are connected to the drive a continuous path from cable shield to earth is established for shielding and CE compliance.

## DIMENSIONS

### NOTES

1. Dimensions shown in inches (mm).

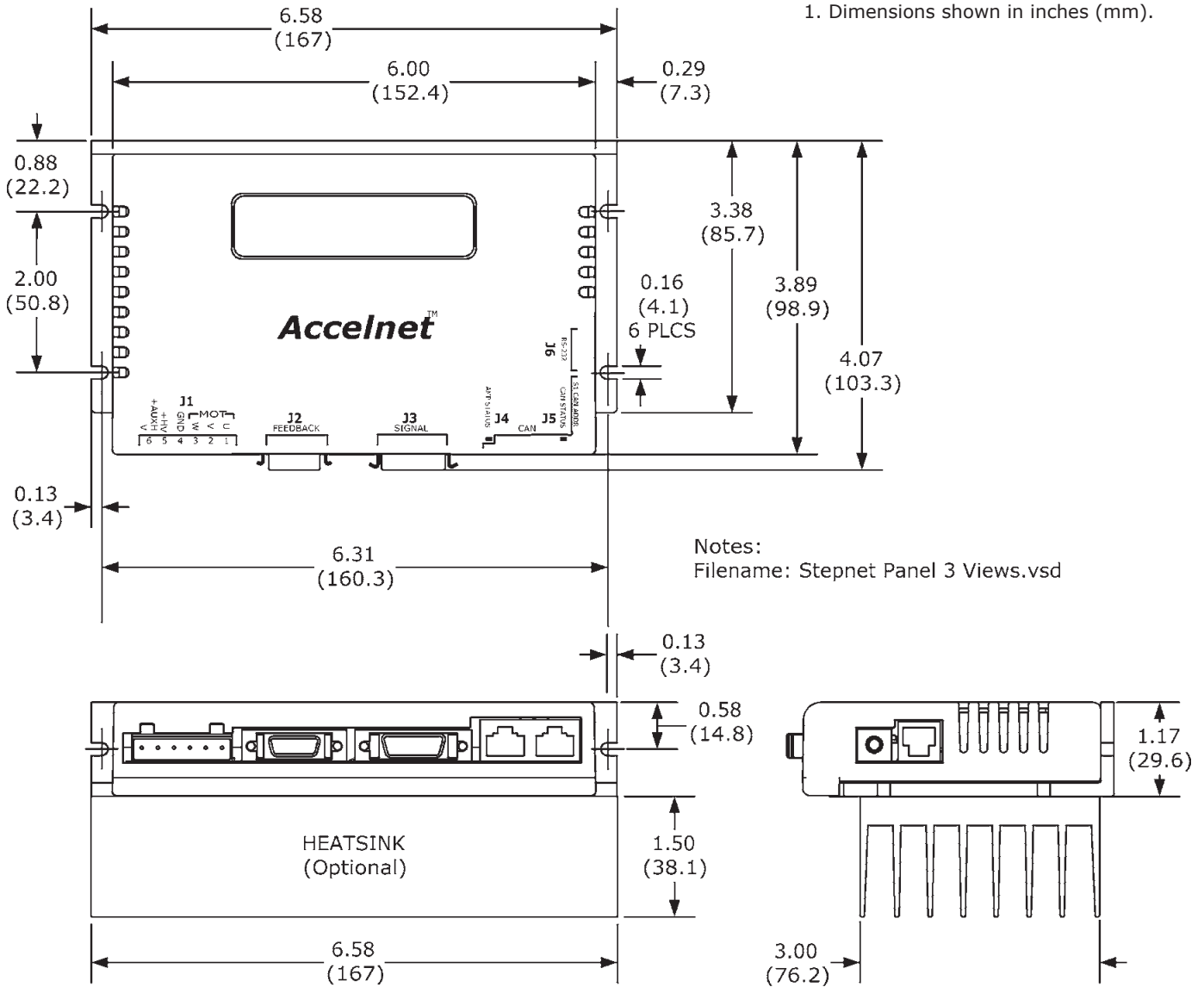

### Weights:

Amplifier: 0.94 lb (0.43 kg)  
Heatsink: 1.0 lb (0.45 kg)

## CANOPEN CONFIGURATION

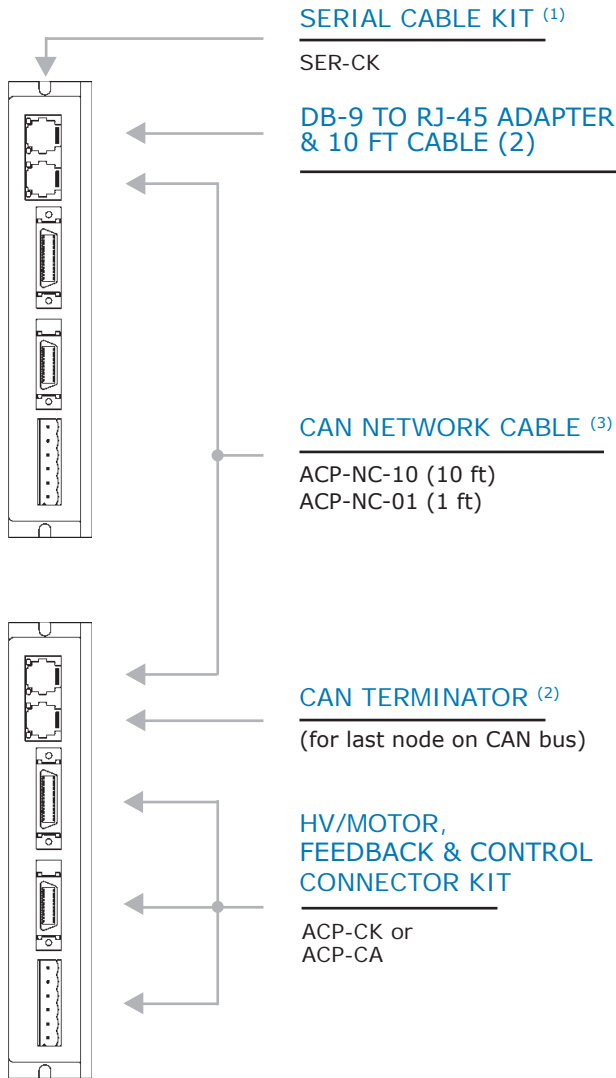

Multiple amplifiers are connected as nodes on a CAN bus

Individual amplifiers are configured using an RS-232 connection and CME 2™ software

**Notes:**

1. Only one SER-CK is needed per installation
2. Included in CANopen Network Kit ACP-NK
3. Order one cable (1 or 10 ft) for each additional amplifier



**POWER SUPPLY**  
Mains-isolated DC  
Required for all systems  
User-supplied



**HEATSINK**  
(Optional)

PART NUMBER	DESCRIPTION
ACP-055-18	Accelnet Servoamplifier, 55 Vdc, 6/18 A
ACP-090-09	Accelnet Servoamplifier, 90 Vdc 3/9 A
ACP-090-18	Accelnet Servoamplifier, 90 Vdc, 6/18 A
ACP-090-36	Accelnet Servoamplifier, 90 Vdc, 12/36 A
ACP-180-09	Accelnet Servoamplifier, 180 Vdc, 3/9 A
ACP-180-18	Accelnet Servoamplifier, 180 Vdc, 6/18 A
ACP-CK	Connector Kit for Accelnet (P1 plug, and plugs with soldercups & backshells for P2 & P3)
ACP-CA	Connector Kit for Accelnet (P1 plug, and molded 10 ft cable with flying leads for P2 & P3)
ACP-NK	CAN Network Kit (Sub-D 9F to RJ-45 adapter, 10 ft. modular cable, and CAN terminator)
ACP-NC-10	CAN network cable, 10 ft (3 m)
ACP-NC-01	CAN network cable, 1 ft (0.3 m)
CME 2	CD with CME 2 Configuration Software
SER-CK	RS-232 Cable Kit
ACP-HK	Heatsink (optional)

## STAND-ALONE CONFIGURATION

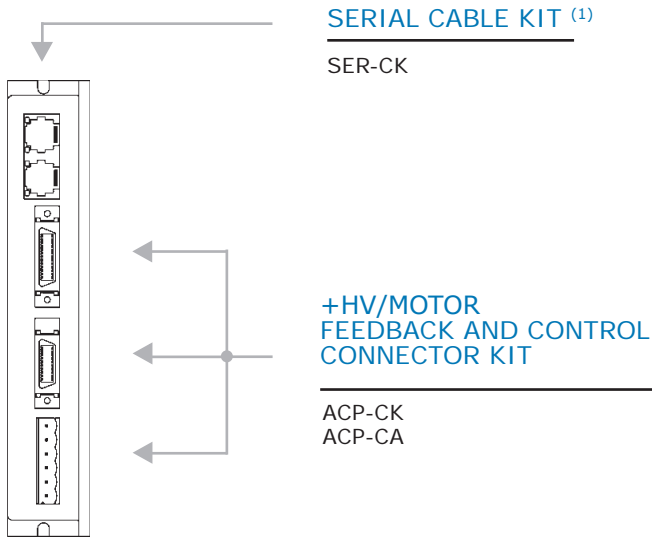

Current or Velocity Mode Signals:  
 PWM & Polarity  
 PWM 50%  
 ±10V Analog

Position-mode Signals:  
 Step/Direction  
 CW/CCW  
 ±10V Analog

Electronic Gearing Signals:  
 A/B Quadrature encoder

CME 2™ is used for setup and configuration.



### POWER SUPPLY

**+HV**  
 Mains-isolated DC  
 Required for all systems  
 User-supplied

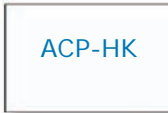

### HEATSINK

(Optional)

PART NUMBER	DESCRIPTION
ACP-055-18	Accelnet Servoamplifier, 55 Vdc, 6/18 A
ACP-090-09	Accelnet Servoamplifier, 90 Vdc 3/9 A
ACP-090-18	Accelnet Servoamplifier, 90 Vdc, 6/18 A
ACP-090-36	Accelnet Servoamplifier, 90 Vdc, 12/36 A
ACP-180-09	Accelnet Servoamplifier, 180 Vdc, 3/9 A
ACP-180-18	Accelnet Servoamplifier, 180 Vdc, 6/18 A
ACP-CK	Connector Kit for Accelnet (P1 plug, and plugs with soldercups & backshells for P2 & P3)
ACP-CA	Connector Kit for Accelnet (P1 plug, and molded 10 ft cable with flying leads for P2 & P3)
CME 2	CD with CME 2 Configuration Software
SER-CK	RS-232 Cable Kit
ACP-HK	Heatsink (optional)

**POWER DISSIPATION**

The charts on this page show the amplifier internal power dissipation for the *Accelnet* models under differing power supply and output current conditions. Amplifier output current is calculated from the motion profile, motor, and load conditions. The values on the chart represent the RMS (root-mean-square) current that the amplifier would provide during operation. The +HV values are for the average DC voltage of the amplifier power supply.

When +HV and amplifier output current are known, the amplifier power dissipation can be found from the chart. Once this is done use the data on the facing page to find amplifier thermal resistance. From this calculate the maximum ambient operating temperature. If this result is lower than the known maximum ambient temperature then a mounting with a lower thermal resistance must be used.

When the amplifier is disabled the power dissipation is shown on the chart as "Off". Note that this is a different value than that of an amplifier that is "On" but outputting 0 A current.

**55 & 90 VDC MODELS**

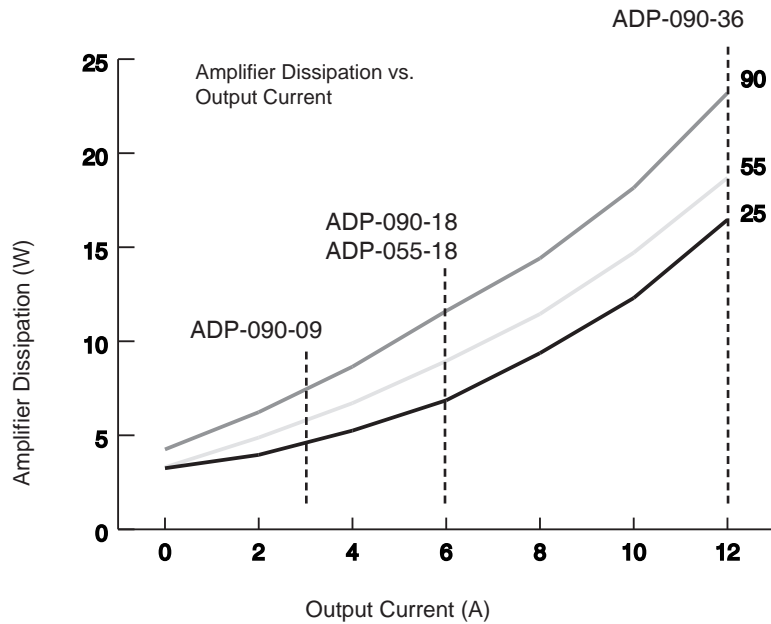

**180 VDC MODELS**

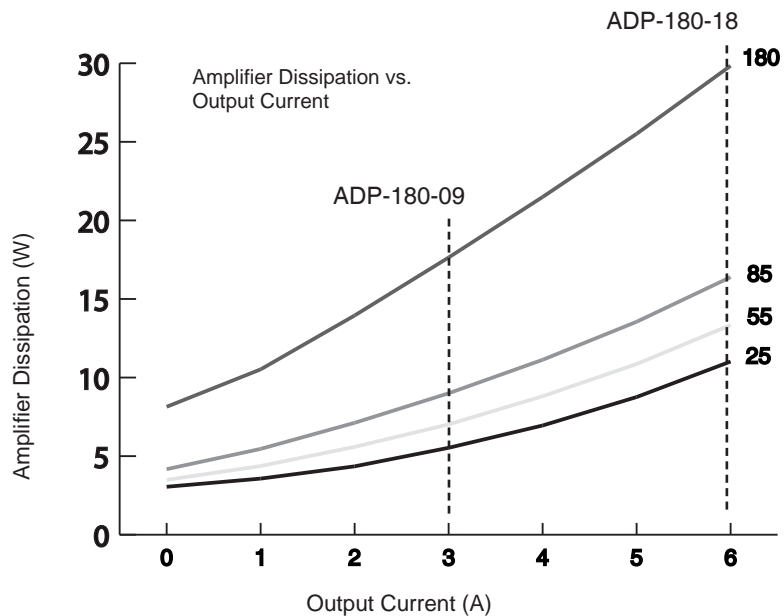

## MOUNTING

Thermal data for convection-cooling with a heatsink assumes a vertical mounting of the amplifier on a thermally conducting surface. Heatsink fins run parallel to the long axis of the amplifier. When fan-cooling is used vertical mounting is not necessary to guarantee thermal performance of the heatsink.

## THERMAL RESISTANCE

Thermal resistance is a measure of the temperature rise of the amplifier heatplate due to power dissipation in the amplifier. It is expressed in units of °C/W where the degrees are the temperature rise *above ambient*.

E.g., an amplifier dissipating 16 W mounted with no heatsink or fan would see a temperature rise of 46 °C above ambient based on the thermal resistance of 2.9 °C/W. Using the amplifier maximum heatplate temperature of 70 °C and subtracting 46 °C from that would give 24 °C as the maximum ambient temperature the amplifier in which the amplifier could operate before going into thermal shutdown. To operate at higher ambient temperatures a heatsink or forced-air would be required.

### END VIEWS VERTICAL MOUNTING

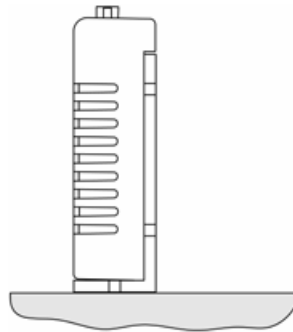

<b>NO HEATSINK, NO FAN</b>	<b>°C/W</b>
CONVECTION	2.9

### TOP VIEW VERTICAL MOUNTING WITH FAN

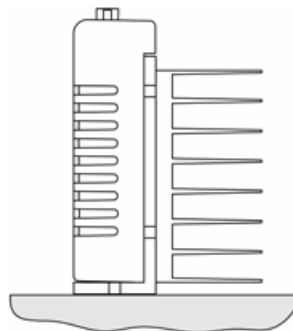
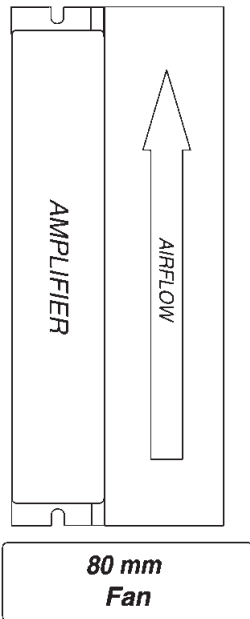

<b>HEATSINK, NO FAN</b>	<b>°C/W</b>
CONVECTION	1.7

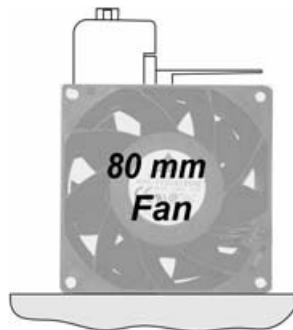

<b>HEATSINK + FAN</b>	<b>°C/W</b>
FORCED-AIR, 300 LFM	0.6

## MASTER ORDERING GUIDE

PART NUMBER	DESCRIPTION
ACP-055-18	Accelnet Servoamplifier, 55 Vdc, 6/18 A
ACP-090-09	Accelnet Servoamplifier, 90 Vdc 3/9 A
ACP-090-18	Accelnet Servoamplifier, 90 Vdc, 6/18 A
ACP-090-36	Accelnet Servoamplifier, 90 Vdc, 12/36 A
ACP-180-09	Accelnet Servoamplifier, 180 Vdc, 3/9 A
ACP-180-18	Accelnet Servoamplifier, 180 Vdc, 6/18 A
ACP-CK	Connector Kit for Accelnet (P1 plug, and plugs with soldercups & backshells for P2 & P3)
ACP-CA	Connector Kit for Accelnet (P1 plug, and molded 10 ft cable with flying leads for P2 & P3)
ACP-NK	CAN Network Kit (Sub-D 9F to RJ-45 adapter, 10 ft. modular cable, and CAN terminator)
ACP-NC-10	CAN network cable, 10 ft (3 m)
ACP-NC-01	CAN network cable, 1 ft (0.3 m)
ACP-CC-10	Molded control cable (to J3), 10 ft, flying leads
ACP-FC-10	Molded feedback cable (to J2), 10 ft, flying leads
ACP-CV	CAN adapter (Sub-D 9F to RJ-45)
ACP-NT	CAN network terminator (121Ω in RJ-45 plug)
SER-CK	RS-232 Cable Kit
CME 2	CD with CME 2 Configuration Software
ACP-HK	Heatsink (optional)

## ORDERING INSTRUCTIONS

Example: Order 1 ACP-090-18 amplifier with heat-sink installed at factory and associated components:

Qty	Item	Remarks
1	ACP-090-18-H	Accelnet servoamplifier
1	ACP-CK	Connector Kit
1	SER-CK	Serial Cable Kit
1	CME2	CME 2™ CD

## DC POWER SUPPLIES TO USE



Up to six Accelnet amplifiers can mount to a PST power supply. All models shown are switch-selectable to operate from 115 or 230 Vac mains.

## ADD A CAN BUS INTERFACE TO YOUR COMPUTER:

Copley's CAN-PCI-02 provides two fully-isolated CAN channels in a PCI-card form-factor and works with the XSJ-NK connector kit.



Amplifier	Power Supply	Vdc	Watts
ACP-055-18	PST-040-13-DP-E	40	520
ACP-090-09	PST-070-08-DP-E	70	525
ACP-090-18			
ACP-090-36			
ACP-180-09	PST-140-04-DP-E	140	490
ACP-180-18			

Note: the -E option is for an extender plate that mounts to the PST power supply and is required for mounting Accelnet Panel amplifiers.

## NEW FEATURES

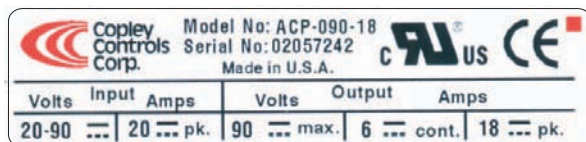

Accelnet Panel models manufactured after February, 2006 have enhanced features and can be identified by the red square on the label. The new features are:

- ±10V analog input for current, velocity, position mode
- Multi-mode encoder port
  - Emulated encoder outputs from ServoTube motors
  - Buffered digital encoder outputs
  - Secondary encoder input